



education

Department of
Education
FREE STATE PROVINCE

PHYSICAL SCIENCES PAPER 2 (CHEMISTRY)

GRADE 12

TERMS & DEFINITIONS, QUESTIONS & ANSWERS PER TOPIC

2019

CONTENTS

HOW TO USE THIS DOCUMENT	2
TERMS AND DEFINITIONS	3
QUESTIONS	10
ORGANIC MOLECULES: NOMENCLATURE	10
ORGANIC MOLECULES: PHYSICAL PROPERTIES	19
ORGANIC MOLECULES: ORGANIC REACTIONS	26
REACTION RATE AND ENERGY IN CHEMICAL REACTIONS	34
CHEMICAL EQUILIBRIUM	45
ACIDS AND BASES	52
GALVANIC CELLS	59
ELECTROLYTIC CELLS	66
FERTILISERS	71
ANSWERS TO QUESTIONS	78
ORGANIC MOLECULES: NOMENCLATURE	78
ORGANIC MOLECULES: PHYSICAL PROPERTIES	84
ORGANIC MOLECULES: ORGANIC REACTIONS	89
REACTION RATE AND ENERGY IN CHEMICAL REACTIONS	94
CHEMICAL EQUILIBRIUM	102
ACIDS AND BASES	110
GALVANIC CELLS	117
ELECTROLYTIC CELLS	120
FERTILISERS	122
BIBLIOGRAPHY	126

HOW TO USE THIS DOCUMENT

Dear Grade 12 learner

1. This document was compiled as an extra resource to help you to perform well in Physical Sciences.
2. Firstly you must make sure that you study the terms and definitions provided for each topic. Theory always forms part of any test or examination and you should ensure that you obtain full marks for ALL theory questions. Always be prepared to write a test on terms and definitions as soon as a topic is completed in class. Revise terms and definitions of topics already completed frequently so that you know them by the time you are sitting for a test or an examination.
3. Answer all the questions on a certain topic in your homework book as soon as the topic is completed. DO NOT look at the answers before attempting the questions. First try it yourself. Compare your answers with the answers at the back of the document. Mark your work with a pencil and do corrections for your incorrect answers. If you do not know how to answer a question, the answers are there to guide you. Acquaint yourself with the way in which a particular type of question should be answered. Answers supplied are from memoranda used to mark the questions in previous years.
4. Your teacher can, for example, give you two of the questions in this document as homework. The following day he/she will just check whether you answered them and whether you marked your answers. The teacher will only discuss those questions in which you do not understand the answers supplied in the document. Therefore a lot of time will be saved.
5. You are probably thinking about the point behind the answers at the back of the document. It is intended to help you to prepare for your tests and examinations. If you choose to copy answers into your homework book without trying them out yourself, you will be the losing party in the end! Not your teacher or anybody else!
6. Your teacher can also decide to give you a test on one of the questions given for homework. If you just copied the answers without any understanding, surely he/she will catch you! None of us want to be branded as dishonest, do we?
7. Work through all the questions and answers of a particular topic before you sit for an examination, even if you answered the questions before.
8. Any additional resource is only of help when used correctly. Ensure that you make use of all help provided in the correct way to enable you to be successful. All the best for 2019 and may you perform very well in Physical Sciences.

TERMS AND DEFINITIONS

MATTER AND MATERIALS: ORGANIC MOLECULES	
Addition reaction	A reaction in which a double bond in the starting material is broken and elements are added to it.
Addition polymer	A polymer formed when monomers (usually containing a double bond) combine through an addition reaction.
Addition polymerisation	A reaction in which small molecules join to form very large molecules by adding on double bonds.
Alcohol	An organic compound in which H atoms in an alkane have been substituted with hydroxyl groups (-OH groups). General formula: $C_nH_{2n+1}OH$
Aldehydes	Organic compounds having the general structure RCHO where R = H or alkyl. General formula: RCHO (R = alkyl group)
Alkane	An organic compound containing only C-H and C-C single bonds. General formula: C_nH_{2n+2}
Alkene	A compound of carbon and hydrogen that contains a carbon-carbon double bond. General formula: C_nH_{2n}
Alkyl group	A group formed by removing one H atom from an alkane.
Alkyne	A compound of carbon and hydrogen that contains a carbon-carbon triple bond.
Boiling point	The temperature at which the vapour pressure of a liquid equals atmospheric pressure.
Carbonyl group	Functional group of ketones ($>C=O$)
Carboxyl group	Functional group of carboxylic acids (-COOH)
Carboxylic acid	An organic compound containing a carboxyl group (-COOH group). General formula: $C_nH_{2n+1}COOH$ (or RCOOH)
Chain isomers	Compounds with the same molecular formula, but different types of chains.
Condensation polymer	A polymer formed by two monomers with different functional groups that are linked together in a condensation reaction in which a small molecule, usually water, is lost.
Condensation polymerisation	Molecules of two monomers with different functional groups undergo condensation reactions with the loss of small molecules, usually water
Condensed structural formula	A formula that shows the way in which atoms are bonded together in the molecule, but DOES NOT SHOW ALL bond lines.
Cracking	The chemical process in which longer chain hydrocarbon molecules are broken down to shorter more useful molecules.
Dehydration	Elimination of water from a compound usually such as an alcohol.
Dehydrohalogenation	The elimination of hydrogen and a halogen from a haloalkane.
Dipole-dipole force	Intermolecular forces found between polar molecules i.e. molecules in which there is an uneven distribution of charge so that the molecule has a positive and a negative side.
Elimination reaction	A reaction in which elements of the starting material are "lost" and a double bond is formed.
Esterification	The preparation of an ester from the reaction of a carboxylic acid with an alcohol.
Functional group	A bond or an atom or a group of atoms that determine(s) the physical and chemical properties of a group of organic compounds.
Functional isomers	Compounds with the same molecular formula, but different functional groups.
Haloalkane (Alkyl halide)	An organic compound in which one or more H atoms in an alkane have been replaced with halogen atoms. General formula: $C_nH_{2n+1}X$ (X = F, Cl, Br or I)
Halogenation	The reaction of a halogen (Br_2 , Cl_2) with a compound.

Homologous series	A series of organic compounds that can be described by the same general formula and that have the same functional group. OR A series of organic compounds in which one member differs from the next with a CH ₂ group.
Hydration	The addition of water to a compound.
Hydrocarbon	Organic compounds that consist of hydrogen and carbon only.
Hydrogenation	The addition of hydrogen to an alkene
Hydrogen bond	A strong intermolecular force found between molecules in which an H atom is covalently bonded to wither an N, O or F atom.
Hydrohalogenation	The addition of a hydrogen halide to an alkene.
Hydrolysis	The reaction of a compound with water.
Intermolecular force	Forces between molecules that determine physical properties of compounds.
IUPAC name	A chemical nomenclature (set of rules) created and developed by the International Union of Pure and Applied Chemistry (IUPAC) to generate systematic names for chemical compounds.
London force	A weak intermolecular force between non-polar molecules.
Macromolecule	A molecule that consists of a large number of atoms.
Melting point	The temperature at which the solid and liquid phases of a substance are at equilibrium.
Molecular formula	A chemical formula that indicates the type of atoms and the correct number of each in a molecule, e.g. CH ₄ .
Monomer	Small organic molecules that can be covalently bonded to each other in a repeating pattern.
Organic chemistry	Chemistry of carbon compounds.
Polymer	A large molecule composed of smaller monomer units covalently bonded to each other in a repeating pattern
Polymerisation	A chemical reaction in which monomer molecules join to form a polymer
Positional isomer	Compounds with the same molecular formula, but different positions of the side chain, substituents or functional groups on the parent chain.
Primary alcohol	The C atom bonded to the hydroxyl group is bonded to ONE other C atom. Example: $\begin{array}{c} \text{H} \quad \quad \text{H} \\ \quad \quad \\ \text{H}-\text{C}-\text{C}-\text{O}-\text{H} \\ \quad \quad \\ \text{H} \quad \quad \text{H} \end{array}$
Primary haloalkane	The C atom bonded to the halogen is bonded to ONE other C atom. Example: $\begin{array}{c} \text{H} \quad \quad \text{H} \\ \quad \quad \\ \text{H}-\text{C}-\text{C}-\text{Br} \\ \quad \quad \\ \text{H} \quad \quad \text{H} \end{array}$
Saturated compounds	Compounds in which there are no multiple bonds between C atoms in their hydrocarbon chains. OR Compounds with only single bonds between C atoms in their hydrocarbon chains.
Secondary alcohol	The C atom bonded to hydroxyl group is bonded to TWO other C atoms. Example: $\begin{array}{c} \text{H} \quad \quad \text{H} \\ \quad \quad \\ \text{H}-\text{C}-\text{C}-\text{O}-\text{H} \\ \quad \quad \\ \text{H} \quad \quad \text{H}-\text{C}-\text{H} \\ \quad \quad \quad \\ \quad \quad \quad \text{H} \end{array}$

Secondary haloalkane	The C atom bonded to the halogen is bonded to ONE other C atom. Example: $\begin{array}{c} \text{H} \quad \text{H} \\ \quad \\ \text{H}-\text{C}-\text{C}-\text{Br} \\ \quad \\ \text{H} \quad \text{H}-\text{C}-\text{H} \\ \\ \text{H} \end{array}$
Structural formula	A structural formula of a compound shows which atoms are attached to which within the molecule. Atoms are represented by their chemical symbols and lines are used to represent ALL the bonds that hold the atoms together.
Structural isomer	Organic molecules with the same molecular formula, but different structural formulae.
Substituent (branch)	A group or branch attached to the longest continuous chain of C atoms in an organic compound.
Substitution reaction	A reaction in which an atom or a group of atoms in a molecule is replaced by another atom or group of atoms.
Tertiary alcohol	The C atom bonded to the hydroxyl group is bonded to THREE other C atoms. Example: $\begin{array}{c} \text{H} \\ \\ \text{H}-\text{C}-\text{H} \\ \\ \text{H}-\text{C}-\text{C}-\text{O}-\text{H} \\ \quad \\ \text{H} \quad \text{H}-\text{C}-\text{H} \\ \\ \text{H} \end{array}$
Tertiary haloalkane	The C atom bonded to the halogen is bonded to THREE other C atoms. Example: $\begin{array}{c} \text{H} \\ \\ \text{H}-\text{C}-\text{H} \\ \\ \text{H}-\text{C}-\text{C}-\text{Br} \\ \quad \\ \text{H} \quad \text{H}-\text{C}-\text{H} \\ \\ \text{H} \end{array}$
Unsaturated compounds	Compounds in which there are multiple bonds (double or triple bonds) between C atoms in their hydrocarbon chains.
Van der Waals forces	A combined name used for the different types of intermolecular forces.
Vapour pressure	The pressure exerted by a vapour at equilibrium with its liquid in a closed system.

CHEMICAL CHANGE: QUANTITATIVE ASPECTS OF CHEMICAL CHANGE

Mole	One mole of a substance is the amount of substance having the same number of particles as there are atoms in 12 g carbon-12.
Molar gas volume at STP	The volume of one mole of a gas. (1 mole of any gas occupies 22,4 dm ³ at 0 °C (273 K) and 1 atmosphere (101,3 kPa).
Molar mass	The mass of one mole of a substance. Symbol: M Unit: g·mol ⁻¹
Avogadro's Law	Under the same conditions of temperature and pressure, the same number of moles of all gases occupy the same volume.

Concentration	The amount of solute per litre/cubic decimeter of solution. In symbols: $c = \frac{n}{V}$ Unit: mol·dm ⁻³
Empirical formula	The simplest positive integer ratio of atoms present in a compound.
Percentage yield	Yield is the amount of product obtained from a reaction. percentage yield = $\frac{\text{actual mass obtained}}{\text{calculated mass}} \times 100$
Percentage purity	percentage purity = $\frac{\text{mass of pure chemical}}{\text{total mass of sample}} \times 100$
Percentage composition	The percentage of each of the components in a substance. Percentage of component = $\frac{\text{mass contributed by component}}{\text{mass of all components}} \times 100$
Limiting reagents	The substance that is totally consumed when the chemical reaction is complete.

CHEMICAL CHANGE: ENERGY AND CHANGE

Heat of reaction (ΔH)	The energy absorbed or released in a chemical reaction.
Exothermic reactions	Reactions that release energy. ($\Delta H < 0$)
Endothermic reactions	Reactions that absorb energy. ($\Delta H > 0$)
Activation energy	The minimum energy needed for a reaction to take place.
Activated complex	The unstable transition state from reactants to products.

CHEMICAL CHANGE: RATE OF REACTION

Reaction rate	The change in concentration of reactants or products per unit time. Rate = $\frac{\Delta C}{\Delta t}$ Unit: mol·dm ⁻³ ·s ⁻¹
Collision theory	A model that explains reaction rate as the result of particles colliding with a certain minimum energy.
Catalyst	A substance that increases the rate of a chemical reaction without itself undergoing a permanent change. (A catalyst increases the rate of a reaction by providing an alternative path of lower activation energy. It therefore decreases the net/total activation energy.)
Factors that affect reaction rate	Nature of reacting substances, surface area, concentration (pressure for gases), temperature and the presence of a catalyst.

CHEMICAL CHANGE: CHEMICAL EQUILIBRIUM

Open system	A system which continuously interacts with the environment – it exchanges matter and energy with its environment.
Closed system	A system that only exchanges energy with its surroundings, but it does not exchange matter with its surroundings.
Reversible reaction	A reaction is reversible when products can be converted back to reactants.
Chemical equilibrium	Dynamic equilibrium when the rate of the forward reaction equals the rate of the reverse reaction.
Factors that influence the equilibrium position	Pressure (gases only), concentration and temperature.
Le Chatelier's principle	When the equilibrium in a closed system is disturbed, the system will re-instate a new equilibrium by favouring the reaction that will oppose the disturbance.

CHEMICAL CHANGE: ACIDS AND BASES	
Acid-base indicator	A dye used to distinguish between acidic and basic solutions by means of the colour changes it undergoes in these solutions.
Amphiprotic substance/ampholyte	A substance that can act as either an acid or a base.
Arrhenius theory	An acid is a substance that produces hydrogen ions (H^+)/ hydronium ions (H_3O^+) when it dissolves in water. A base is a substance that produces hydroxide ions (OH^-) when it dissolves in water.
Auto-ionisation of water	A reaction in which water reacts with itself to form ions (hydronium ions and hydroxide ions).
Concentrated acids/bases	Contain a large amount (number of moles) of acid/base in proportion to the volume of water.
Conjugate acid-base pair	A pair of compounds or ions that differ by the presence of one H^+ ion. Example: CO_3^{2-} and HCO_3^- OR HCl and Cl^-
Conjugate acid and base	A conjugate acid has one H^+ ion more than its conjugate base. Example: HCO_3^- is the conjugate acid of base CO_3^{2-} . CO_3^{2-} is the conjugate base of acid HCO_3^- .
Dilute acids/bases	Contain a small amount (number of moles) of acid/base in proportion to the volume of water.
Diprotic acid	An acid that can donate two protons. Example: H_2SO_4
Dissociation	The process in which ionic compounds split into ions.
Endpoint	The point in a titration where the indicator changes colour.
Equivalence point	The point in a reaction where equivalent amounts of acid and base have reacted completely.
Hydrolysis	The reaction of a salt with water. OR The reaction of an ion with water to produce the conjugate acid and a hydroxide ion or the conjugate base and a hydronium ion.
Ionisation	The process in which ions are formed during a chemical reaction.
Ion product of water	The product of the ions formed during auto-ionisation of water i.e. $[H_3O^+][OH^-]$ at 25 °C.
Ionisation constant of water (K_w)	The equilibrium value of the ion product $[H_3O^+][OH^-]$ at 25 °C.
K_a value	Ionisation constant for an acid.
K_b value	Dissociation or ionisation constant for a base.
Lowry-Brønsted theory	An acid is a proton (H^+ ion) donor. A base is a proton (H^+ ion) acceptor.
Monoprotic acid	An acid that can donate one proton. Example: HCl
Neutralisation	The reaction of an acid with a base to form a salt (ionic compound) and water.
pH	The negative of the logarithm of the hydronium ion concentration in $mol \cdot dm^{-3}$. In symbols: $pH = -\log[H_3O^+]$ Unit: None
pH scale	A scale from 0 – 14 used as a measure of the acidity and basicity of solutions where $pH = 7$ is neutral, $pH > 7$ is basic and $pH < 7$ is acidic.
Salt	The ionic compound that is the product of a neutralisation reaction.
Standard solution	A solution of precisely known concentration.
Strong bases	Dissociate COMPLETELY in water to form a high concentration of OH^- ions. Examples: sodium hydroxide ($NaOH$) and potassium hydroxide (KOH)
Strong acids	Ionise COMPLETELY in water to form a high concentration of H_3O^+ ions. Examples: hydrochloric acid (HCl), sulphuric acid (H_2SO_4) and nitric acid (HNO_3)

Titration	The procedure for determining the amount of acid (or base) in a solution by determining the volume of base (or acid) of known concentration that will completely react with it.
Weak acids	Ionise INCOMPLETELY in water to form a low concentration of H_3O^+ ions. Examples: ethanoic acid (CH_3COOH) and oxalic acid ($(\text{COOH})_2$)
Weak bases	Dissociate/ionise INCOMPLETELY in water to form a low concentration of OH^- ions. Examples: ammonia (NH_3), sodium hydrogen carbonate (NaHCO_3), sodium carbonate (Na_2CO_3), potassium carbonate (K_2CO_3), calcium carbonate (CaCO_3)

CHEMICAL CHANGE: ELECTROCHEMICAL REACTIONS

Galvanic cell	A cell in which chemical energy is converted into electrical energy. A galvanic (voltaic) cell has self-sustaining electrode reactions.
Electrolytic cell	A cell in which electrical energy is converted into chemical energy.
Redox reaction	A reaction in which an electron transfer takes place.
Oxidation	A loss of electrons./An increase in oxidation number.
Reduction	A gain of electrons./A decrease in oxidation number.
Oxidising agent	A substance that is reduced/gains electrons/whose oxidation number decreases.
Reducing agent	A substance that is oxidised/loses electrons/whose oxidation number increases.
Anode	The electrode where oxidation takes place.
Cathode	The electrode where reduction takes place.
Electrolyte	A solution that conducts electricity through the movement of ions.
Electrolysis	The chemical process in which electrical energy is converted to chemical energy OR the use of electrical energy to produce a chemical change.
Salt bridge	The connection between two half-cells needed to ensure electrical neutrality in the cell. OR: A component used in a galvanic cell to complete the circuit.
Electrodes	An electrical conductor used in a galvanic cell to make contact with a non-metallic part of the circuit e.g. the electrolyte.
Cell notation	A short way to represent a galvanic cell. When writing cell notation, the following convention should be used: <ul style="list-style-type: none"> ○ The $\text{H}_2 \text{H}^+$ half-cell is treated just like any other half-cell. ○ Cell terminals (electrodes) are written on the outside of the cell notation. ○ Active electrodes: reducing agent oxidised species oxidising agent reduced species ○ Inert electrodes (usually Pt or C): Pt reducing agent oxidised species oxidising agent reduced species Pt Example: $\text{Pt} \text{Cl}^-(\text{aq}) \text{Cl}_2(\text{g}) \text{F}_2(\text{g}) \text{F}^-(\text{aq}) \text{Pt}$
Overall cell reaction	The reaction obtained by combining two half-reactions.
Positive value of the standard emf	The reaction is spontaneous under standard conditions.
Standard conditions for a galvanic cell	Temperature: $25\text{ }^\circ\text{C} / 298\text{ K}$ Concentration: $1\text{ mol}\cdot\text{dm}^{-3}$ Pressure (gases only): $101,3\text{ kPa} / 1\text{ atmosphere}$
Standard hydrogen electrode	The reference electrode used to compile the Table of Standard Reduction Potentials. The hydrogen half-cell was given a standard reduction potential of 0 V . Half-cell notation: $\text{Pt} \text{H}_2(\text{g}) \text{H}^+(\text{aq})$ Half-reaction: $2\text{H}^+ + 2\text{e}^- = \text{H}_2$
Electroplating	The covering of an object with a metal by making it the cathode in an electrolytic cell.

Bauxite	The ore from which aluminium is recovered.
Cryolite	An aluminium compound in which aluminium oxide is dissolved to reduce the cost of the extraction of aluminium. Cryolite has a lower melting point than aluminium oxide.
CHEMICAL SYSTEMS: FERTILISERS	
Non-mineral nutrients in plants	C, H and O Obtained from the atmosphere (CO ₂) and rain (H ₂ O)
Primary nutrients for plants	Nitrogen (N), phosphorous (P) and potassium (K) Function: N: essential for plant growth, green leaves P: development of roots, stems and seeds K: resistance against diseases and production of flowers/fruits
NPK fertilisers	Fertilisers containing the three primary nutrients for plants. They contain ammonium nitrate (NH ₄ NO ₃), ammonium phosphate [(NH ₄) ₃ PO ₄] and potassium chloride (KCl).
N : P : K ratio	The ratio of nitrogen, phosphorous and potassium in a fertiliser.
Fractional distillation of liquid air	Industrial preparation of nitrogen from air.
Steam reforming	Preparation of hydrogen from earth gas (methane) Reaction: CH ₄ + H ₂ O → 3H ₂ + CO
Haber process	Industrial preparation of ammonia Reaction: N ₂ + 3H ₂ ⇌ 2NH ₃ Iron (Fe) catalyst
Ostwald process	Industrial preparation of nitric acid Reactions: 1. Catalytic oxidation of ammonia; catalyst: Pt 4NH ₃ + 5O ₂ ⇌ 4NO + 6H ₂ O 2. 2NO + O ₂ → 2NO ₂ 3. 3NO ₂ + H ₂ O → 2HNO ₃ + NO OR 4NO ₂ + 2H ₂ O + O ₂ → 4HNO ₃
Contact process	Industrial preparation of sulphuric acid Reactions: 1. S + O ₂ → SO ₂ 2. 2SO ₂ + O ₂ → 2SO ₃ Contact catalyst: vanadium pentoxide (V ₂ O ₅) 3. SO ₃ + H ₂ SO ₄ → H ₂ S ₂ O ₇ (H ₂ S ₂ O ₇ : fuming sulphuric acid OR pyro sulphuric acid OR oleum) 4. H ₂ S ₂ O ₇ + H ₂ O → 2H ₂ SO ₄
Preparation of ammonium sulphate	ammonia + sulphuric acid → ammonium sulphate 2NH ₃ + H ₂ SO ₄ → (NH ₄) ₂ SO ₄
Preparation of ammonium nitrate	ammonia + nitric acid → ammonium nitrate NH ₃ + HNO ₃ → NH ₄ NO ₃
Eutrophication	The process by which an ecosystem, e.g. a river or dam, becomes enriched with inorganic plant nutrients, especially phosphorus and nitrogen, resulting in excessive plant growth. As plant growth becomes excessive, the amount of dead and decaying plant material increases rapidly.

QUESTION 2

The letters **A** to **F** in the table below represent six organic compounds.

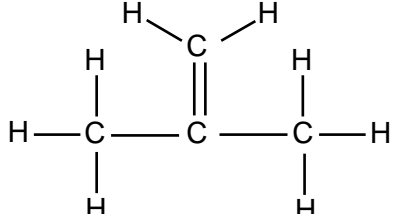
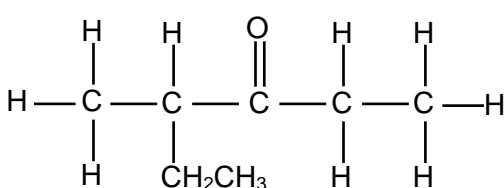
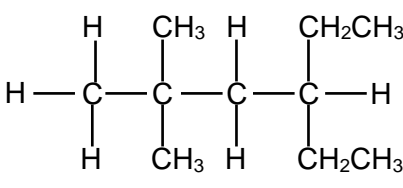
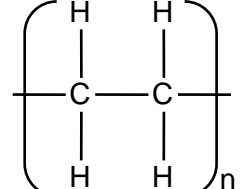
A		B	2-methylbutanoic acid
C		D	
E	But-2-ene	F	

- 2.1 Write down the:
- 2.1.1 NAME of the functional group of compound **B** (1)
- 2.1.2 Homologous series to which compound **C** belongs (1)
- 2.1.3 Type of polymerisation reaction that produces compound **F** (1)
- 2.2 Write down the IUPAC name of:
- 2.2.1 The monomer used to prepare compound **F** (1)
- 2.2.2 Compound **C** (2)
- 2.2.3 Compound **D** (2)
- 2.3 Write down the NAME or FORMULA of each product formed during the complete combustion of compound **D**. (2)
- 2.4 Write down the structural formula of:
- 2.4.1 Compound **B** (2)
- 2.4.2 A CHAIN ISOMER of compound **A** (2)
- 2.5 A laboratory assistant uses bromine water to distinguish between compounds **D** and **E**. She adds bromine water to a sample of each in two different test tubes. She observes that the one compound decolourises the bromine water immediately, whilst the other one only reacts after placing the test tube in direct sunlight. Write down the:
- 2.5.1 Letter (**D** or **E**) of the compound that will immediately decolourise the bromine water (1)
- 2.5.2 Name of the type of reaction that takes place in the test tube containing compound **D** (1)
- 2.5.3 Structural formula of the organic product formed in the test tube containing compound **E** (2)

[18]

QUESTION 3

The letters **A** to **F** in the table below represent six organic compounds.

A	$ \begin{array}{c} \text{H} \quad \text{H} \quad \text{O} \\ \quad \quad \\ \text{H}-\text{C}-\text{C}-\text{C}-\text{O}-\text{H} \\ \quad \\ \text{H} \quad \text{H} \end{array} $	B	$ \begin{array}{cccccccc} & & & & \text{H} & & & \\ & & & & & & & \\ & & & & \text{H}-\text{C}-\text{H} & & & \\ & & & & & & & \\ \text{H} & \text{H} & \text{H} & \text{H} & & \text{H} & \text{H} & \\ & & & & & & & \\ \text{H}-\text{C}-\text{C}-\text{C}-\text{C}-\text{C}-\text{C}-\text{C}-\text{H} \\ & & & & & & & \\ \text{H} & & \text{H} & \text{Cl} & & \text{H} & \text{H} & \\ & & & & & & & \\ & & & & \text{H}-\text{C}-\text{H} & & & \\ & & & & & & & \\ & & & & \text{H} & & & \end{array} $
C	C_4H_8	D	$\text{CH}_3\text{CH}_2\text{COCH}_3$
E	$\text{CH}_3\text{CH}(\text{CH}_3)\text{CH}_2\text{OH}$	F	$ \begin{array}{cccccc} \text{H} & \text{H} & \text{H} & \text{H} & \text{H} & \text{H} \\ & & & & & \\ \text{H}-\text{C}-\text{C}-\text{C}-\text{C}-\text{C}-\text{C}-\text{H} \\ & & & & & \\ \text{H} & \text{H} & \text{H} & \text{H} & \text{H} & \text{H} \end{array} $

Use the information in the table (where applicable) to answer the questions that follow.

- 3.1 Write down the LETTER that represents a compound that:
(A compound may be used more than once.)
- 3.1.1 Is a haloalkane (1)
- 3.1.2 Has a hydroxyl group as functional group (1)
- 3.1.3 Belongs to the same homologous series as ethanoic acid (1)
- 3.2 Write down the:
- 3.2.1 IUPAC name of compound **B** (3)
- 3.2.2 IUPAC name of compound **E** (2)
- 3.2.3 Structural formula of the functional group of compound **D** (1)
- 3.3 Compound **C** has CHAIN and POSITIONAL isomers.
- 3.3.1 Define the term *positional isomer*. (2)
- 3.3.2 Write down the IUPAC name of each of the TWO positional isomers of compound **C**. (4)
- 3.3.3 Write down the structural formula of a chain isomer of compound **C**. (2)
- 3.4 Compound **F** reacts at high pressure and high temperature to form compounds **P** and **Q** as given below.

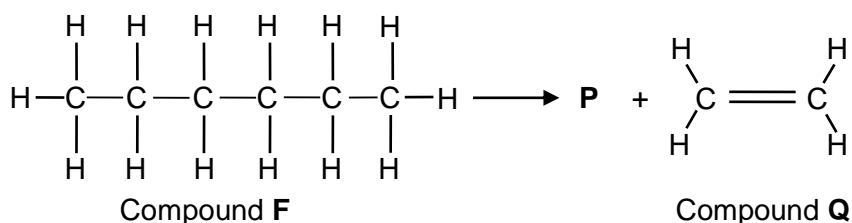

Write down the:

- 3.4.1 Type of reaction that takes place (1)
- 3.4.2 IUPAC name of compound **Q** (1)

3.4.3 Molecular formula of compound **P** (1)

Compound **Q** is the monomer of a polymer used to make plastic bags.

3.4.4 Write down the NAME and CONDENSED FORMULA of this polymer. (3)
[23]

QUESTION 4

The letters **A** to **D** in the table below represent four organic compounds.

A	$ \begin{array}{ccccccc} & \text{H} & & \text{CH}_3 & & \text{H} & & & & \text{H} \\ & & & & & & & & & \\ \text{H} & - \text{C} & - & \text{C} & - & \text{C} & - & \text{C} \equiv \text{C} & - & \text{C} & - & \text{H} \\ & & & & & & & & & \\ & \text{CH}_3 & & \text{H} & & \text{CH}_2\text{CH}_3 & & & & \text{H} \end{array} $	B	$ \begin{array}{ccccccc} & \text{H} & & \text{H} & & \text{O} & & \text{H} \\ & & & & & & & \\ \text{H} & - \text{C} & - & \text{C} & - & \text{C} & - & \text{C} & - & \text{H} \\ & & & & & & & \\ & \text{H} & & \text{H} & & & & \text{H} \end{array} $
C	$\text{CH}_3\text{CH}_2\text{CHO}$	D	Butane

4.1 Write down the:

4.1.1 Letter that represents a ketone (1)

4.1.2 Structural formula of the functional group of compound **C** (1)

4.1.3 General formula of the homologous series to which compound **A** belongs (1)

4.1.4 IUPAC name of compound **A** (3)

4.1.5 IUPAC name of compound **B** (2)

4.2 Compound **D** is a gas used in cigarette lighters.

4.2.1 To which homologous series does compound **D** belong? (1)

4.2.2 Write down the STRUCTURAL FORMULA and IUPAC NAME of a structural isomer of compound **D**. (4)

4.2.3 Is the isomer in QUESTION 4.2.2 a CHAIN, POSITIONAL or FUNCTIONAL isomer? (1)

4.3 Compound **D** reacts with bromine (Br_2) to form 2-bromobutane. Write down the:

4.3.1 Name of the homologous series to which 2-bromobutane belongs (1)

4.3.2 Type of reaction that takes place (1)

[16]

QUESTION 5

5.1 Consider the organic compounds represented by the letters **A** to **C** below.

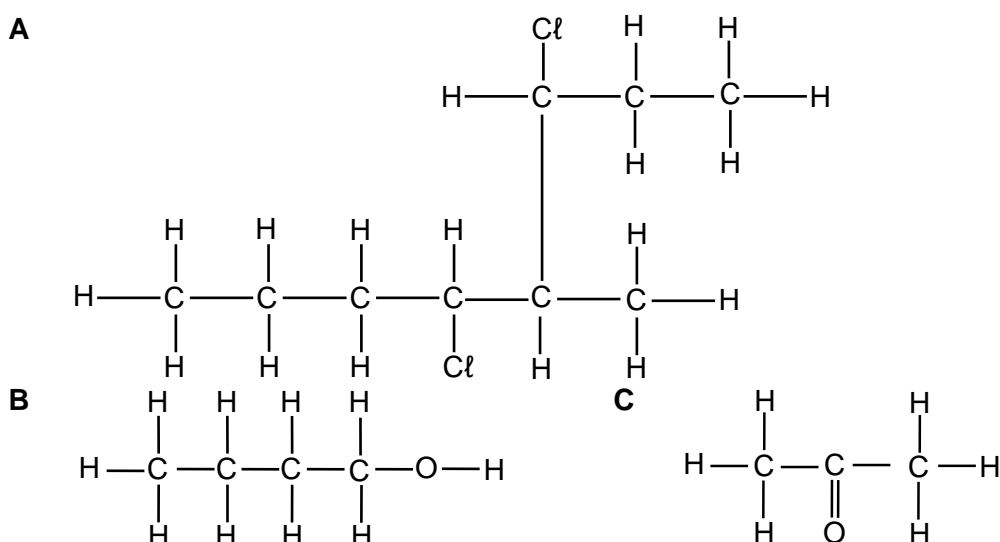

Write down the:

5.1.1 Name of the homologous series to which compound **C** belongs (1)

- 5.1.2 IUPAC name of compound **A** (3)
- 5.1.3 Structural formula of a tertiary alcohol that is a structural isomer of compound **B** (2)
- 5.2 An alcohol and methanoic acid are heated in the presence of concentrated sulphuric acid to form an ester.
- 5.2.1 What is the role of the concentrated sulphuric acid in this reaction? (1)
- 5.2.2 Write down the NAME or FORMULA of the inorganic product formed. (1)
- The ester contains 6,67% hydrogen (H), 40% carbon (C) and 53,33% oxygen (O). The molar mass of the ester is $60 \text{ g}\cdot\text{mol}^{-1}$. Use a calculation to determine its:
- 5.2.3 Empirical formula (5)
- 5.2.4 Molecular formula (3)
- Write down the:
- 5.2.5 Structural formula of methanoic acid (1)
- 5.2.6 IUPAC name of the ester (2)
- [19]**

QUESTION 6

Consider the organic compounds **A** to **F** below.

A		B	
C	$\text{CH}_3\text{CH}_2\text{CH}_2\text{CH}_2\text{OH}$	D	2,2-dimethylpropane
E		F	$\text{CH}_3\text{CHC}(\text{CH}_3)_2$

- 6.1 Write down the LETTER that represents a compound that:
- 6.1.1 Has a carbonyl group (1)
- 6.1.2 Is an alcohol (1)
- 6.1.3 Is a CHAIN ISOMER of $\text{CH}_3(\text{CH}_2)_3\text{CH}_3$ (1)
- 6.2 Write down the:
- 6.2.1 IUPAC name of compound **B** (2)
- 6.2.2 Structural formula of compound **F** (2)
- 6.2.3 IUPAC name of a POSITIONAL isomer of compound **A** (3)
- 6.3 Compound **E** is formed when a carboxylic acid reacts with another organic compound.
- Write down the:
- 6.3.1 Homologous series to which compound **E** belongs (1)
- 6.3.2 NAME or FORMULA of the catalyst used for the preparation of compound **E** (1)
- 6.3.3 IUPAC name of compound **E** (2)
- [14]**

QUESTION 7

The letters **A** to **F** in the table below represent six organic compounds.

A	$ \begin{array}{c} \text{H} \qquad \qquad \text{H} \\ \qquad \qquad \\ \text{H}-\text{C}-\text{C}=\text{C}-\text{H} \\ \qquad \\ \text{H} \qquad \text{C}-\text{H} \\ \\ \text{H} \end{array} $	B	Ethyl ethanoate
C	2,3-dibromo-3-methylpentane	D	Polyethene
E	$ \begin{array}{c} \text{H} \qquad \text{O} \qquad \qquad \text{H} \\ \qquad \qquad \qquad \\ \text{H}-\text{C}-\text{C}-\text{O}-\text{C}-\text{H} \\ \qquad \qquad \qquad \\ \text{H} \qquad \qquad \qquad \text{H} \end{array} $	F	$ \begin{array}{c} \text{H} \qquad \text{H} \qquad \text{H} \qquad \text{O}-\text{H} \\ \qquad \qquad \qquad \\ \text{H}-\text{C}-\text{C}-\text{C}-\text{C}=\text{O} \\ \qquad \qquad \\ \text{H} \qquad \text{H} \qquad \text{H} \end{array} $

- 7.1 Write down the LETTER that represents the following:
- 7.1.1 A hydrocarbon (1)
- 7.1.2 A functional isomer of compound **F** (1)
- 7.1.3 A compound which belongs to the same homologous series as compound **B** (1)
- 7.1.4 A plastic (1)
- 7.2 Write down the STRUCTURAL FORMULA of EACH of the following:
- 7.2.1 Compound **C** (3)
- 7.2.2 The acid used to prepare compound **B** (2)
- 7.2.3 The monomer used to make compound **D** (2)
- 7.3 Compound **A** reacts with an unknown reactant, **X**, to form 2-methylpropane. Write down the:
- 7.3.1 NAME of reactant **X** (1)
- 7.3.2 Type of reaction that takes place (1)

[13]**QUESTION 8**

- 8.1 Define the term functional group of organic compounds. (2)
- 8.2 Write down the:
- 8.2.1 Structural formula of the functional group of aldehydes (1)
- 8.2.2 Name of the functional group of carboxylic acids (1)
- 8.3 The IUPAC name of an organic compound is 2,4-dimethylhexan-3-one. For this compound, write down the:
- 8.3.1 Homologous series to which it belongs (1)
- 8.3.2 Structural formula (3)

8.4 Write down the IUPAC names of the following compounds:

8.4.1

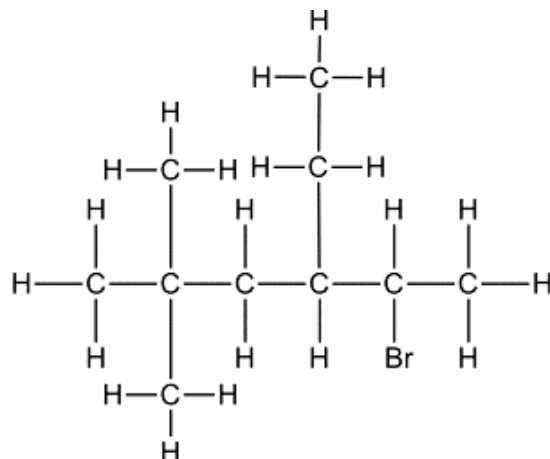

(3)

8.4.2

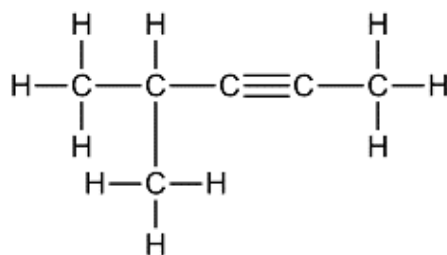

(2)

[13]

QUESTION 9

The letters **A** to **F** in the table below represent six organic compounds.

A	$\text{CH}_3\text{CH}_2\text{CH}_2\text{CHO}$	B	
C	$\text{C}_4\text{H}_8\text{O}$	D	$\text{C}_3\text{H}_8\text{O}$
E		F	

9.1 Write down the letter that represents EACH of the following:

9.1.1 A hydrocarbon

(1)

9.1.2 An alcohol

(1)

9.1.3 An ester

(1)

9.2 Write down the IUPAC name of:

9.2.1 Compound **A**

(1)

9.2.2 Compound **B**

(3)

9.3 Compound **C** is a functional isomer of compound **A**. Write down the structural formula of compound **C**.

(2)

- 11.1 Write down the LETTER that represents EACH of the following:
- 11.1.1 A tertiary alcohol (1)
 - 11.1.2 An aldehyde (1)
 - 11.1.3 A ketone (1)
 - 11.1.4 A functional isomer of compound **B** (1)
- 11.2 Write down the IUPAC name of:
- 11.2.1 Compound **B** (1)
 - 11.2.2 Compound **E** (4)
- 11.3 Define *positional isomers*. (2)
- 11.4 Write down the STRUCTURAL FORMULA of:
- 11.4.1 A positional isomer of compound **C** (2)
 - 11.4.2 Compound **D** (2)
 - 11.4.3 The organic acid that will react with compound **C** to form butyl propanoate (2)
- [17]**

QUESTION 12

Next to each letter, **A** to **F**, in the table below is the molecular formula of an organic compound.

A	C_2H_5Br	B	C_2H_4
C	C_4H_{10}	D	C_2H_6O
E	C_3H_6O	F	$C_3H_6O_2$

- 12.1 Choose a molecular formula above that represents an organic compound below. Write down only the letter (**A** to **F**) next to the question numbers.
- 12.1.1 A haloalkane (1)
 - 12.1.2 An alcohol (1)
 - 12.1.3 An unsaturated hydrocarbon (1)
 - 12.1.4 An aldehyde (1)
 - 12.1.5 A product of thermal cracking of compound **C** (1)
- 12.2 If compound **F** is a carboxylic acid, write down the following:
- 12.2.1 The structural formula of a FUNCTIONAL isomer of **F** (2)
 - 12.2.2 The IUPAC name of a FUNCTIONAL isomer of **F** (2)
- 12.3 Compound **B** is a monomer used to make a polymer. Write down the:
- 12.3.1 Definition of a *polymer* (2)
 - 12.3.2 IUPAC name of the polymer (1)
 - 12.3.3 Balanced equation for the polymerisation reaction (3)
- 12.4 Compound **A** is used as a reactant in the production of compound **D**. Name the type of reaction that takes place. (1)
- 12.5 State TWO changes that can be made to the reaction conditions in QUESTION 12.4 to obtain compound **B**, instead of **D**, as product. (2)
- [18]**

QUESTION 13

A test tube containing a straight chain organic acid **X**, ethanol and a catalyst is heated in a water bath, as illustrated below.

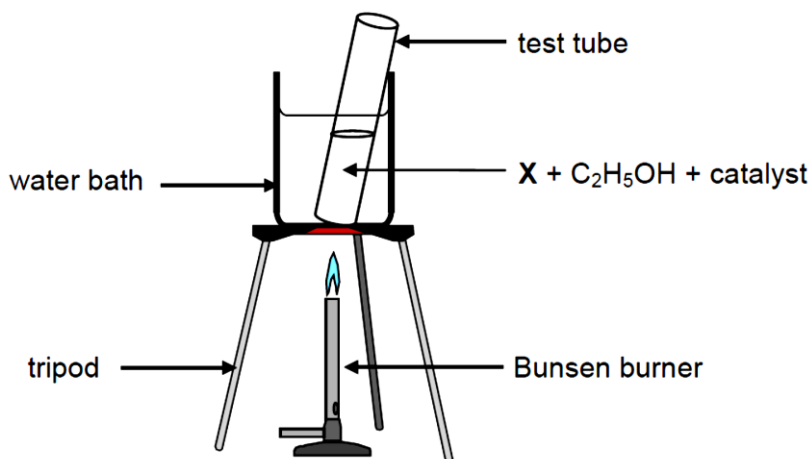

Organic compound **Y** is produced according to the following equation:

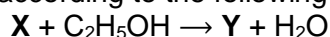

- 13.1 Give a reason why the test tube is heated in a water bath instead of directly over the flame. (1)
- 13.2 Write down the:
- 13.3.1 Type of reaction that takes place here (1)
- 13.3.2 FORMULA of the catalyst needed (1)
- 13.3.3 Homologous series to which compound **Y** belongs (1)

The molecular mass of compound **Y** is $144 \text{ g} \cdot \text{mol}^{-1}$ and its empirical formula is $\text{C}_4\text{H}_8\text{O}$.

- 13.3 Determine the molecular formula of compound **Y**. (2)
- 13.4 Write down the IUPAC name of compound **Y**. (2)
- 13.5 Write down the structural formula of the organic acid **X**. (2)

[10]**ORGANIC MOLECULES: PHYSICAL PROPERTIES****QUESTION 1**

- 1.1 Give a reason why alkanes are *saturated* hydrocarbons. (1)
- 1.2 Write down the structural formula of:
- 1.2.1 The functional group of alcohols (1)
- 1.2.2 A tertiary alcohol that is a structural isomer of butan-1-ol (2)
- 1.3 Learners investigate factors that influence the boiling points of alkanes and alcohols. In one of the investigations they determine the boiling points of the first three alkanes.
- 1.3.1 Write down an investigative question for this investigation. (2)
- 1.3.2 Fully explain why the boiling point increases from methane to propane. (3)
- 1.4 The learners find that the boiling point of propan-1-ol is higher than that of propane. Explain this observation by referring to the TYPE of INTERMOLECULAR FORCES present in each of these compounds. (3)

[12]

QUESTION 2

Learners use compounds **A** to **C**, shown in the table below, to investigate a factor which influences the boiling point of organic compounds.

A	CH ₃ CH ₂ CH ₂ CH ₃
B	CH ₃ CH ₂ CH ₂ CH ₂ CH ₃
C	CH ₃ CH ₂ CH ₂ CH ₂ CH ₂ CH ₃

- 2.1 Which ONE of the compounds (**A**, **B** or **C**) has the highest boiling point? (1)
- 2.2 For this investigation, write down the:
- 2.2.1 Independent variable (1)
- 2.2.2 Dependent variable (1)
- 2.3 Write down the name of the type of Van der Waals force that occurs between the molecules of compound **B**. (1)
- 2.4 How will the vapour pressure of 2-methylpentane compare to that of compound **C**? Write down only HIGHER THAN, LOWER THAN or EQUAL TO. (1)

The learners now compare the boiling points of compounds **D** and **E**, shown in the table below.

D	CH ₃ CH ₂ CH ₂ CH ₂ CH ₂ OH
E	CH ₃ CH ₂ CH ₂ COOH

- 2.5 How does the boiling point of compound **D** compare to that of compound **E**? Write down HIGHER THAN, LOWER THAN or EQUAL TO. Fully explain the answer. (4)

[9]**QUESTION 3**

The table below shows five organic compounds represented by the letters **A** to **E**.

A	CH ₄
B	CH ₃ CH ₃
C	CH ₃ CH ₂ CH ₃
D	CH ₃ CH ₂ CH ₂ CH ₃
E	CH ₃ CH ₂ OH

- 3.1 Is compound **B** SATURATED or UNSATURATED? Give a reason for the answer. (2)
- Consider the boiling points of compounds **A** to **E** given in random order below and use them, where applicable, to answer the questions that follow.

0 °C	- 162 °C	- 42 °C	- 89 °C	78 °C
------	----------	---------	---------	-------

- 3.2 Write down the boiling point of:
- 3.2.1 Compound **C** (1)
- 3.2.2 Compound **E** (1)
- 3.3 Explain the difference in boiling points of compounds **C** and **E** by referring to the TYPE of intermolecular forces present in EACH of these compounds. (3)
- 3.4 Does vapour pressure INCREASE or DECREASE from compounds **A** to **D**? Fully explain the answer. (4)
- 3.5 How will the vapour pressure of 2-methylpropane compare to the vapour pressure of compound **D**? Write down only HIGHER THAN, LOWER THAN or EQUAL TO. (1)

[12]

QUESTION 4

Four compounds of comparable molecular mass are used to investigate the effect of functional groups on vapour pressure. The results obtained are shown in the table below.

COMPOUND		VAPOUR PRESSURE (kPa at 20 °C)
A	Butane	204
B	Propan-2-one	24,6
C	Propan-1-ol	2
D	Ethanoic acid	1,6

- 4.1 Define the term *functional group* of an organic compound. (2)
- 4.2 Which ONE of the compounds (**A**, **B**, **C** or **D**) in the table has the:
- 4.2.1 Highest boiling point
(Refer to the vapour pressures in the table to give a reason for the answer.) (2)
- 4.2.2 Weakest intermolecular forces (1)
- 4.3 Refer to the type of intermolecular forces to explain the difference between the vapour pressure of compound **A** and compound **B**. (3)
- 4.4 The vapour pressures of compounds **C** and **D** are much lower than those of compounds **A** and **B**. Name the type of intermolecular force in **A** and **B** that is responsible for this difference. (1)
- 4.5 Briefly explain the difference in vapour pressure between compound **C** and compound **D**. (2)
- 4.6 During a combustion reaction in a closed container of adjustable volume, 8 cm³ of compound **A** (butane) reacts in excess oxygen according to the following balanced equation:

$$2\text{C}_4\text{H}_{10}(\text{g}) + 13\text{O}_2(\text{g}) \rightarrow 8\text{CO}_2(\text{g}) + 10\text{H}_2\text{O}(\text{g})$$
 If the initial volume of the oxygen in the container was 60 cm³, calculate the TOTAL volume of the gases that are present in the container at the end of the reaction. All the gases in the container are at the same temperature and pressure. (5)

[16]**QUESTION 5**

- 5.1 Define the term *boiling point*. (2)
- 5.2 What is the relationship between strength of intermolecular forces and boiling point? (1)

The relationship between strength of intermolecular forces and boiling point is investigated using four organic compounds from different homologous series. The compounds and their boiling points are given in the table below.

COMPOUND		BOILING POINT (°C)
A	Propane	- 42
B	Propan-2-one	56
C	Propan-1-ol	97
D	Propanoic acid	141

- 5.3 Refer to the TYPE and the STRENGTH of intermolecular forces to explain the difference in boiling points between:
- 5.3.1 Compounds **A** and **B** (3)
- 5.3.2 Compounds **C** and **D** (3)
- 5.4 Is compound **B** a GAS or a LIQUID at room temperature? (1)

[10]

QUESTION 6

The relationship between boiling point and the number of carbon atoms in straight chain molecules of alkanes, carboxylic acids and alcohols is investigated. Curves **P**, **Q** and **R** are obtained.

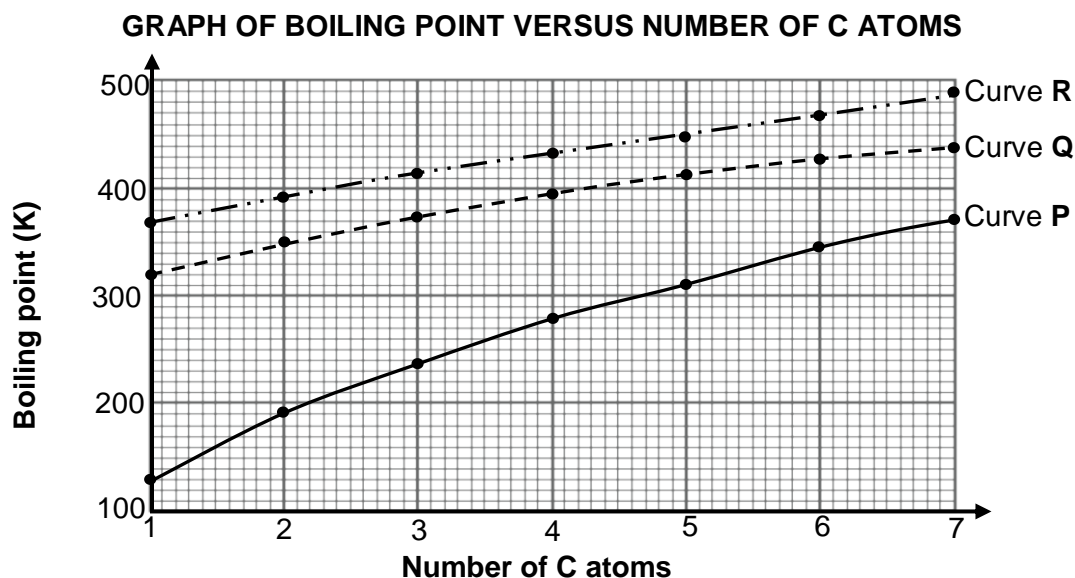

- 6.1 Define the term *boiling point*. (2)
- 6.2 For curve **P**, write down a conclusion that can be drawn from the above results. (2)
- 6.3 Identify the curve (**P**, **Q** or **R**) that represents each of the following:
- 6.3.1 Alkanes (1)
- 6.3.2 Carboxylic acids (1)
- 6.4 Explain the answer to QUESTION 6.3.2 by referring to the:
- Types of intermolecular forces present in alkanes, carboxylic acids and alcohols
 - Relative strengths of these intermolecular forces
 - Energy needed
- (5)
[11]

QUESTION 7

The boiling points of three isomers are given in the table below.

	ISOMERS	BOILING POINT (°C)
A	2,2-dimethylpropane	9
B	2-methylbutane	28
C	pentane	36

- 7.1 Define the term *structural isomer*. (2)
- 7.2 What type of isomers (POSITIONAL, CHAIN or FUNCTIONAL) are these three compounds? (1)
- 7.3 Explain the trend in the boiling points from compound **A** to compound **C**. (3)
- 7.4 Which ONE of the three compounds (**A**, **B** or **C**) has the highest vapour pressure? Refer to the data in the table to give a reason for the answer. (2)
- 7.5 Use MOLECULAR FORMULAE and write down a balanced equation for the complete combustion of compound **B**. (3)
- [11]

QUESTION 8

The boiling points of some organic compounds are given in the table below.
Y represents an unknown boiling point.

	COMPOUND	BOILING POINT (°C)
A	Methanol	64,7
B	Ethanol	78,3
C	Propan-1-ol	97,2
D	Butan-1-ol	117,7
E	Butan-2-ol	99,5
F	2-methylpropan-1-ol	Y
G	2-methylpropan-2-ol	82,5

- 8.1 For the compounds listed above, write down the:
- 8.1.1 Structural formula of compound **F** (3)
- 8.1.2 LETTER that represents a POSITIONAL isomer of compound **E** (1)
- 8.1.3 LETTER that represents a CHAIN isomer of compound **E** (1)
- 8.2 The boiling points increase from compound **A** to compound **D**.
- 8.2.1 Give a reason for this increase in terms of the molecular structure. (1)
- 8.2.2 Name the intermolecular force in these compounds responsible for this increase. (1)
- 8.3 Consider the boiling points given below.
- | | | |
|-------|--------|--------|
| 85 °C | 108 °C | 122 °C |
|-------|--------|--------|
- 8.3.1 From these boiling points, choose the boiling point represented by **Y** in the table above. (1)
- 8.3.2 Fully explain how you arrived at the answer to QUESTION 8.3.1. (4)
- 8.4 Hydrogen bonding is responsible for the relatively high boiling points of compounds **A** to **G** in comparison with hydrocarbons of similar molecular size.
Draw TWO structural formulae of compound **A**. Use a dotted line to show the hydrogen bonding between the two structural formulae. (2)
- 8.5 Compound **B** reacts with propanoic acid in the presence of concentrated sulphuric acid. Write down the:
- 8.5.1 Type of reaction that takes place (1)
- 8.5.2 Structural formula of the organic product formed (2)

[17]**QUESTION 9**

Learners investigate factors which influence the boiling points of alcohols. They use equal volumes of each of the alcohols and heat them separately in a water bath. The temperature at which each boils is measured. The results obtained are shown in the table below.

ALCOHOLS	BOILING POINTS OF ALCOHOLS (°C)
Butan-1-ol	117,7
Pentan-1-ol	138,5
Hexan-1-ol	157,0

- 9.1 Define the term *boiling point*. (2)
- 9.2 What property of alcohols requires them to be heated in a water bath? (1)
- 9.3 The boiling points of the alcohols are compared with each other.
- 9.3.1 What structural requirements must the alcohols meet to make it a fair comparison? (2)

- 9.3.2 Fully explain the trend in the boiling points. (3)
- 9.4 How will the boiling point of hexan-1-ol be affected if the volume of hexan-1-ol used is doubled? Choose from INCREASES, DECREASES or REMAINS THE SAME. (1)
- 9.5 In another investigation the learners compare the boiling points of hexan-1-ol and hexanal.
- 9.5.1 Write down the independent variable for this comparison. (1)
- 9.5.2 They find that the boiling point of hexan-1-ol is higher than that of hexanal. Fully explain this observation. (4)
- [14]

QUESTION 10

The vapour pressure versus temperature graph below was obtained for four straight chain (unbranched) alkanes (**P**, **Q**, **R** and **S**). FROM **P** TO **S**, EACH COMPOUND DIFFERS FROM THE PREVIOUS COMPOUND BY A $-\text{CH}_2$ GROUP.

The vapour pressures are measured in mmHg. Atmospheric pressure is 760 mmHg.

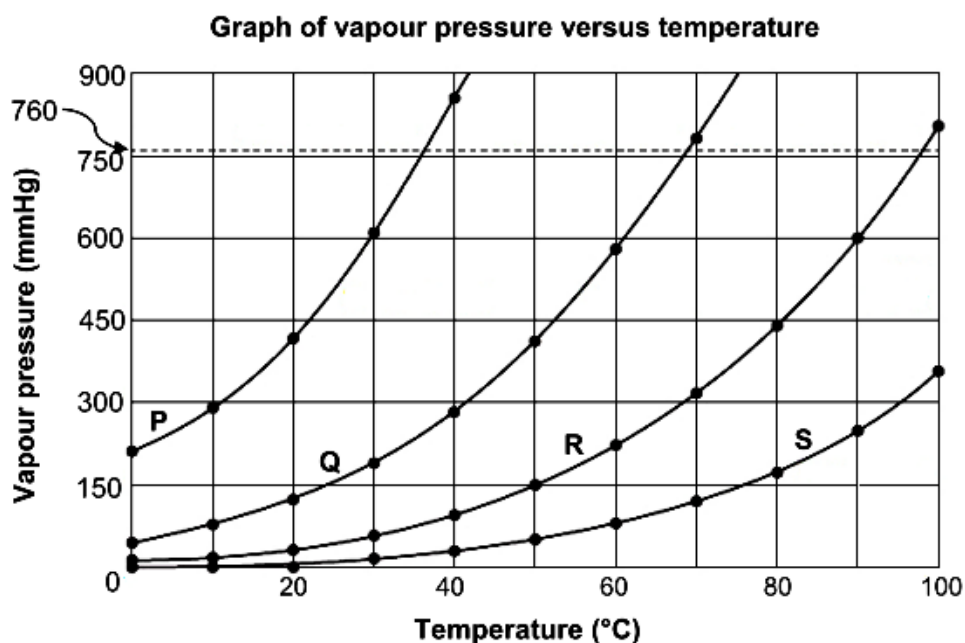

- 10.1 Give a reason why alkanes are said to be SATURATED. (1)
- 10.2 Define vapour pressure. (2)
- 10.3 Use the information in the graph above to answer the following questions.
- 10.3.1 What is the effect of an increase in temperature on vapour pressure? Choose from INCREASES, DECREASES or NO EFFECT. (1)
- 10.3.2 Which compound has a boiling point of approximately 68 °C? Give a reason for the answer. (2)
- 10.3.3 Which compound has the longest chain length? Fully explain the answer. (4)
- 10.4 Compound **P** has FIVE carbon atoms.
- 10.4.1 Draw the structural formula of a chain isomer of **P**. Write down the IUPAC name of this isomer. (3)
- 10.4.2 How will the vapour pressure of this isomer compare with that of compound **P**? Choose from HIGHER THAN, LOWER THAN or EQUAL TO. (1)

[14]

QUESTION 11

Study the vapour pressure versus temperature graphs for three organic compounds, **X**, **Y** and **Z**, below which belong to different homologous series. Atmospheric pressure is 100 kPa.

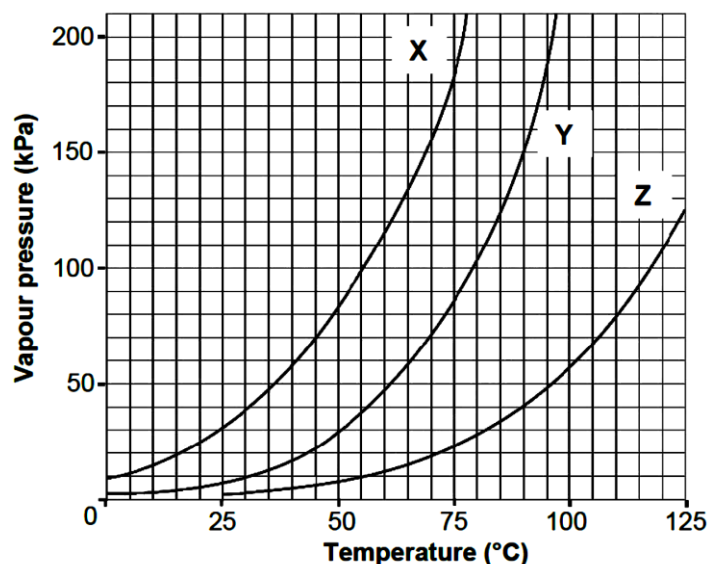
Graphs of vapour pressure versus temperature

- 11.1 Write down the vapour pressure of compound **Y** at 90 °C. (1)
- 11.2 The graphs can be used to determine the boiling points of the three compounds. (2)
- 11.2.1 Define *boiling point*. (2)
- 11.2.2 Determine the boiling point of compound **X**. (1)
- 11.3 The homologous series to which the three compounds of similar molecular masses belong, were identified in random order as: alcohol; carboxylic acid; ketone
- 11.3.1 Which compound (**X**, **Y** or **Z**) is the carboxylic acid? (1)
- 11.3.2 Explain the answer to QUESTION 11.3.1 by referring to the type of intermolecular forces in compounds of each of the homologous series above. (4)
- 11.3.3 Compound **X** has three carbon atoms per molecule. Write down the IUPAC name of compound **X**. (1)

[10]**QUESTION 12**

The boiling points of straight-chain alkanes and straight-chain alcohols are compared in the table.

NUMBER OF CARBON ATOMS	BOILING POINTS OF ALKANES (°C)	BOILING POINTS OF ALCOHOLS (°C)
1	- 162	64
2	- 89	78
3	- 42	98
4	- 0,5	118

- 12.1 Explain the increase in boiling points of the alkanes, as indicated in the table. (3)
- 12.2 Explain the difference between the boiling points of an alkane and an alcohol, each having THREE carbon atoms per molecule, by referring to the TYPE of intermolecular forces. (4)
- 12.3 Does the vapour pressure of the alcohols INCREASE or DECREASE with an increase in the number of carbon atoms? (1)
- 12.4 How will the boiling point of 2-methylpropane compare to that of its chain isomer? Write down HIGHER THAN, LOWER THAN or EQUAL TO. Give a reason for the answer by referring to the structural differences between the two compounds. (2)

[10]

QUESTION 13

The boiling points of different organic compounds are given below.

COMPOUND		BOILING POINT (°C)
A	HCOOH	101
B	CH ₃ COOH	118
C	CH ₃ CH ₂ COOH	141
D	CH ₃ CH ₂ CH ₂ COOH	164

- 13.1 Define *boiling point*. (2)
- 13.2 Write down the:
- 13.2.1 Name of the FUNCTIONAL GROUP of these compounds (1)
- 13.2.2 IUPAC name of compound C (1)
- 13.2.1 Structural formula of the FUNCTIONAL isomer of compound **B** (2)
- 13.3 Which ONE of the compounds, **A** or **B** or **C**, has the highest vapour pressure? Refer to the data in the table to give a reason for the answer. (2)
- 13.4 The boiling point of compound **B** is now compared with of compound **X**.

COMPOUND		BOILING POINT (°C)
B	CH ₃ COOH	118
X	CH ₃ CH ₂ CH ₂ OH	98

- 13.4.1 Besides the conditions used to determine boiling points, give a reason why this is a fair comparison. (1)
- 13.4.2 Is compound **X** a PRIMARY, SECONDARY or TERTIARY alcohol? Give a reason for the answer. (2)
- 13.4.3 Fully explain the difference between the boiling points by referring to the types of intermolecular forces present in each of these compounds. (4)

[15]**ORGANIC MOLECULES: ORGANIC REACTIONS****QUESTION 1**

The flow diagram below shows the preparation of an ester using prop-1-ene as a starting reagent. **P**, **Q**, **R** and **S** represent different organic reactions.

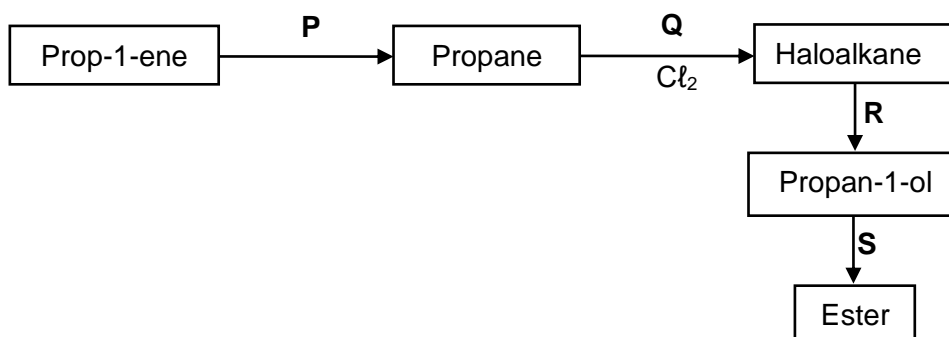

- 1.1 Write down the type of reaction represented by:
- 1.1.1 **Q** (1)
- 1.1.2 **R** (1)
- 1.2 For reaction **P** write down the:
- 1.2.1 Type of addition reaction (1)
- 1.2.2 Balanced equation using structural formulae (3)

- 1.3 Write down the structural formula of the haloalkane formed in reaction **Q**. (2)
- 1.4 In reaction **S** propan-1-ol reacts with ethanoic acid to form the ester. For this reaction write down the:
- 1.4.1 Name of the reaction that takes place (1)
- 1.4.2 FORMULA or NAME of the catalyst needed (1)
- 1.4.3 Structural formula of the ester formed (2)
- 1.4.4 IUPAC name of the ester formed (2)
- 1.5 The propan-1-ol formed in reaction **R** can be converted to prop-1-ene. Write down the FORMULA or NAME of the inorganic reagent needed. (1)
- [15]**

QUESTION 2

In the flow diagram below, but-1-ene is used as starting material in the preparation of compound **A**.

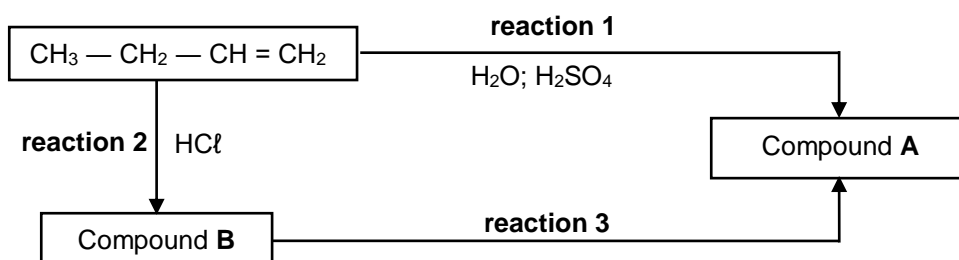

- 2.1 Is but-1-ene a SATURATED or UNSATURATED compound? Give a reason for the answer. (2)
- 2.2 Compound **A** is the major product formed in **reaction 1**. Write down the:
- 2.2.1 Structural formula of compound **A** (2)
- 2.2.2 Type of reaction that takes place (1)
- 2.3 For compound **B**, write down the:
- 2.3.1 IUPAC name (2)
- 2.3.2 Structural formula of the positional isomer (2)
- 2.4 For **reaction 3**, write down:
- 2.4.1 TWO reaction conditions needed (2)
- 2.4.2 The type of reaction that occurs (1)
- 2.4.3 A balanced equation, using molecular formulae (3)
- [15]**

QUESTION 3

Consider the incomplete equations of two reactions below. **X** represents the organic product formed in **reaction 1**, which is a SUBSTITUTION REACTION. In **reaction 2**, **X** reacts with reactant **Y** as shown.

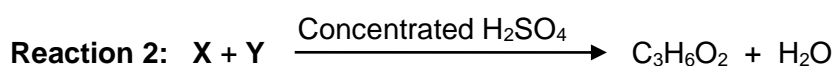
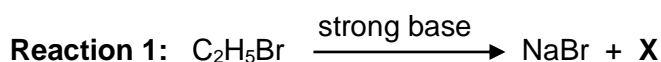

- 3.1 Consider **reaction 1**. Write down the:
- 3.1.1 Type of substitution reaction that takes place (1)
- 3.1.2 TWO reaction conditions (2)
- 3.1.3 IUPAC name of compound **X** (1)

3.2 Consider **reaction 2**. Write down the:

- 3.2.1 Type of reaction that takes place (1)
 3.2.2 Structural formula of compound **Y** (2)
 3.2.3 IUPAC name of the organic product (2)

[9]

QUESTION 4

4.1 The flow diagram below shows two organic reactions. The letter **P** represents an organic compound.



Use the information in the flow diagram to answer the questions that follow. Write down the:

- 4.1.1 Type of reaction of which **Reaction 1** is an example (1)
 4.1.2 STRUCTURAL FORMULA of the functional group of ethyl propanoate (1)
 4.1.3 IUPAC name of compound **P** (1)

Reaction 2 takes place in the presence of an acid catalyst and heat.

Write down the:

- 4.1.4 Type of reaction of which **Reaction 2** is an example (1)
 4.1.5 NAME or FORMULA of the acid catalyst (1)
 4.1.6 STRUCTURAL FORMULA of the alkene (2)

4.2 The condensed formula of a polymer is shown below.

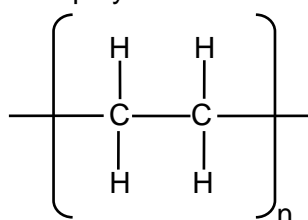

Write down the:

- 4.2.1 STRUCTURAL FORMULA of the monomer that is used to prepare the above polymer (2)
 4.2.2 Type of polymerisation reaction (ADDITION or CONDENSATION) that is used to prepare this polymer (1)

[10]

QUESTION 5

The flow diagram below shows different organic reactions using $\text{CH}_2 = \text{CH}_2$ as the starting reactant. **X**, **Y** and **Z** represent different organic compounds.

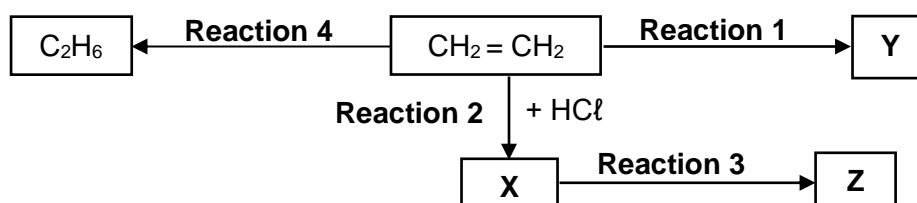

5.1 During **Reaction 1**, $\text{CH}_2 = \text{CH}_2$ undergoes polymerisation to form compound **Y**. For this reaction, write down the:

- 5.1.1 Type of polymerisation (1)

- 5.1.2 NAME of compound **Y** (1)
- 5.2 For **Reaction 2**, write down the:
- 5.2.1 IUPAC name of compound **X** (2)
- 5.2.2 Type of addition reaction of which this is an example (1)
- 5.3 During **Reaction 3**, compound **X** reacts with excess hot water. Write down the:
- 5.3.1 STRUCTURAL FORMULA of compound **Z** (2)
- 5.3.2 NAME or FORMULA of the INORGANIC product (1)
- 5.4 **Reaction 4** is an addition reaction.
- 5.4.1 Is C_2H_6 a SATURATED or an UNSATURATED compound? Give a reason for the answer. (2)
- 5.4.2 Write down the NAME or FORMULA of the INORGANIC reactant needed for this reaction. (1)
- 5.4.3 Using molecular formulae, write down a balanced equation for the complete combustion of C_2H_6 . (3)
- [14]**

QUESTION 6

The flow diagram below shows how prop-1-ene can be used to prepare other organic compounds.

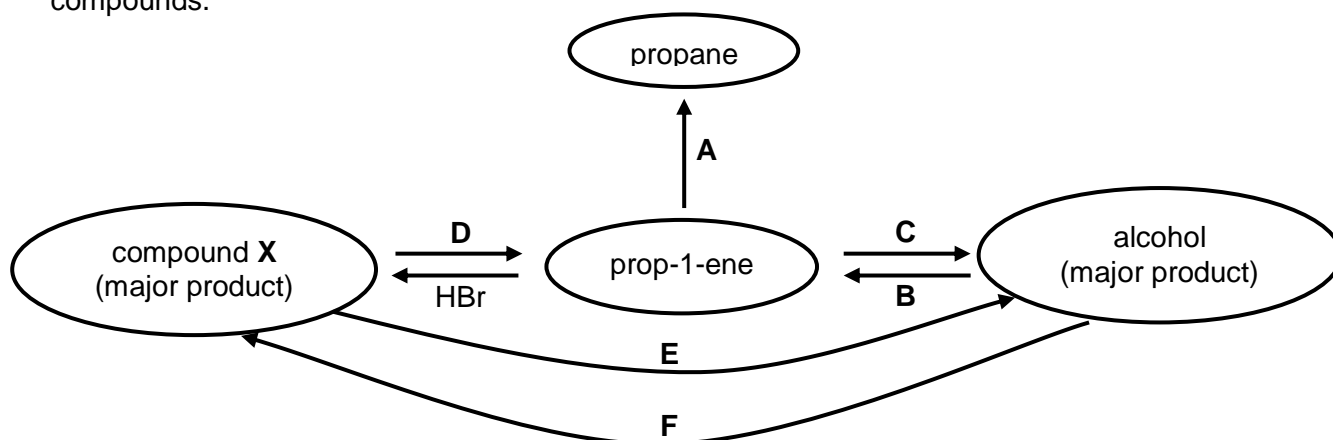

- 6.1 Write down the type of reaction represented by:
- 6.1.1 **A** (1)
- 6.1.2 **D** (1)
- 6.1.3 **F** (1)
- 6.2 Write down the:
- 6.2.1 NAME or FORMULA of the catalyst needed for reaction **A** (1)
- 6.2.2 NAME or FORMULA of the inorganic reagent needed for reaction **B** (1)
- 6.2.3 Type of addition reaction represented by reaction **C** (1)
- 6.2.4 IUPAC name of compound **X** (2)
- 6.3 Use structural formulae to write down a balanced equation for reaction **B**. (5)
- 6.4 Both reactions **D** and **E** take place in the presence of a strong base. State TWO conditions that will favour reaction **D** over reaction **E**. (2)
- [15]**

QUESTION 7

Butane (C_4H_{10}) is produced in industry by the THERMAL cracking of long-chain hydrocarbon molecules, as shown in the equation below. **X** represents an organic compound that is produced.

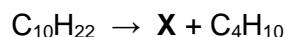

7.1 Write down:

7.1.1 ONE condition required for THERMAL cracking to take place (1)

7.1.2 The molecular formula of compound **X** (1)

7.1.3 The homologous series to which compound **X** belongs (1)

7.2 A mixture of the two gases, compound **X** and butane, is bubbled through bromine water, $Br_2(aq)$, in a conical flask, as illustrated below. THE REACTION IS CARRIED OUT IN A DARKENED ROOM.

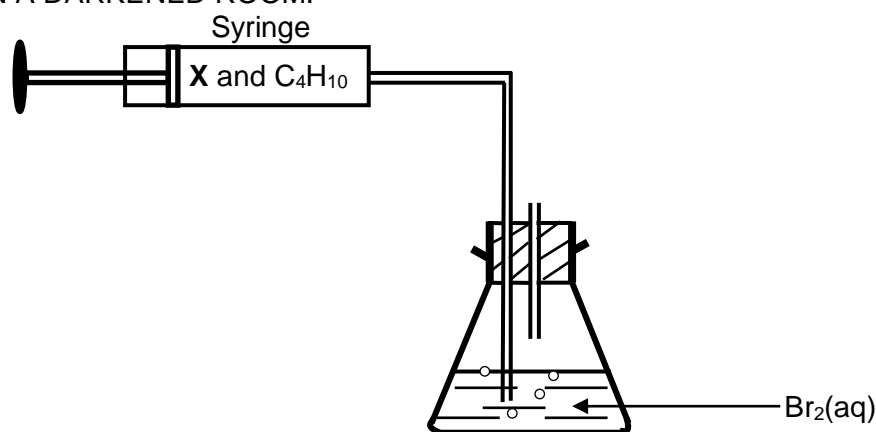

The colour of the bromine water changes from reddish brown to colourless when the mixture of the two gases is bubbled through it.

Which ONE of the gases (**X** or BUTANE) decolorises the bromine water? Explain the answer. (4)

7.3 Study the flow diagram below, which represents various organic reactions, and answer the questions that follow.

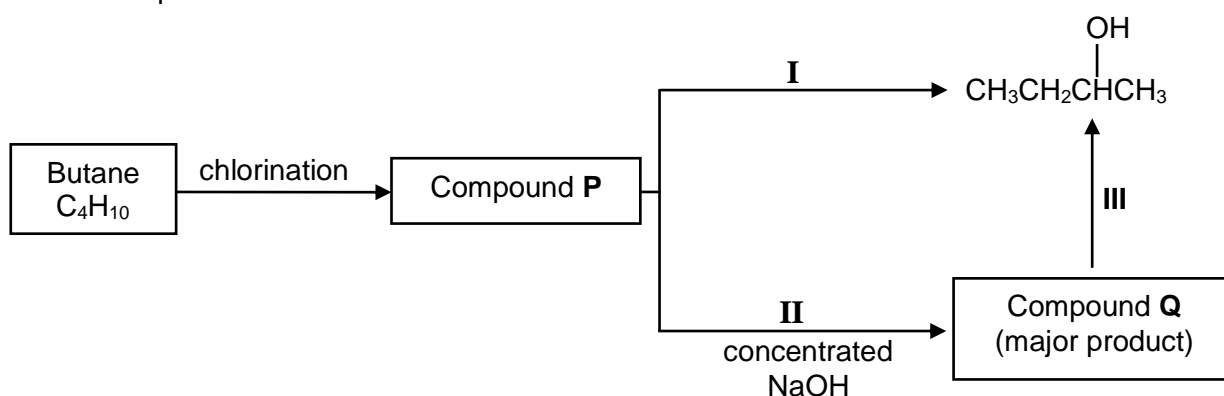

Write down the:

7.3.1 IUPAC name of compound **P** (2)

7.3.2 Type of reaction labelled **I** (1)

7.3.3 Structural formula of compound **Q** (2)

7.3.4 The type of addition reaction represented by reaction **III** (1)

[13]

QUESTION 8

The flow diagram below shows how an alkene can be used to prepare other organic compounds. The letters **A** to **G** represent different organic reactions.

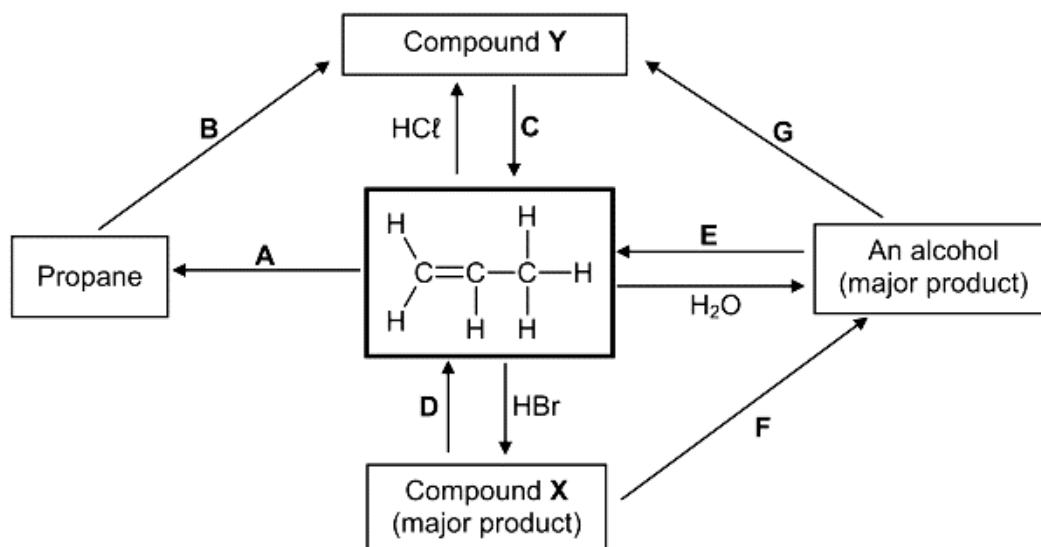

- 8.1 Write down the type of reaction represented by:
- 8.1.1 **A** (1)
- 8.1.2 **B** (1)
- 8.1.3 **E** (1)
- 8.2 Write down the IUPAC name of compound **X**. (2)
- 8.3 For reaction **D**, write down:
- 8.3.1 The type of elimination reaction (1)
- 8.3.2 TWO reaction conditions (2)
- 8.4 Write down the:
- 8.4.1 FORMULA of an inorganic reactant needed for reaction **F** (1)
- 8.4.2 Balanced equation, using structural formulae, for reaction **G** (4)
- [13]**

QUESTION 9

- 9.1 Consider the reactions represented in the flow diagram below.

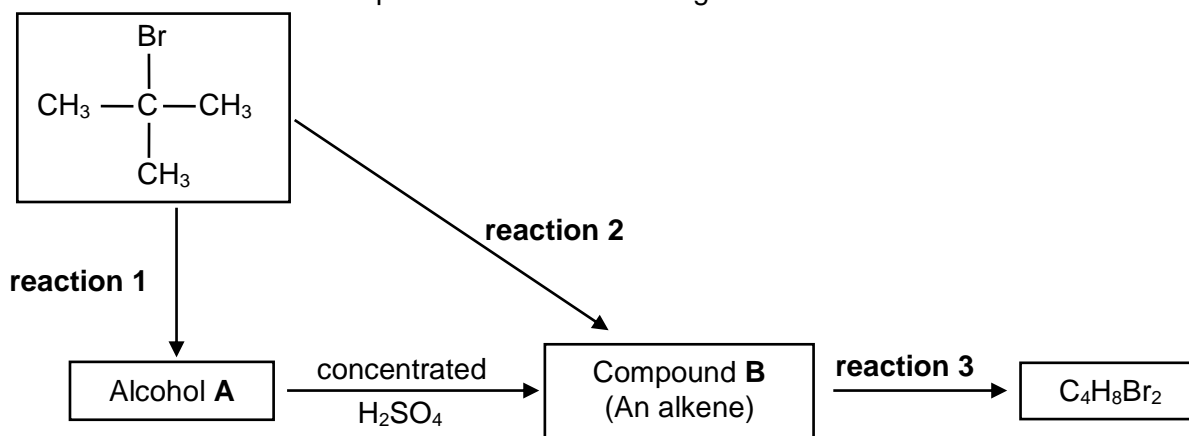

Write down the:

- 9.1.1 Type of reaction represented by **reaction 1** (1)
- 9.1.2 NAME or FORMULA of the inorganic reactant needed for **reaction 1** (1)

- 9.1.3 Type of alcohol (PRIMARY, SECONDARY or TERTIARY) of which alcohol **A** is an example (1)
- 9.1.4 Type of reaction represented by **reaction 2** (1)
- 9.1.5 IUPAC name of compound **B** (2)
- 9.1.6 Type of addition reaction represented by **reaction 3** (1)
- 9.1.7 Balanced equation for **reaction 3** using structural formulae (4)
- 9.2 A wide range of synthetic polymers are produced by combining large numbers of similar small organic molecules bonded to each other in a repeating pattern. Polymer **C** below is an example of such a polymer.

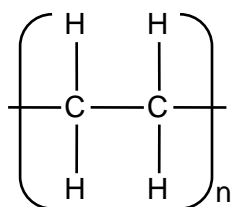

Polymer C

Write down:

- 9.2.1 ONE word for the underlined phrase (1)
- 9.2.2 The homologous series to which the 'small organic molecules' used to produce polymer **C** belong (1)
- 9.2.3 The type of polymerisation which takes place to produce polymer **C** (1)

[14]

QUESTION 10

The flow diagram below shows how an alcohol (compound **P**) can be used to prepare other organic compounds. The letters **A** to **E** represent different organic reactions. **X**, **Y** and **Z** are organic compounds.

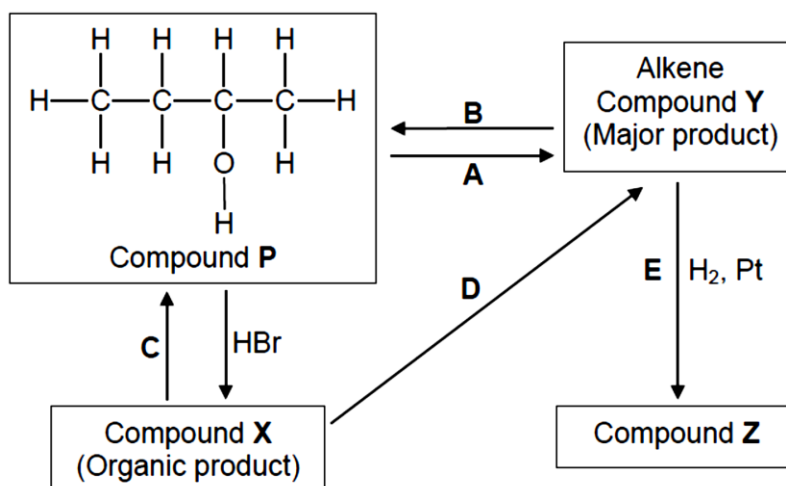

- 10.1 Is compound P a PRIMARY, SECONDARY or TERTIARY alcohol? Give a reason for the answer.
- 10.2 Write down the type of:
- 10.2.1 Elimination reaction represented by **A** (1)
- 10.2.2 Addition reaction represented by **B** (1)
- 10.2.3 Elimination reaction represented by **D** (1)
- 10.3 Sodium hydroxide is used as one of the reactants in reaction **C**.
- 10.3.1 What type of reaction takes place here? (1)
- 10.3.2 State the TWO reaction conditions for this reaction. (2)

- 10.3.3 Write down the IUPAC name of compound **X**. (2)
- 10.4 Write down the FORMULA of an inorganic reactant needed for reaction **D**. (1)
- 10.5 Using STRUCTURAL FORMULAE, write down a balanced equation for reaction **E**. (3)
- 10.6 Write down the IUPAC name of compound **Z**. (1)
- [15]**

QUESTION 11

Consider the incomplete equations for reactions **I** to **IV** below. **P**, **Q**, **R** and **S** are organic compounds.

I	$Q + Br_2 \longrightarrow 2\text{-bromobutane} + HBr$
II	$nP \longrightarrow \left[CH_2 - CH_2 \right]_n$
III	$R \xrightarrow{\text{heat}} 2P + Q$
IV	$2\text{-bromobutane} + KOH \text{ (in ethanol)} \xrightarrow{\text{heat}} S + T + H_2O$

- 11.1 Define a *cracking reaction*. (2)
- 11.2 Write down the reaction number (**I**, **II**, **III** or **IV**) that represents EACH of the following:
- 11.2.1 A cracking reaction (1)
- 11.2.2 An addition reaction (1)
- 11.2.3 A substitution reaction (1)
- 11.3 Write down:
- 11.3.1 ONE reaction condition for reaction **I** (1)
- 11.3.2 The compound (**P**, **Q**, **R** or **S**) that represents an unsaturated hydrocarbon (1)
- 11.3.3 The IUPAC name of compound **P** (1)
- 11.3.4 The molecular formula of compound **R** (2)
- 11.3.5 The structural formula of compound **Q** (2)
- 11.3.6 The structural formula of compound **S** (2)
- [14]**

QUESTION 12

Propan-1-ol can undergo a number of organic reactions, as indicated by the letters **A** to **D** in the diagram below.

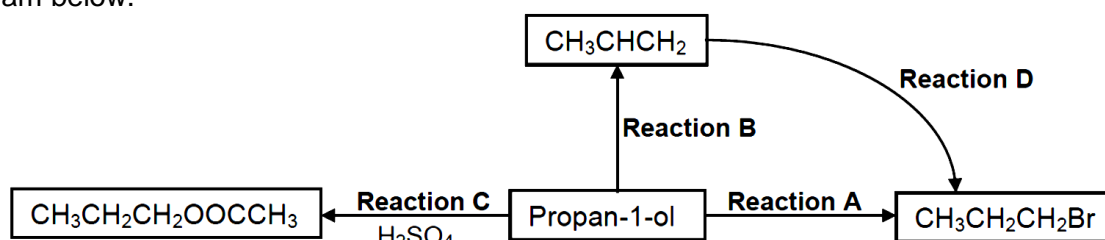

- 12.1 Write down the type of reaction represented by:
- 12.1.1 **A** (1)
- 12.1.2 **B** (1)
- 12.1.3 **C** (1)

- 12.1.4 **D** (1)
- 12.2 For reaction **C**, write down the:
- 12.2.1 Function of H_2SO_4 (1)
- 12.2.2 IUPAC name of the organic product (2)
- 12.2.3 Structural formula of the other organic reactant (2)
- 12.3 Use STRUCTURAL FORMULAE for all organic reactants and products to write a balanced equation for **reaction A**. (5)

[14]**QUESTION 13**

- 13.1 Three reactions of organic compounds from the same homologous series are shown below.

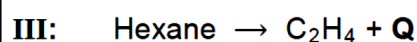
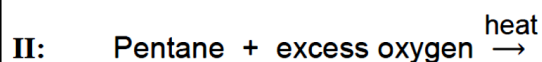
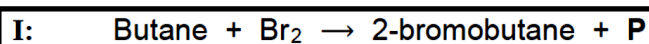

- 13.1.1 Define a *homologous series*. (2)
- 13.1.2 Name the type of reaction represented by **I**. (1)
- 13.1.3 Write down the formula of the inorganic compound **P**. (1)
- 13.1.4 Give the structural formula of a POSITIONAL isomer of 2-bromobutane. (2)
- 13.1.5 Using molecular formulae, write down a balanced equation for reaction **II**. (3)
- Reaction **III** is an example of a cracking reaction.
- 13.1.6 Define a *cracking reaction*. (2)
- 13.1.7 Give the structural formula of organic compound **Q**. (2)
- 13.2 Study the flow diagram below.

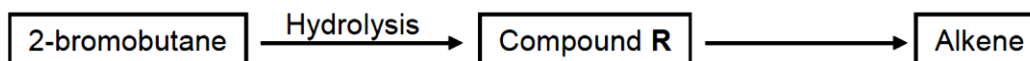

- 13.2.1 Write down the IUPAC name of compound **R**. (2)
- 13.2.2 Compound **R** reacts in the presence of concentrated phosphoric acid to form an alkene. Write down the structural formula of the MAJOR PRODUCT in this reaction. (2)

[17]**REACTION RATE AND ENERGY IN CHEMICAL REACTIONS****QUESTION 1**

- 1.1 Define the term *reaction rate* in words. (2)

Learners use the reaction between IMPURE POWDERED calcium carbonate and excess hydrochloric acid to investigate reaction rate. The balanced equation for the reaction is:

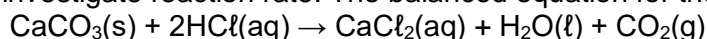

They perform four experiments under different conditions of concentration, mass and temperature as shown in the table below. They use identical apparatus in the four experiments and measure the volume of gas released in each experiment.

	EXPERIMENT			
	1	2	3	4
Concentration of acid ($\text{mol}\cdot\text{dm}^{-3}$)	1	0,5	1	1
Mass of impure calcium carbonate (g)	15	15	15	25
Initial temperature of acid ($^{\circ}\text{C}$)	30	30	40	40

- 1.2 The results of experiments **1** and **3** are compared in the investigation. Write down the:
- 1.2.1 Independent variable (1)
- 1.2.2 Dependent variable (1)
- 1.3 Use the collision theory to explain why the reaction rate in experiment **4** will be higher than that in experiment **3**. (3)

The learners obtain graphs **A**, **B**, **C** and **D** below from their results.

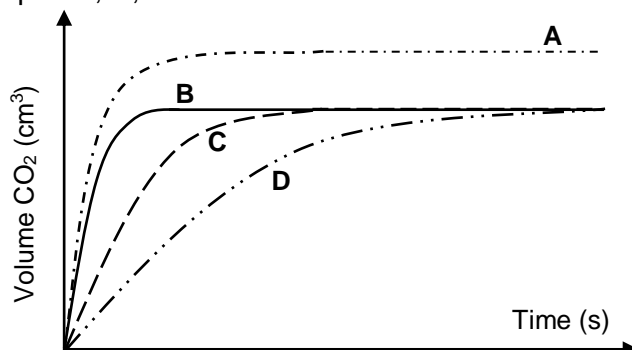

- 1.4 Which ONE of the graphs (**A**, **B**, **C** or **D**) represents experiment **1**? Fully explain the answer by comparing experiment **1** with experiments **2**, **3** and **4**. (6)
- 1.5 When the reaction in experiment **4** reaches completion, the volume of gas formed is $4,5 \text{ dm}^3$. Assume that the molar gas volume at 40°C is equal to $25,7 \text{ dm}^3$. Calculate the mass of the impurities present in the calcium carbonate. (5) [18]

QUESTION 2

A group of learners uses the reaction of EXCESS hydrochloric acid (HCl) with zinc (Zn) to investigate factors which influence reaction rate. The balanced equation for the reaction is:

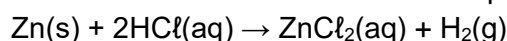

They use the same volume of hydrochloric acid and $1,2 \text{ g}$ of zinc in each of five experiments. The reaction conditions and temperature readings before and after completion of the reaction in each experiment are summarised in the table below.

Experiment	REACTION CONDITIONS			Time (s)	
	Concentration of HCl ($\text{mol}\cdot\text{dm}^{-3}$)	Temperature ($^\circ\text{C}$)			
		Before	After		
1	0,5	20	34	granules	50
2	0,5	20	35	powder	10
3	0,8	20	36	powder	6
4	0,5	35	50	granules	8
5	0,5	20	34	granules	11

- 2.1 Is the reaction between hydrochloric acid and zinc EXOTHERMIC or ENDOTHERMIC? Give a reason for the answer by referring to the data in the table. (2)
- 2.2 Give a reason for the difference in reaction rate observed for **Experiments 1** and **2**. (1)
- 2.3 The learners compare the results of **Experiments 1** and **3** to draw a conclusion regarding the effect of concentration on reaction rate. Give a reason why this is not a fair comparison. (1)
- 2.4 How does the rate of the reaction in **Experiment 5** compare to that in **Experiment 1**? Write down FASTER THAN, SLOWER THAN or EQUAL TO. Write down the factor responsible for the difference in the rate of reaction and fully explain, by referring to the collision theory, how this factor affects reaction rate. (5)
- 2.5 Calculate the rate at which the hydrochloric acid reacts in **Experiment 4** in $\text{mol}\cdot\text{s}^{-1}$. (6) [15]

QUESTION 3

A group of learners uses the reaction of clean magnesium ribbon with dilute hydrochloric acid to investigate factors that influence reaction rate. The balanced equation for the reaction is:

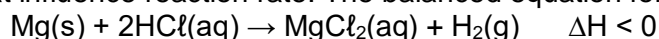

3.1 Is the above reaction EXOTHERMIC or ENDOTHERMIC? Give a reason for the answer. (2)

3.2 In one of the experiments 5 g magnesium ribbon was added to the hydrochloric acid solution.

3.2.1 If 30 cm³ dilute hydrochloric acid solution of concentration 1,5 mol·dm⁻³ is USED UP in 1 minute, calculate the average reaction rate in mol·s⁻¹. (5)

The volume of hydrogen gas produced as a function of time in this experiment is represented by graph **S** below. (The graph is NOT drawn to scale.)

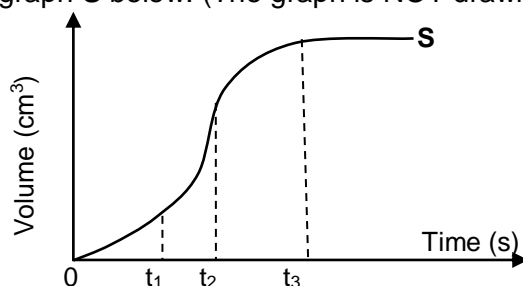

3.2.2 How does the rate of the reaction change between: (Write down INCREASES, DECREASES or NO CHANGE.)

(a) t_1 and t_2
Use the collision theory to explain the answer. (4)

(b) t_2 and t_3
Give a reason for the answer without referring to the graph. (2)

3.3 In another experiment they add 5 g of magnesium to 30 cm³ of dilute hydrochloric acid of concentration 1,5 mol·dm⁻³. They obtained graph **T** below. (The graph is NOT drawn to scale.)

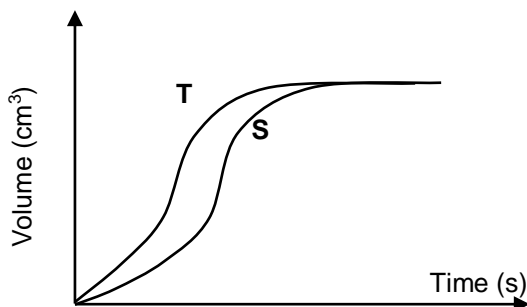

Give TWO possible reasons why graph **T** differs from graph **S**.

(2)
[15]

QUESTION 4

Dilute acids, indicated in the table below, react with EXCESS zinc in each of the three experiments to produce hydrogen gas. The zinc is completely covered with the acid in each experiment.

EXPERIMENT	DILUTE ACID
1	100 cm ³ of 0,1 mol·dm ⁻³ H ₂ SO ₄
2	50 cm ³ of 0,2 mol·dm ⁻³ H ₂ SO ₄
3	100 cm ³ of 0,1 mol·dm ⁻³ HCl

The volume of hydrogen gas produced is measured in each experiment.

4.1 Name TWO essential apparatuses needed to determine the rate of hydrogen production. (2)

The graph below was obtained for **Experiment 1**.

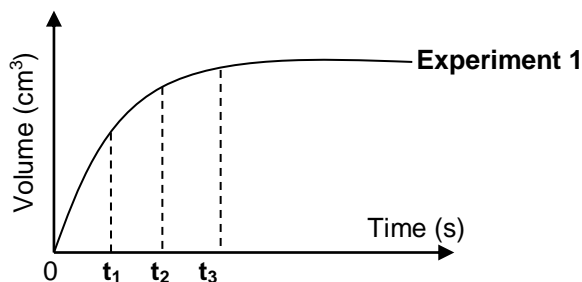

Use this graph and answer the questions that follow.

- 4.2 At which time (t_1 , t_2 or t_3) is the:
- 4.2.1 Reaction rate the highest (1)
- 4.2.2 Mass of zinc present in the flask the smallest (1)
- 4.3 In which time interval, **between t_1 and t_2** OR **between t_2 and t_3** , does the largest volume of hydrogen gas form per second? (1)
- 4.4 Redraw the graph for **Experiment 1** in the ANSWER BOOK. On the same set of axes, sketch the graphs that will be obtained for **Experiments 2** and **3**. Clearly label the three graphs as **EXPERIMENT 1**, **EXPERIMENT 2** and **EXPERIMENT 3**. (4)
- 4.5 The initial mass of zinc used in each experiment is 0,8 g. The balanced equation for the reaction in **Experiment 3** is: $\text{Zn(s)} + 2\text{HCl(aq)} \rightarrow \text{ZnCl}_2\text{(aq)} + \text{H}_2\text{(g)}$
- 4.5.1 Calculate the mass of zinc present in the flask after completion of the reaction in **Experiment 3**. (5)
- 4.5.2 How will the mass of zinc present in the flask after completion of the reaction in **Experiment 2** compare to the answer to QUESTION 4.5.1? Write down only LARGER THAN, SMALLER THAN or EQUAL TO. (1)

[15]

QUESTION 5

Methanol and hydrochloric acid react according to the following balanced equation:

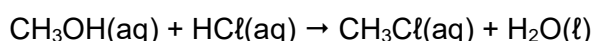

- 5.1 State TWO factors that can INCREASE the rate of this reaction. (2)
- 5.2 Define the term *reaction rate*. (2)
- 5.3 The rate of the reaction between methanol and hydrochloric acid is investigated. The concentration of HCl(aq) was measured at different time intervals. The following results were obtained:

TIME (MINUTES)	HCl CONCENTRATION ($\text{mol}\cdot\text{dm}^{-3}$)
0	1,90
15	1,45
55	1,10
100	0,85
215	0,60

- 5.3.1 Calculate the average reaction rate, in $(\text{mol}\cdot\text{dm}^{-3})\cdot\text{min}^{-1}$ during the first 15 minutes. (3)
- 5.3.2 Use the data in the table to draw a graph of concentration versus time on a graph paper. **NOTE:** The graph is not a straight line. (3)
- 5.3.3 From the graph, determine the concentration of HCl(aq) at the 40th minute. (1)
- 5.3.4 Use the collision theory to explain why the reaction rate decreases with time. Assume that the temperature remains constant. (3)

- 5.3.5 Calculate the mass of $\text{CH}_3\text{Cl}(\text{aq})$ in the flask at the 215th minute. The volume of the reagents remains 60 cm^3 during the reaction. (5) [19]

QUESTION 6

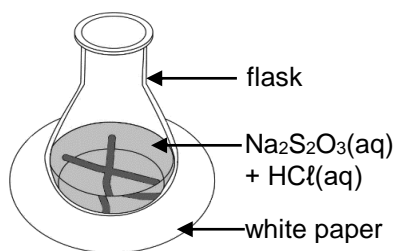

The reaction between dilute hydrochloric acid and sodium thiosulphate ($\text{Na}_2\text{S}_2\text{O}_3$) is used to investigate one of the factors that influences reaction rate. The balanced equation for the reaction is:



The hydrochloric acid solution is added to the sodium thiosulphate solution in a flask. The flask is placed over a cross drawn on a sheet of white paper, as shown in the diagram below. The time that it takes for the cross to become invisible is measured to determine the reaction rate.

Four experiments, **A** to **D**, are conducted during this investigation. The volumes of reactants used in each of the four experiments and the times of the reactions are summarised in the table below.

Experiment	Volume of $\text{Na}_2\text{S}_2\text{O}_3(\text{aq})$ (cm^3)	Volume of $\text{H}_2\text{O}(\text{l})$ (cm^3)	Volume of $\text{HCl}(\text{aq})$ (cm^3)	Time (s)
A	25	0	5	50,0
B	20	5	5	62,5
C	15	10	5	83,3
D	10	15	5	125,0

- 6.1 State TWO factors that can influence the rate of the reaction above. (2)
- 6.2 Write down the NAME or FORMULA of the product that causes the cross to become invisible. (1)
- 6.3 Give a reason why water is added to the reaction mixture in experiments **B** to **D**. (1)
- 6.4 Write down an investigative question for this investigation. (2)
- 6.5 In which experiment (**A**, **B**, **C** or **D**) is the reaction rate the highest? (1)
- 6.6 Use the collision theory to explain the difference in reaction rate between experiments **B** and **D**. (3)
- 6.7 The original $\text{Na}_2\text{S}_2\text{O}_3$ solution was prepared by dissolving 62,50 g $\text{Na}_2\text{S}_2\text{O}_3$ crystals in distilled water in a 250 cm^3 volumetric flask. Calculate the mass of sulphur, S, that will form in experiment **D** if $\text{Na}_2\text{S}_2\text{O}_3$ is the limiting reactant. (7) [17]

QUESTION 7

Hydrogen peroxide, H_2O_2 , decomposes to produce water and oxygen according to the following balanced equation: $2\text{H}_2\text{O}_2(\text{l}) \rightarrow 2\text{H}_2\text{O}(\text{l}) + \text{O}_2(\text{g})$

- 7.1 The activation energy (E_A) for this reaction is 75 kJ and the heat of reaction (ΔH) is -196 kJ.

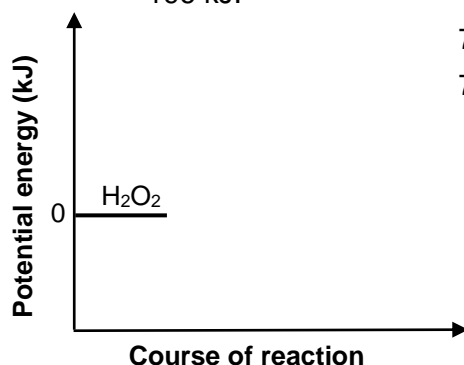

- 7.1.1 Define the term *activation energy*. (2)
- 7.1.2 Redraw the set of axes alongside in your ANSWER BOOK and then complete the potential energy diagram for this reaction. Indicate the value of the potential energy of the following on the y-axis:
- Activated complex
 - Products
- (The graph does NOT have to be drawn to scale.) (3)

When powdered manganese dioxide is added to the reaction mixture, the rate of the reaction increases.

7.1.3 On the graph drawn for QUESTION 7.1.2, use broken lines to show the path of the reaction when the manganese dioxide is added. (2)

7.1.4 Use the collision theory to explain how manganese dioxide influences the rate of decomposition of hydrogen peroxide. (3)

7.2 Graphs **A** and **B** below were obtained for the volume of oxygen produced over time under different conditions.

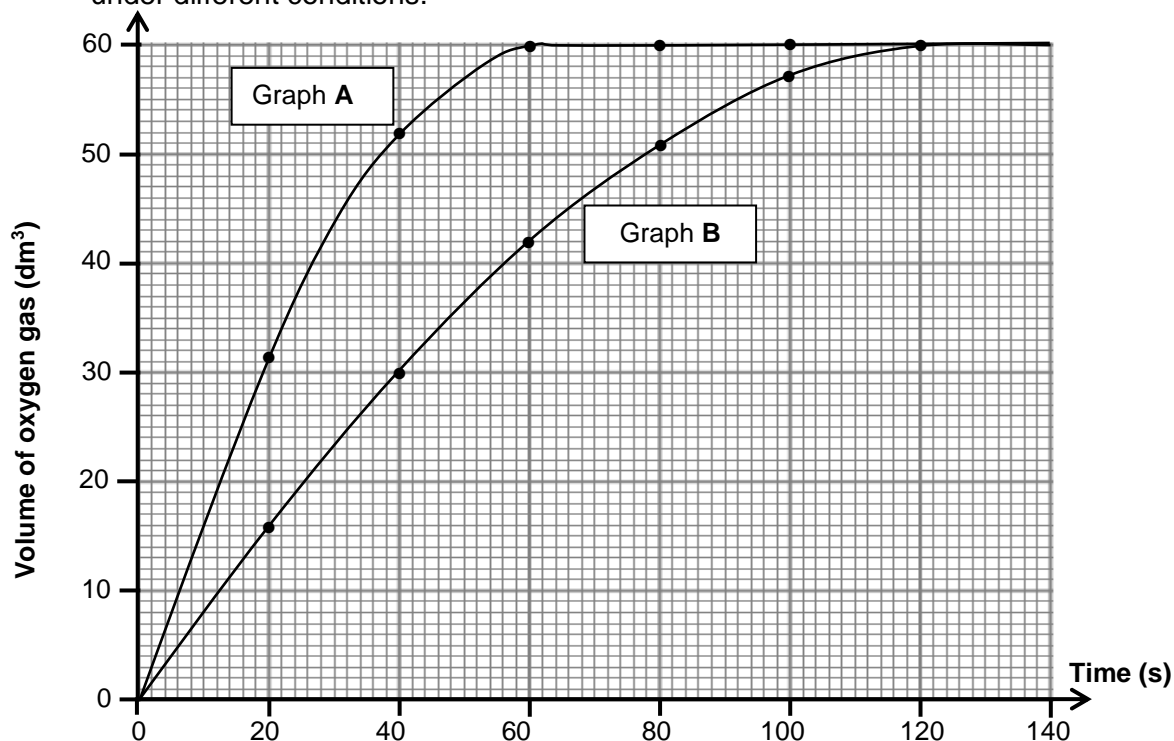

7.2.1 Calculate the average rate of the reaction (in $\text{dm}^3 \cdot \text{s}^{-1}$) between $t = 10 \text{ s}$ and $t = 40 \text{ s}$ for graph **A**. (3)

7.2.2 Use the information in graph **A** to calculate the mass of hydrogen peroxide used in the reaction. Assume that all the hydrogen peroxide decomposed. Use $24 \text{ dm}^3 \cdot \text{mol}^{-1}$ as the molar volume of oxygen. (4)

7.2.3 How does the mass of hydrogen peroxide used to obtain graph **B** compare to that used to obtain graph **A**? Choose from GREATER THAN, SMALLER THAN or EQUAL TO. (1)

7.3 Three energy distribution curves for the oxygen gas produced under different conditions are shown in the graph below. The curve with the solid line represents 1 mol of oxygen gas at 90°C .

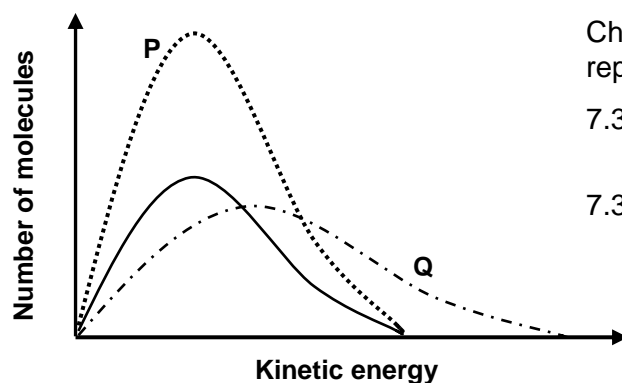

Choose the curve (**P** or **Q**) that best represents EACH of the following situations:

7.3.1 1 mol of oxygen gas produced at 120°C (1)

7.3.2 2 moles of oxygen gas produced at 90°C (1)

[20]

QUESTION 8

The apparatus below is used to investigate one of the factors that affects the rate of decomposition of hydrogen peroxide, H_2O_2 . The balanced equation for the reaction is:

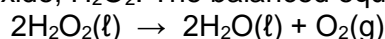

Two experiments are conducted. The reaction conditions are as follows:

Experiment I: 50 cm³ of hydrogen peroxide is allowed to decompose at 30 °C.

Experiment II: 50 cm³ of hydrogen peroxide decompose at 30 °C in the presence of copper(II) oxide powder (CuO).

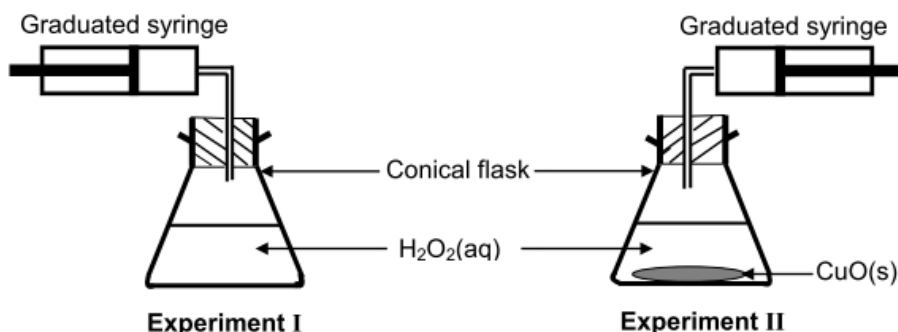

The results of the investigation are summarised in the table below.

Experiment	Total volume of O ₂ (g) produced(dm ³)	Time taken for complete decomposition (min.)
I	0,4	12,3
II	0,4	5,8

- 8.1 For this investigation, write down the function of the:
- 8.1.1 Graduated syringe (1)
- 8.1.2 Copper(II) oxide (1)
- 8.2 How will you know when the reaction is completed? (1)
- 8.3 Write down the independent variable for this investigation. (1)
- 8.4 Use the collision theory to fully explain the difference in reaction rates of experiment I and experiment II. (3)
- 8.5 The graphs below show changes in the potential energy during the decomposition of hydrogen peroxide in experiment I and experiment II.

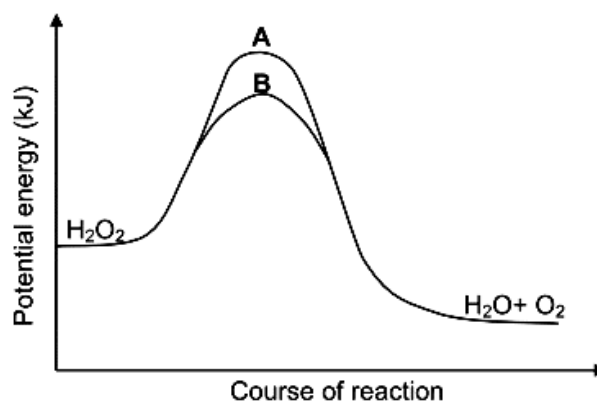

- 8.5.1 Is energy ABSORBED or RELEASED during this reaction? Give a reason for the answer. (2)
- 8.5.2 Which ONE of the curves, A or B, represents experiment II? (1)
- 8.6 Calculate the rate, in mol·dm⁻³·min⁻¹, at which 50 cm³ of hydrogen peroxide decomposes in experiment II. Assume that 1 mole of gas occupies a volume of 25 dm³ at 30 °C. (6)

[16]

QUESTION 9

The reaction of copper(II) carbonate with excess dilute hydrochloric acid is used to investigate the rate of reaction. The balanced equation for the reaction is:

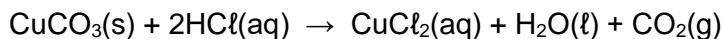

The apparatus used is illustrated below.

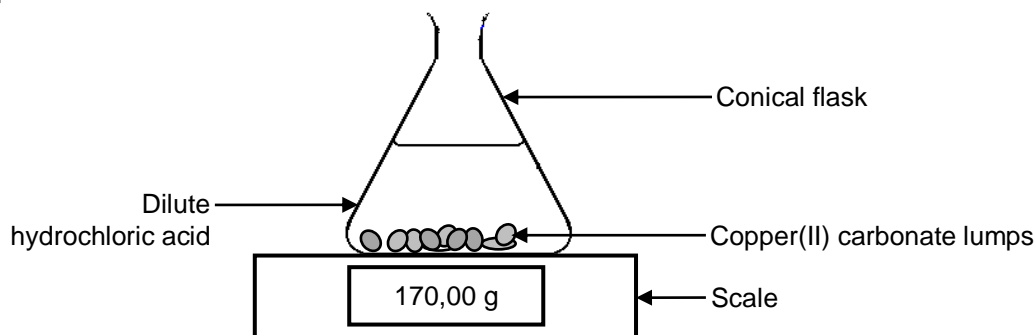

9.1 State TWO ways in which the rate of the reaction above can be increased. (2)

During the investigation, samples of both PURE and IMPURE copper(II) carbonate of EQUAL mass are used. The graphs below are obtained from the results.

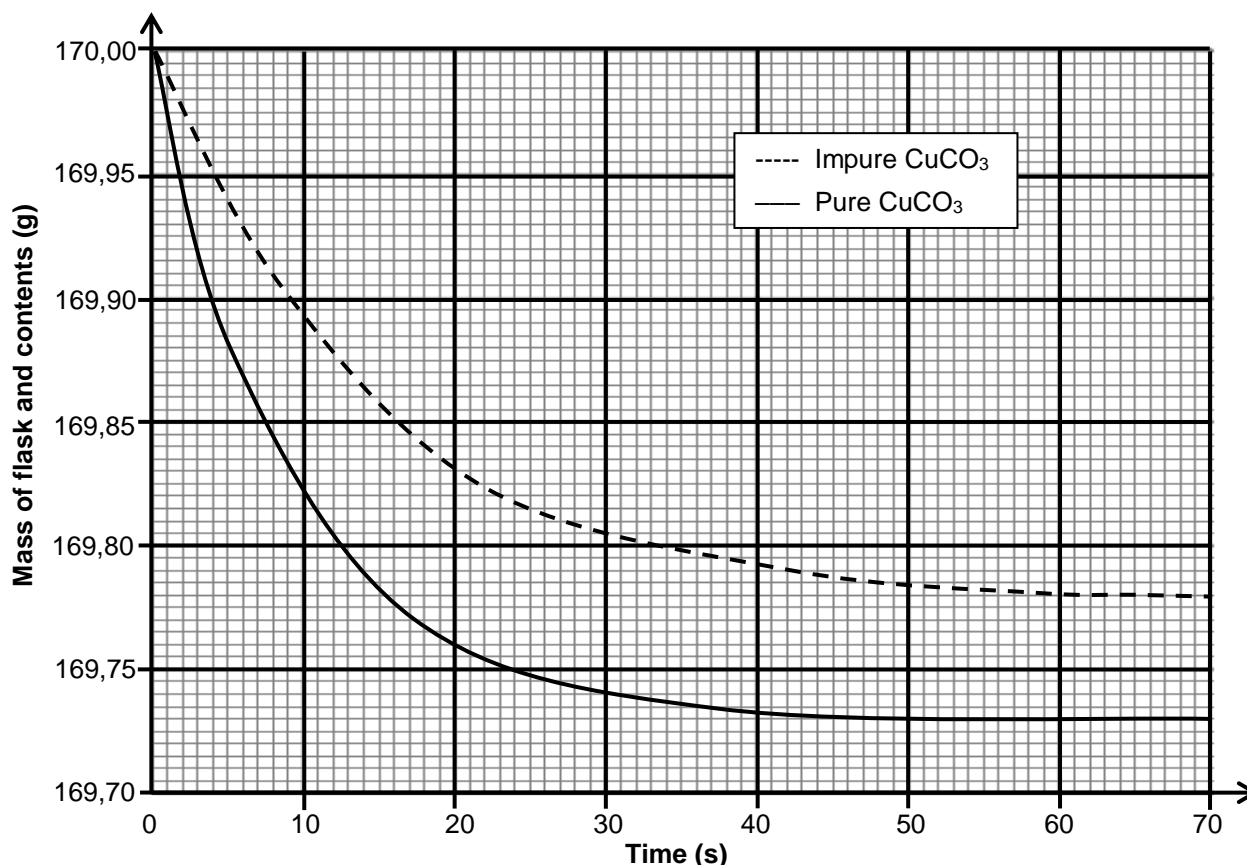

9.2 Write down the reaction time for the reaction of the pure CuCO₃ with HCl. (1)

9.3 Assume that all the gas formed during the two reactions escape from the flask and that the impurities do not react. Calculate the:

9.3.1 Average rate of the reaction of the pure sample over the first 20 s (3)

9.3.2 Percentage purity of the impure sample (4)

9.3.3 Maximum volume of CO₂(g) produced during the reaction of the pure sample of CuCO₃ if the reaction takes place at STANDARD CONDITIONS (3)

9.4 Sketch a graph of the volume of gas produced versus time for the reaction of the pure CuCO₃. Indicate the reaction time on the x-axis. (2)

[15]

QUESTION 10

A group of learners uses the reaction between powdered zinc and EXCESS dilute hydrochloric acid to investigate one of the factors that affects the rate of a chemical reaction. The balanced equation for the reaction is: $\text{Zn(s)} + 2\text{HCl(aq)} \rightarrow \text{ZnCl}_2\text{(aq)} + \text{H}_2\text{(g)}$

They conduct two experiments. The reaction conditions used are summarised in the table below.

EXPERIMENT	TEMPERATURE (°C)	VOLUME OF HCl (cm ³)	CONCENTRATION OF HCl (mol·dm ⁻³)	MASS OF Zn (g)
I	25	200	0,25	x
II	25	200	0,40	x

The results obtained are shown in the graph (not drawn to scale) below.

Graph of volume of H₂(g) produced versus time

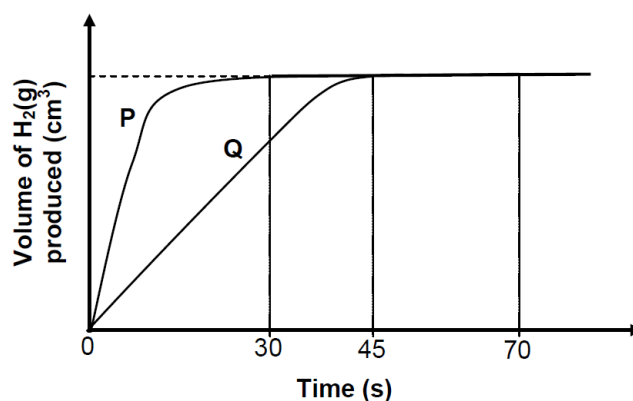

- 10.1 Define *reaction rate*. (2)
- 10.2 Write down an investigative question for this investigation. (2)
- 10.3 Which curve, **P** or **Q**, represents the results of experiment **I**? Explain the answer. (3)
- 10.4 The average rate of the production of hydrogen gas, as represented by graph **P**, was $15 \text{ cm}^3 \cdot \text{s}^{-1}$. Calculate the mass of zinc used. **Take the molar gas volume at 25 °C as 24 000 cm³.** (5)
- 10.5 In a third experiment (experiment **III**), 200 cm³ of a 0,25 mol·dm⁻³ dilute hydrochloric acid solution at 35 °C reacts with the same amount of zinc powder as in experiment **I** and experiment **II**. (2)
- 10.5.1 How will the heat of reaction of experiment **II** compare with that of experiment **III**? Choose from MORE THAN, LESS THAN or EQUAL TO. (1)
- 10.5.2 How will the activation energy of the reaction in experiment **I** compare with that of the reaction in experiment **III**? Choose from MORE THAN, LESS THAN or EQUAL TO. (1)
- 10.6 The rate of the reaction in experiment **III** is higher than that of experiment **I**. Fully explain this statement by referring to the collision theory. (3) [17]

QUESTION 11

Learners use the reaction between sodium thiosulphate and hydrochloric acid to investigate one of the factors that affects reaction rate. The balanced equation for the reaction is:

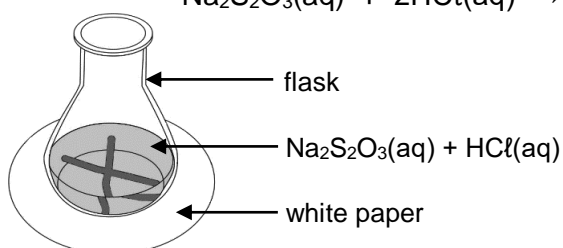
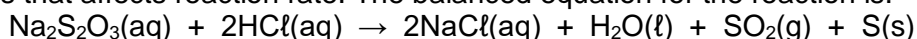

In the first experiment, 50 cm³ of the sodium thiosulphate solution is added to 100 cm³ of a 2 mol·dm⁻³ dilute hydrochloric acid solution in a flask that is placed over a cross drawn on a sheet of white paper. The hydrochloric acid is in EXCESS.

The time taken for the cross to become invisible, when viewed from the top, is recorded. The experiment is then repeated four times with different volumes of the sodium thiosulphate solution. The results obtained are shown in the table below.

EXPERIMENT	VOLUME OF $\text{Na}_2\text{S}_2\text{O}_3$ (cm^3)	VOLUME OF H_2O (cm^3)	TIME (s)	AVERAGE RATE ($\frac{1}{\text{time}}$) ($\times 10^{-2} \text{ s}^{-1}$)
1	50	0	22,7	4,4
2	40	10	28,6	3,5
3	30	20	38,5	2,6
4	20	30	58,8	1,7
5	10	40	111,1	0,9

- 11.1 Define *reaction rate*. (2)
- 11.2 How does the concentration of the sodium thiosulphate solution used in experiment **2** compare to that used in experiment **5**? Choose from MORE THAN, LESS THAN or EQUAL TO. (1)
- 11.3 Draw a graph of average reaction rate versus volume of sodium thiosulphate used on a GRAPH SHEET. (3)
- 11.4 Use the information in the graph to answer the following questions.
- 11.4.1 Determine the volume of dilute sodium thiosulphate solution that needs to react in order for the cross to become invisible in 40 seconds. USE DOTTED LINES ON THE GRAPH TO SHOW HOW YOU ARRIVED AT THE ANSWER. (3)
- 11.4.2 Write down a conclusion for this investigation. (2)
- 11.5 Use the collision theory to explain the effect of an increase in concentration on reaction rate. (3)
- 11.6 The mass of sulphur produced in experiment **1** is 1,62 g. Calculate the mass of the sodium thiosulphate used in experiment **1**. (4) **[18]**

QUESTION 12

Two experiments are carried out to investigate one of the factors that affects the reaction rate between magnesium and dilute hydrochloric acid. The reaction that takes place is represented by the following balanced equation:

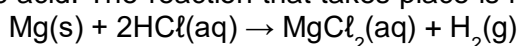

In **experiment 1** a certain mass of magnesium *ribbon* reacts with excess dilute hydrochloric acid. In **experiment 2** magnesium *powder* of the same mass as the magnesium ribbon, reacts with the same volume of excess dilute hydrochloric acid. The concentration of the acid is the same in both experiments. The apparatus below is used for the investigation.

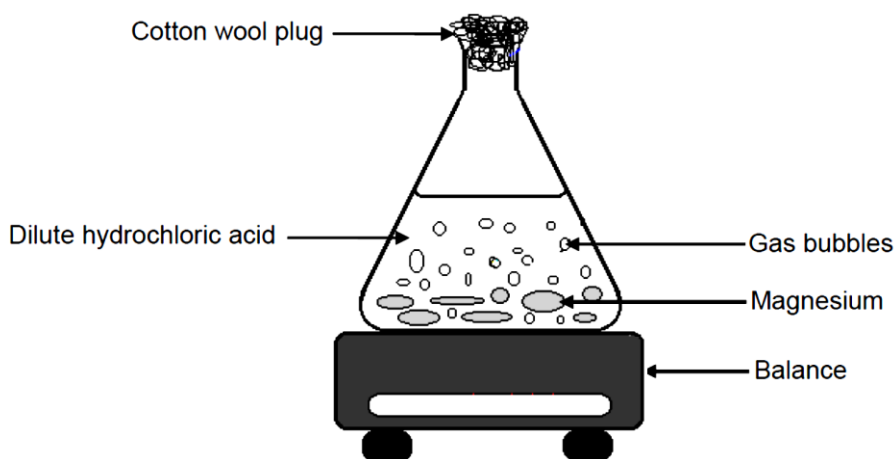

- 12.1 Define *reaction rate*. (2)

12.2 For this investigation, write down the:

12.2.1 Independent variable

(1)

12.2.2 Controlled variable

(1)

The change in mass of magnesium is calculated and recorded in 2-minute intervals for both experiments. The results obtained are shown in the graph below (NOT drawn to scale).

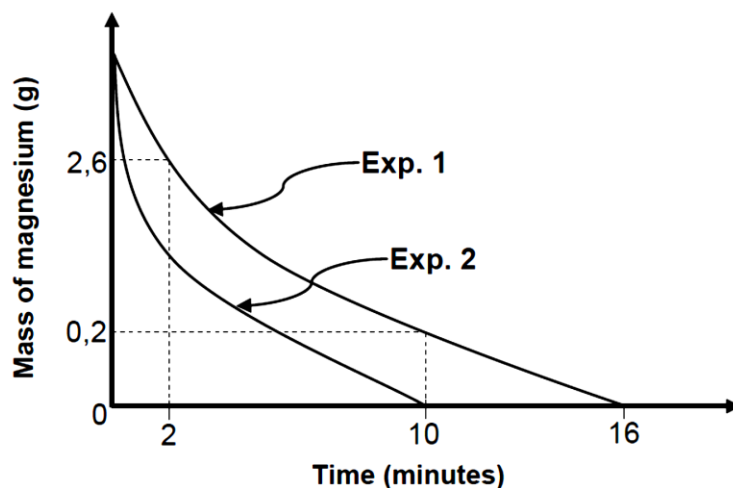

12.3 Use the information on the graph to:

12.3.1 Calculate the volume of hydrogen gas produced in **experiment 1** from $t = 2$ minutes to $t = 10$ minutes

Take the molar gas volume as $25 \text{ dm}^3 \cdot \text{mol}^{-1}$.

(5)

12.3.2 Calculate the initial mass of magnesium used if the average rate of formation of hydrogen gas in **experiment 2** was $2,08 \times 10^{-4} \text{ mol} \cdot \text{s}^{-1}$.

(5)

12.4 Use the collision theory to explain why the curve of **experiment 2** is steeper than that of **experiment 1**.

(3)

[17]

QUESTION 13

The reaction of zinc and EXCESS dilute hydrochloric acid is used to investigate factors that affect reaction rate. The balanced equation for the reaction is:

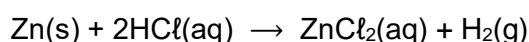

The reaction conditions used and the results obtained for each experiment are summarised in the table below. The same mass of zinc is used in all the experiments. The zinc is completely covered in all reactions. The reaction time is the time it takes the reaction to be completed.

EXPERIMENT	CONCENTRATION OF HCl (mol·dm ⁻³)	VOLUME OF HCl (cm ³)	STATE OF DIVISION OF Zn	TEMPERATURE OF HCl (°C)	REACTION TIME (min.)
1	2,0	200	powder	25	7
2	1,5	200	granules	25	14
3	5,0	200	powder	25	5
4	1,5	400	granules	25	x
5	2,0	200	powder	35	4

13.1 Experiment 1 and experiment 5 are compared. Write down the independent variable.

(1)

13.2 Define *reaction rate*.

(2)

13.3 Write down the value of x in experiment 4.

(2)

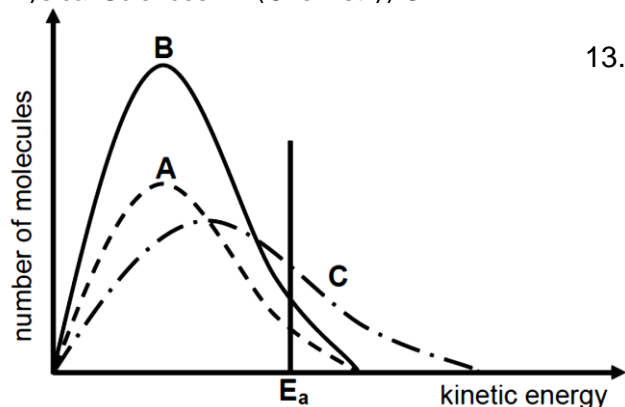

13.4 The Maxwell-Boltzmann energy distribution curves for particles in each of experiments 1, 3 and 5 are shown alongside.

Identify the graph (A or B or C) that represents the following:

13.4.1 Experiment 3
Give a reason for the answer. (2)

13.4.2 Experiment 5
Give a reason for the answer. (2)

13.5 Experiment 6 is now conducted using a catalyst and the SAME reaction conditions as for Experiment 1.

13.5.1 What is the function of the catalyst in this experiment? (1)

13.5.2 How will the heat of reaction in experiment 6 compare to that in experiment 1? Choose from: GREATER THAN, EQUAL TO or LESS THAN. (1)

13.6 Calculate the average rate of the reaction (in $\text{mol}\cdot\text{min}^{-1}$) with respect to zinc for experiment 2 if 1,5 g of zinc is used. (4) [15]

CHEMICAL EQUILIBRIUM

QUESTION 1

A certain amount of nitrogen dioxide gas (NO_2) is sealed in a gas syringe at 25°C . When equilibrium is reached, the volume occupied by the reaction mixture in the gas syringe is 80 cm^3 . The balanced chemical equation for the reaction taking place is:

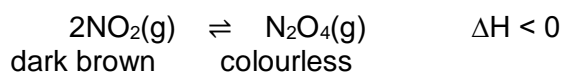

1.1 Define the term *chemical equilibrium*. (2)

1.2 At equilibrium the concentration of the $\text{NO}_2(\text{g})$ is $0,2\text{ mol}\cdot\text{dm}^{-3}$. The equilibrium constant for the reaction is 171 at 25°C . Calculate the initial number of moles of $\text{NO}_2(\text{g})$ placed in the gas syringe. (8)

1.3 The diagram shows the reaction mixture in the gas syringe after equilibrium is established. The pressure is now increased by decreasing the volume of the gas syringe at constant temperature as illustrated in the diagram below.



1.3.1 IMMEDIATELY after increasing the pressure, the colour of the reaction mixture in the gas syringe appears darker than before. Give a reason for this observation. (1)

After a while a new equilibrium is established as illustrated below. The colour of the reaction mixture in the gas syringe now appears lighter than the initial colour.



1.3.2 Use Le Chatelier's principle to explain the colour change observed in the gas syringe. (3)

1.4 The temperature of the reaction mixture in the gas syringe is now increased and a new equilibrium is established. How will each of the following be affected?

1.4.1 Colour of the reaction mixture
Write down only DARKER, LIGHTER or REMAINS THE SAME. (1)

1.4.2 Value of the equilibrium constant (K_c)
Write down only INCREASES, DECREASES or REMAINS THE SAME. (1)

[16]

QUESTION 2

Pure hydrogen iodide, sealed in a 2 dm³ container at 721 K, decomposes according to the following balanced equation: $2\text{HI}(\text{g}) \rightleftharpoons \text{H}_2(\text{g}) + \text{I}_2(\text{g})$ $\Delta H = +26 \text{ kJ}\cdot\text{mol}^{-1}$

The graph below shows how reaction rate changes with time for this reversible reaction.

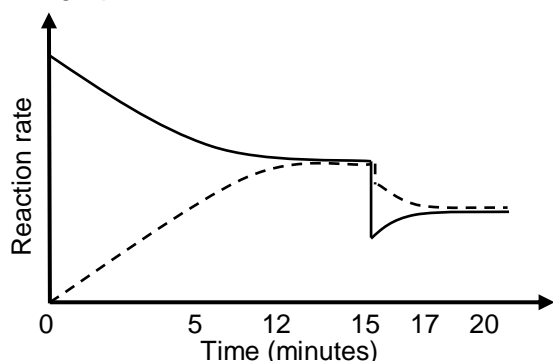

2.1 Write down the meaning of the term *reversible reaction*. (1)

2.2 How does the concentration of the reactant change between the 12th and the 15th minute? Write down only INCREASES, DECREASES or NO CHANGE. (1)

2.3 The rates of both the forward and the reverse reactions suddenly change at $t = 15$ minutes.

2.3.1 Give a reason for the sudden change in reaction rate. (1)

2.3.2 Fully explain how you arrived at the answer to QUESTION 2.3.1. (3)

The equilibrium constant (K_c) for the forward reaction is 0,02 at 721 K.

2.4 At equilibrium it is found that 0,04 mol HI(g) is present in the container. Calculate the concentration of H₂(g) at equilibrium. (6)

2.5 Calculate the equilibrium constant for the reverse reaction. (1)

2.6 The temperature is now increased to 800 K. How will the value of the equilibrium constant (K_c) for the forward reaction change? Write down only INCREASES, DECREASES or REMAINS THE SAME. (1) [14]

QUESTION 3

Initially excess NH₄HS(s) is placed in a 5 dm³ container at 218 °C. The container is sealed and the reaction is allowed to reach equilibrium according to the following balanced equation:

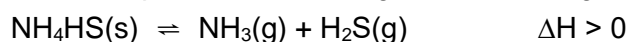

3.1 State Le Chatelier's principle. (2)

3.2 What effect will each of the following changes have on the amount of NH₃(g) at equilibrium? Write down only INCREASES, DECREASES or REMAINS THE SAME.

3.2.1 More NH₄HS(s) is added (1)

3.2.2 The temperature is increased (1)

3.3 The equilibrium constant for this reaction at 218 °C is $1,2 \times 10^{-4}$. Calculate the minimum mass of NH₄HS(s) that must be sealed in the container to obtain equilibrium. (6)

The pressure in the container is now increased by decreasing the volume of the container at constant temperature.

3.4 How will this change affect the number of moles of H₂S(g) produced? Fully explain the answer. (3) [14]

QUESTION 4

An unknown gas, $X_2(g)$, is sealed in a container and allowed to form $X_3(g)$ at $300\text{ }^\circ\text{C}$. The reaction reaches equilibrium according to the following balanced equation: $3X_2(g) \rightleftharpoons 2X_3(g)$

- 4.1 How will the rate of formation of $X_3(g)$ compare to the rate of formation of $X_2(g)$ at equilibrium? Write down only HIGHER THAN, LOWER THAN or EQUAL TO. (1)

The reaction mixture is analysed at regular time intervals. The results obtained are shown in the table below.

TIME (s)	[X_2] (mol·dm ⁻³)	[X_3] (mol·dm ⁻³)
0	0,4	0
2	0,22	0,120
4	0,08	0,213
6	0,06	0,226
8	0,06	0,226
10	0,06	0,226

- 4.2 Calculate the equilibrium constant, K_c , for this reaction at $300\text{ }^\circ\text{C}$. (4)

- 4.3 More $X_3(g)$ is now added to the container.

- 4.3.1 How will this change affect the amount of $X_2(g)$? Write down INCREASES, DECREASES or REMAINS THE SAME. (1)

- 4.3.2 Use Le Chatelier's principle to explain the answer to QUESTION 4.3.1. (2)

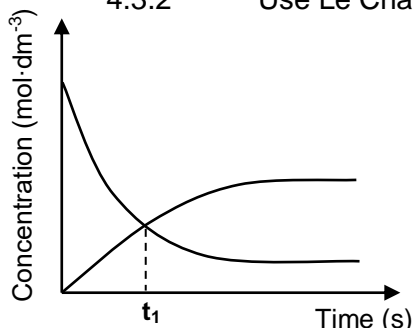

The curves on the set of axes alongside (not drawn to scale) was obtained from the results in the table.

- 4.4 How does the rate of the forward reaction compare to that of the reverse reaction at t_1 ? Write down only HIGHER THAN, LOWER THAN or EQUAL TO. (1)

The reaction is now repeated at a temperature of $400\text{ }^\circ\text{C}$. The curves indicated by the dotted lines below were obtained at this temperature.

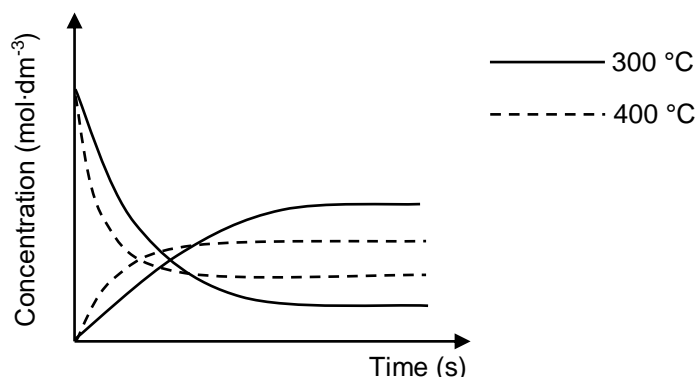

- 4.5 Is the forward reaction EXOTHERMIC or ENDOTHERMIC? Fully explain how you arrived at the answer. (4)

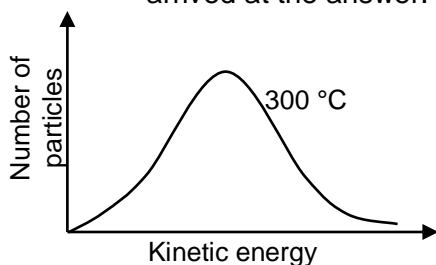

The Maxwell-Boltzmann distribution curve represents the number of particles against kinetic energy at $300\text{ }^\circ\text{C}$.

- 4.6 Redraw this curve in the ANSWER BOOK. On the same set of axes, sketch the curve that will be obtained at $400\text{ }^\circ\text{C}$. Clearly label the curves as $300\text{ }^\circ\text{C}$ and $400\text{ }^\circ\text{C}$ respectively. (2) [15]

QUESTION 5

Initially, 2,2 g of pure CO₂(g) is sealed in an empty 5 dm³ container at 900 °C.

- 5.1 Calculate the initial concentration of CO₂(g). (4)
 5.2 Give a reason why equilibrium will not be established. (1)

CaCO₃(s) is now added to the 2,2 g CO₂(g) in the container and after a while equilibrium is established at 900 °C according to the following balanced equation:



The equilibrium constant for this reaction at 900 °C is 0,0108.

- 5.3 Give a reason why this reaction will only reach equilibrium in a SEALED container. (1)
 5.4 Calculate the minimum mass of CaCO₃(s) that must be added to the container to achieve equilibrium. (7)
 5.5 How will EACH of the following changes affect the amount of CO₂(g)? Write down only INCREASES, DECREASES or REMAINS THE SAME.
 5.5.1 More CaCO₃(s) is added at 900 °C (1)
 5.5.2 The pressure is increased (1)
 5.6 It is found that the equilibrium constant (K_c) for this reaction is 2,6 x 10⁻⁶ at 727 °C. Is the reaction EXOTHERMIC or ENDOTHERMIC? Fully explain how you arrived at the answer. (4)

[19]**QUESTION 6**

Carbon dioxide reacts with carbon in a closed system to produce carbon monoxide, CO(g), according to the following balanced equation:



- 6.1 What does the double arrow indicate in the equation above? (1)
 6.2 Is the above reaction an EXOTHERMIC reaction or an ENDOTHERMIC reaction? Give a reason for the answer. (2)

Initially an unknown amount of carbon dioxide is exposed to hot carbon at 800 °C in a sealed 2 dm³ container. The equilibrium constant, K_c, for the reaction at this temperature is 14. At equilibrium it is found that 168,00 g carbon monoxide is present.

- 6.3 How will the equilibrium concentration of the product compare to that of the reactants? Choose from LARGER THAN, SMALLER THAN or EQUAL TO. Give a reason for the answer. (No calculation is required.) (2)
 6.4 Calculate the initial amount (in moles) of CO₂(g) present. (9)
 6.5 State how EACH of the following will affect the yield of CO(g) at equilibrium. Choose from INCREASES, DECREASES or REMAINS THE SAME.
 6.5.1 More carbon is added at constant temperature. (1)
 6.5.2 The pressure is increased. (1)
 6.5.3 The temperature is increased. (1)

[17]**QUESTION 7**

Hydrogen gas, H₂(g), reacts with sulphur powder, S(s), according to the following balanced equation: H₂(g) + S(s) ⇌ H₂S(g) ΔH < 0

The system reaches equilibrium at 90 °C.

- 7.1 Define the term *chemical equilibrium*. (2)
 7.2 How will EACH of the following changes affect the number of moles of H₂S(g) at equilibrium? Choose from INCREASES, DECREASES or REMAINS THE SAME.
 7.2.1 The addition of more sulphur (1)

- 7.2.2 An increase in temperature
Use Le Chatelier's principle to explain the answer. (4)

- 7.3 The sketch graph below was obtained for the equilibrium mixture. (2)

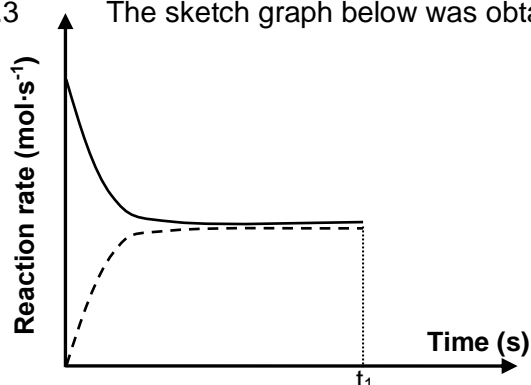

A catalyst is added to the equilibrium mixture at time t_1 .

Redraw the graph in your book. On the same set of axes, complete the graph showing the effect of the catalyst on the reaction rates. (2)

Initially 0,16 mol $\text{H}_2(\text{g})$ and excess $\text{S}(\text{s})$ are sealed in a 2 dm^3 container and the system is allowed to reach equilibrium at $90 \text{ }^\circ\text{C}$.

An exact amount of $\text{Pb}(\text{NO}_3)_2$ solution is now added to the container so that ALL the $\text{H}_2\text{S}(\text{g})$ present in the container at EQUILIBRIUM is converted to $\text{PbS}(\text{s})$ according to the following balanced equation: $\text{Pb}(\text{NO}_3)_2(\text{aq}) + \text{H}_2\text{S}(\text{g}) \rightarrow \text{PbS}(\text{s}) + 2\text{HNO}_3(\text{aq})$

The mass of the PbS precipitate is 2,39 g.

- 7.4 Calculate the equilibrium constant K_c for the reaction $\text{H}_2(\text{g}) + \text{S}(\text{s}) \rightleftharpoons \text{H}_2\text{S}(\text{g})$ at $90 \text{ }^\circ\text{C}$. (9)

[18]

QUESTION 8

- 8.1 Consider the balanced equation for a reversible reaction below.

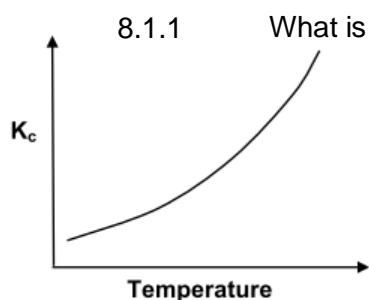
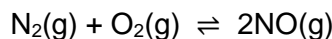

The sketch graph alongside shows the relationship between the value of the equilibrium constant (K_c) for this reaction and temperature.

- 8.1.2 Is the reaction ENDOTHERMIC or EXOTHERMIC? (1)

- 8.1.3 Fully explain the answer to QUESTION 8.1.2. (3)

How will EACH of the following changes affect the amount of $\text{NO}(\text{g})$ at equilibrium? Choose from INCREASES, DECREASES or REMAINS THE SAME.

- 8.1.4 More $\text{N}_2(\text{g})$ is added. (1)

- 8.1.5 The pressure is increased by decreasing the volume. (1)

- 8.2 Initially 336 g titanium (Ti) and 426 g chlorine gas (Cl_2) are mixed in a sealed 2 dm^3 container at a certain temperature. The reaction reaches equilibrium according to the following balanced equation: $\text{Ti}(\text{s}) + 2\text{Cl}_2(\text{g}) \rightleftharpoons \text{TiCl}_4(\text{s})$

At equilibrium it is found that 288 g titanium is left in the container.

- 8.2.1 Calculate the equilibrium constant (K_c) for the reaction at this temperature. (8)

- 8.2.2 More titanium is now added to the equilibrium mixture. How will this change affect the yield of $\text{TiCl}_4(\text{s})$? Choose from INCREASES, DECREASES or REMAINS THE SAME. (1)

[16]

QUESTION 9

Hydrogen and iodine are sealed in a 2 dm^3 container. The reaction is allowed to reach equilibrium at 700 K according to the following balanced equation: $\text{H}_2(\text{g}) + \text{I}_2(\text{g}) \rightleftharpoons 2\text{HI}(\text{g})$

- 9.1 Give a reason why changes in pressure will have no effect on the equilibrium position. (1)

- 9.2 At equilibrium, 0,028 mol $\text{H}_2(\text{g})$ and 0,017 mol $\text{I}_2(\text{g})$ are present in the container. Calculate the initial mass of $\text{I}_2(\text{g})$, in grams, that was sealed in the container, if K_c for the reaction is 55,3 at 700 K. (9)

The reaction rate versus time graph below represents different changes made to the equilibrium mixture.

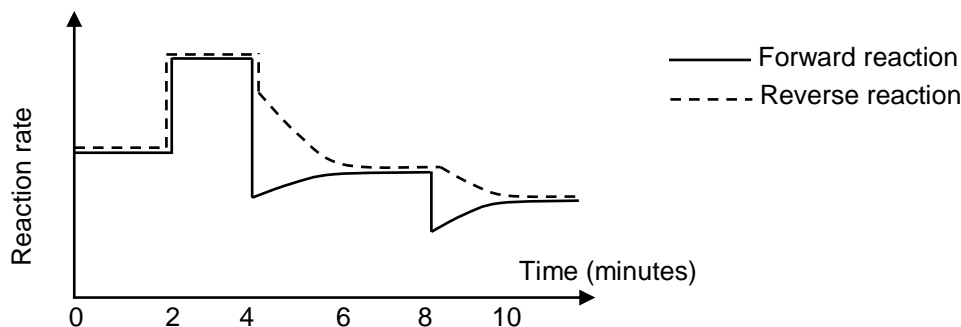

- 9.3 What do the parallel lines in the first two minutes indicate? (1)
- 9.4 State TWO possible changes that could be made to the reaction conditions at $t = 2$ minutes. (2)
- 9.5 The temperature of the equilibrium mixture was changed at $t = 4$ minutes.
- 9.5.1 Is the forward reaction EXOTHERMIC or ENDOTHERMIC? Fully explain the answer. (3)
- 9.5.2 How will this change influence the K_c value? Choose from INCREASES, DECREASES or REMAINS THE SAME. (1)
- 9.6 What change was made to the equilibrium mixture at $t = 8$ minutes? (1)

[18]

QUESTION 10

Carbonyl bromide, COBr_2 , decomposes into carbon monoxide and bromine according to the following balanced equation: $\text{COBr}_2(\text{g}) \rightleftharpoons \text{CO}(\text{g}) + \text{Br}_2(\text{g}) \quad \Delta H > 0$

Initially $\text{COBr}_2(\text{g})$ is sealed in a 2 dm^3 container and heated to $73 \text{ }^\circ\text{C}$. The reaction is allowed to reach equilibrium at this temperature. The equilibrium constant for the reaction at this temperature is 0,19.

- 10.1 Define *chemical equilibrium*. (2)
- At equilibrium it is found that 1,12 g $\text{CO}(\text{g})$ is present in the container.
- 10.2 Calculate the equilibrium concentration of the $\text{COBr}_2(\text{g})$. (7)
- 10.3 Calculate the percentage of $\text{COBr}_2(\text{g})$ that decomposed at $73 \text{ }^\circ\text{C}$. (4)
- 10.4 Which ONE of the following CORRECTLY describes the K_c value when equilibrium is reached at a lower temperature? (1)

$K_c < 0,19$	$K_c > 0,19$	$K_c = 0,19$
--------------	--------------	--------------

- 10.5 The pressure of the system is now decreased by increasing the volume of the container at $73 \text{ }^\circ\text{C}$ and the system is allowed to reach equilibrium. How will the number of moles of $\text{COBr}_2(\text{g})$ be affected? Choose from INCREASES, DECREASES or REMAINS THE SAME. Explain the answer. (3)

[17]

QUESTION 11

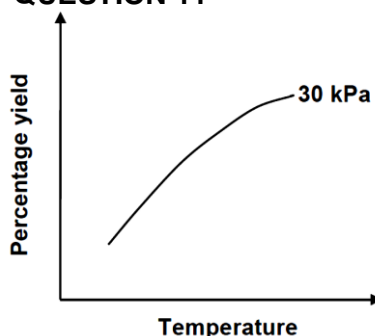

- 11.1 A reversible gaseous reaction is allowed to reach equilibrium in a closed container at different temperatures and pressures. The graph shows the percentage yield for this reaction at 30 kPa as the temperature is increased.

Use the information in the graph above to answer the following questions

- 11.1.1 State Le Chatelier's principle. (2)

- 11.1.2 The heat of reaction (ΔH) for the forward reaction is POSITIVE. Use Le Chatelier's principle to explain this statement. (3)

The graph below show the percentage yield for this reaction as pressure changes at constant temperature.

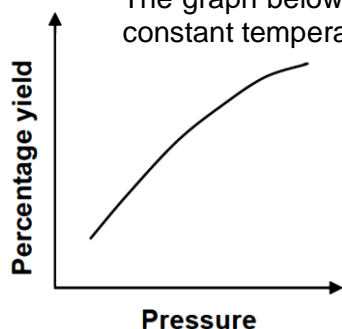

- 11.1.3 Explain the effect of an increase in pressure on the equilibrium position of a reaction. (2)

- 11.1.4 Which ONE of the following equations (I, II or III) represents the equilibrium above?

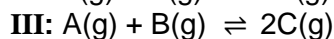
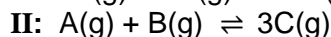

- 11.2 A mixture of 0,2 moles of hydrogen chloride (HCl) and 0,11 moles of oxygen gas (O_2) is sealed in a 200 cm^3 flask at a certain temperature. The reaction reaches equilibrium according to the balanced equation: $4HCl(g) + O_2(g) \rightleftharpoons 2Cl_2(g) + 2H_2O(g)$

It is found that 1,825 g of hydrogen chloride is present at equilibrium. Calculate the equilibrium constant, K_c , for this reaction at this temperature. (9) [18]

QUESTION 12

The equation below represents a hypothetical reaction that reaches equilibrium in a closed container after 2 minutes at room temperature. The letters **x**, **y** and **z** represent the number of moles in the balanced equation.

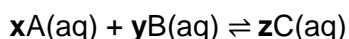

The graph below shows the change in the number of moles of reactants and products versus time during the reaction.

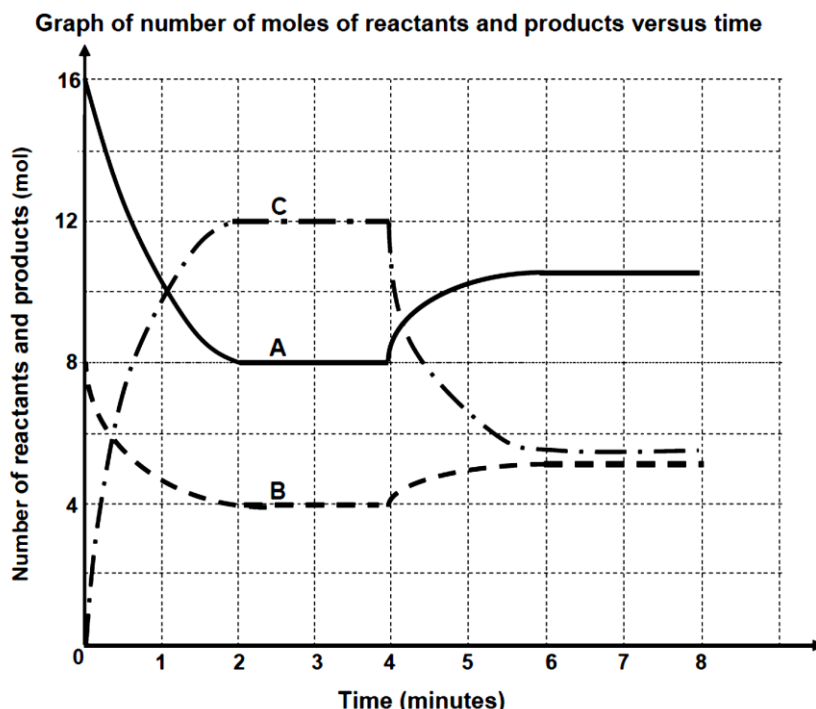

- 12.1 Define a *dynamic equilibrium*. (2)
- 12.2 Use the information in the graph and write down the value of:
- 12.2.1 **x** (1)
- 12.2.2 **y** (1)
- 12.2.2 **z** (1)
- 12.3 Calculate the equilibrium constant, K_c , for this hypothetical reaction at room temperature if the volume of the closed container is 3 dm^3 . (7)

- 12.4 At $t = 4$ minutes, the temperature of the system was increased to $60\text{ }^\circ\text{C}$. Is the REVERSE reaction EXOTHERMIC or ENDOTHERMIC? Explain how you arrived at the answer. (3)

[15]

QUESTION 13

Dinitrogen tetraoxide, $\text{N}_2\text{O}_4(\text{g})$, decomposes to nitrogen dioxide, $\text{NO}_2(\text{g})$, in a sealed syringe of volume 2 dm^3 .



The mixture reaches equilibrium at $325\text{ }^\circ\text{C}$ according to the following balanced equation:

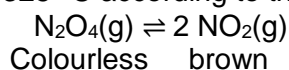

When equilibrium is reached, it is observed that the colour of the gas in the syringe is brown.

- 13.1 State Le Chatelier's principle. (2)
- 13.2 The syringe is now dipped into a beaker of ice water. After a while the brown colour disappears. Is the forward reaction EXOTHERMIC or ENDOTHERMIC? Explain the answer using Le Chatelier's principle. (3)
- 13.3 The volume of the syringe is now decreased while the temperature is kept constant. How will EACH of the following be affected? Choose from: INCREASES, DECREASES or REMAINS THE SAME. (3)
- 13.3.1 The number of moles of $\text{N}_2\text{O}_4(\text{g})$ (1)
- 13.3.2 The value of the equilibrium constant (1)
- 13.3.2 The rate of the forward and reverse reactions (1)
- 13.4 Initially **X** moles of $\text{N}_2\text{O}_4(\text{g})$ were placed in the syringe of volume 2 dm^3 . When equilibrium was reached, it was found that 20% of the $\text{N}_2\text{O}_4(\text{g})$ had decomposed. If the equilibrium constant, K_c , for the reaction is 0,16 at $325\text{ }^\circ\text{C}$, calculate the value of **X**. (8)

ACIDS AND BASES**QUESTION 1**

- 1.1 Nitric acid (HNO_3), an important acid used in industry, is a strong acid.
- 1.1.1 Give a reason why nitric acid is classified as a strong acid. (1)
- 1.1.2 Write down the NAME or FORMULA of the conjugate base of nitric acid. (1)
- 1.1.3 Calculate the pH of a $0,3\text{ mol}\cdot\text{dm}^{-3}$ nitric acid solution. (3)
- 1.2 A laboratory technician wants to determine the percentage purity of magnesium oxide. He dissolves a $4,5\text{ g}$ sample of the magnesium oxide in 100 cm^3 hydrochloric acid of concentration $2\text{ mol}\cdot\text{dm}^{-3}$.
- 1.2.1 Calculate the number of moles of hydrochloric acid added to the magnesium oxide. (3)

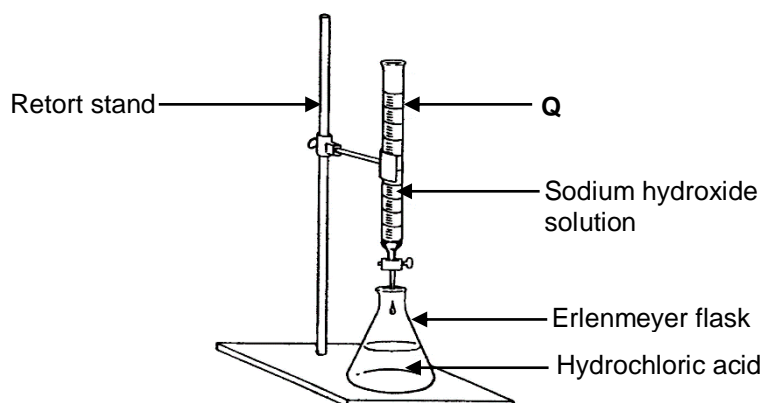

He then uses the apparatus below to titrate the EXCESS hydrochloric acid in the above solution against a sodium hydroxide solution.

- 1.2.2 Write down the name of apparatus **Q** in the above diagram. (1)

1.2.3 The following indicators are available for the titration:

INDICATOR	pH RANGE
A	3,1 – 4,4
B	6,0 – 7,6
C	8,3 – 10,0

Which ONE of the above indicators (**A**, **B** or **C**) is most suitable to indicate the exact endpoint in this titration? Give a reason for the answer. (3)

1.2.4 During the titration, the technician uses distilled water to wash any sodium hydroxide spilled against the sides of the Erlenmeyer flask into the solution. Give a reason why the addition of distilled water to the Erlenmeyer flask will not influence the results. (1)

1.2.5 At the endpoint of the titration he finds that 21 cm³ of a 0,2 mol dm⁻³ sodium hydroxide solution has neutralised the EXCESS hydrochloric acid. Calculate the number of moles of hydrochloric acid in excess. (3)

1.2.6 The balanced equation for the reaction between hydrochloric acid and magnesium oxide is: $\text{MgO(s)} + 2\text{HCl(aq)} \rightarrow \text{MgCl}_2\text{(aq)} + \text{H}_2\text{O(l)}$
Calculate the percentage purity of the magnesium oxide. Assume that only the magnesium oxide in the 4,5 g sample reacted with the acid. (5) **[21]**

QUESTION 2

2.1 Sulphuric acid is a diprotic acid.

2.1.1 Define an *acid* in terms of the Lowry-Brønsted theory. (2)

2.1.2 Give a reason why sulphuric acid is referred to as a *diprotic acid*. (1)

2.2 The hydrogen carbonate ion can act as both an acid and a base. It reacts with water according to the following balanced equation:

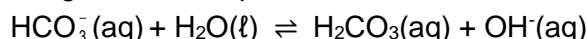

2.2.1 Write down ONE word for the underlined phrase. (1)

2.2.2 $\text{HCO}_3^-(\text{aq})$ acts as base in the above reaction. Write down the formula of the conjugate acid of $\text{HCO}_3^-(\text{aq})$. (1)

2.3 A learner accidentally spills some sulphuric acid of concentration 6 mol·dm⁻³ from a flask on the laboratory bench. Her teacher tells her to neutralise the spilled acid by sprinkling sodium hydrogen carbonate powder onto it. The reaction that takes place is: (Assume that the H_2SO_4 ionises completely.)



The fizzing, due to the formation of carbon dioxide, stops after the learner has added 27 g sodium hydrogen carbonate to the spilled acid.

2.3.1 Calculate the volume of sulphuric acid that spilled. Assume that all the sodium hydrogen carbonate reacts with all the acid. (6)

The learner now dilutes some of the 6 mol·dm⁻³ sulphuric acid solution in the flask to 0,1 mol·dm⁻³.

2.3.2 Calculate the volume of the 6 mol·dm⁻³ sulphuric acid solution needed to prepare 1 dm³ of the dilute acid. (2)

During a titration 25 cm³ of the 0,1 mol·dm⁻³ sulphuric acid solution is added to an Erlenmeyer flask and titrated with a 0,1 mol·dm⁻³ sodium hydroxide solution.

2.3.3 The learner uses bromothymol blue as indicator. What is the purpose of this indicator? (1)

- 2.3.4 Calculate the pH of the solution in the flask after the addition of 30 cm³ of sodium hydroxide. The endpoint of the titration is not yet reached at this point. (8)
[22]

QUESTION 3

Anhydrous oxalic acid is an example of an acid that can donate two protons and thus ionises in two steps as represented by the equations below:

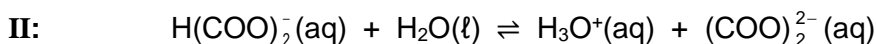
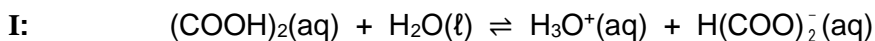

3.1 Write down:

3.1.1 ONE word for the underlined phrase in the above sentence (1)

3.1.2 The FORMULA of each of the TWO bases in **reaction II** (2)

3.1.3 The FORMULA of the substance that acts as ampholyte in **reactions I and II**. Give a reason for the answer. (2)

3.2 Give a reason why oxalic acid is a weak acid. (1)

3.3 A standard solution of (COOH)₂ of concentration 0,20 mol·dm⁻³ is prepared by dissolving a certain amount of (COOH)₂ in water in a 250 cm³ volumetric flask. Calculate the mass of (COOH)₂ needed to prepare the standard solution. (4)

3.4 During a titration 25 cm³ of the standard solution of (COOH)₂ prepared in QUESTION 7.3 is neutralised by a sodium hydroxide solution from a burette. The balanced equation for the reaction is:

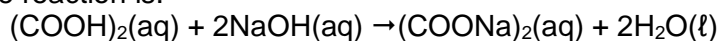

The diagrams below show the burette readings before the titration commenced and at the endpoint respectively.

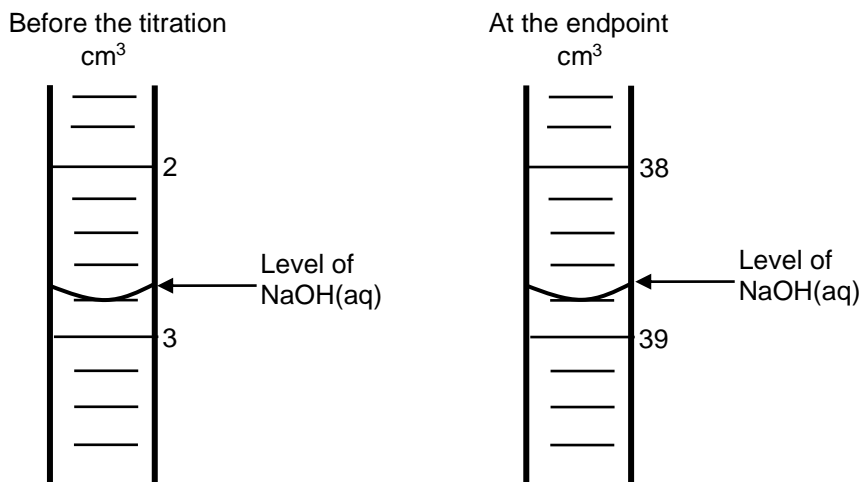

3.4.1 Use the burette readings and calculate the concentration of the sodium hydroxide solution. (5)

3.4.2 Write down a balanced equation that explains why the solution has a pH greater than 7 at the endpoint. (3)
[18]

QUESTION 4

4.1 Ammonium chloride crystals, NH₄Cl(s), dissolve in water to form ammonium and chloride ions. The ammonium ions react with water according to the following balanced equation: $\text{NH}_4^+(\text{aq}) + \text{H}_2\text{O}(\ell) \rightleftharpoons \text{NH}_3(\text{aq}) + \text{H}_3\text{O}^+(\text{aq})$

4.1.1 Write down the name of the process described by the underlined sentence. (1)

- 4.1.2 Is ammonium chloride ACIDIC or BASIC in aqueous solution? Give a reason for the answer. (2)
- 4.2 A certain fertiliser consists of 92% ammonium chloride. A sample of mass x g of this fertiliser is dissolved in 100 cm^3 of a $0,10 \text{ mol}\cdot\text{dm}^{-3}$ sodium hydroxide solution, $\text{NaOH}(\text{aq})$. The NaOH is in excess. The balanced equation for the reaction is:
- $$\text{NH}_4\text{Cl}(\text{s}) + \text{NaOH}(\text{aq}) \rightarrow \text{NH}_3(\text{g}) + \text{H}_2\text{O}(\text{l}) + \text{NaCl}(\text{aq})$$
- 4.2.1 Calculate the number of moles of sodium hydroxide in which the sample is dissolved. (3)
- During a titration, 25 cm^3 of the excess sodium hydroxide solution is titrated with a $0,11 \text{ mol}\cdot\text{dm}^{-3}$ hydrochloric acid solution, $\text{HCl}(\text{aq})$. At the endpoint it is found that $14,55 \text{ cm}^3$ of the hydrochloric acid was used to neutralise the sodium hydroxide solution according to the following balanced equation:
- $$\text{HCl}(\text{aq}) + \text{NaOH}(\text{aq}) \rightarrow \text{NaCl}(\text{aq}) + \text{H}_2\text{O}(\text{l})$$
- 4.2.2 Calculate the mass x (in grams) of the fertiliser sample used. (8)
- 4.3 Calculate the pH of a $0,5 \text{ mol}\cdot\text{dm}^{-3}$ sodium hydroxide solution at $25 \text{ }^\circ\text{C}$. (4)

[18]**QUESTION 5**

- 5.1 Define an *acid* in terms of the Lowry-Brønsted theory. (2)
- 5.2 Carbonated water is an aqueous solution of carbonic acid, H_2CO_3 . $\text{H}_2\text{CO}_3(\text{aq})$ ionises in two steps when it dissolves in water.
- 5.2.1 Write down the FORMULA of the conjugate base of $\text{H}_2\text{CO}_3(\text{aq})$. (1)
- 5.2.2 Write down a balanced equation for the first step in the ionisation of carbonic acid. (3)
- 5.2.3 The pH of a carbonic acid solution at $25 \text{ }^\circ\text{C}$ is 3,4. Calculate the hydroxide ion concentration in the solution. (5)
- 5.3 **X** is a monoprotic acid.
- 5.3.1 State the meaning of the term *monoprotic*. (1)
- 5.3.2 A sample of acid **X** is titrated with a standard sodium hydroxide solution using a suitable indicator. At the endpoint it is found that 25 cm^3 of acid **X** is neutralised by $27,5 \text{ cm}^3$ of the sodium hydroxide solution of concentration $0,1 \text{ mol}\cdot\text{dm}^{-3}$. Calculate the concentration of acid **X**. (5)
- 5.3.3 The concentration of H_3O^+ ions in the sample of acid **X** is $2,4 \times 10^{-4} \text{ mol}\cdot\text{dm}^{-3}$. Is acid **X** a WEAK or a STRONG acid? Explain the answer by referring to the answer in QUESTION 5.3.2. (3)

[20]**QUESTION 6**

- 6.1 Hydrogen carbonate ions react with water according to the following balanced equation: $\text{HCO}_3^-(\text{aq}) + \text{H}_2\text{O}(\text{l}) \rightleftharpoons \text{H}_2\text{CO}_3(\text{aq}) + \text{OH}^-(\text{aq})$
- 6.1.1 Define an *acid* according to the Lowry-Brønsted theory. (2)
- 6.1.2 Write down the FORMULAE of the two acids in the equation above. (2)
- 6.1.3 Write down the formula of a substance in the reaction above that can act as an ampholyte. (1)
- 6.2 During an experiment $0,50 \text{ dm}^3$ of a $0,10 \text{ mol}\cdot\text{dm}^{-3}$ HCl solution is added to $0,80 \text{ dm}^3$ of a NaHCO_3 solution of concentration $0,25 \text{ mol}\cdot\text{dm}^{-3}$. The balanced equation for the reaction is: $\text{NaHCO}_3(\text{aq}) + \text{HCl}(\text{aq}) \rightarrow \text{NaCl}(\text{aq}) + \text{CO}_2(\text{g}) + \text{H}_2\text{O}(\text{l})$
- 6.2.1 Calculate the concentration of the hydroxide ions in the solution on completion of the reaction. (8)
- 6.2.2 Calculate the pH of the solution on completion of the reaction. (4)

[17]

QUESTION 7

- 7.1 A learner dissolves ammonium chloride (NH_4Cl) crystals in water and measures the pH of the solution.
- 7.1.1 Define the term *hydrolysis* of a salt. (2)
- 7.1.2 Will the pH of the solution be GREATER THAN, SMALLER THAN or EQUAL TO 7? Write a relevant equation to support your answer. (3)
- 7.2 A sulphuric acid solution is prepared by dissolving 7,35 g of $\text{H}_2\text{SO}_4(\ell)$ in 500 cm^3 of water.
- 7.2.1 Calculate the number of moles of H_2SO_4 present in this solution. (2)
- Sodium hydroxide (NaOH) pellets are added to the 500 cm^3 H_2SO_4 solution. The balanced equation for the reaction is:
- $$\text{H}_2\text{SO}_4(\text{aq}) + 2\text{NaOH}(\text{s}) \rightarrow \text{Na}_2\text{SO}_4(\text{aq}) + 2\text{H}_2\text{O}(\ell)$$
- After completion of the reaction, the pH of the solution was found to be 1,3. Assume complete ionisation of H_2SO_4 .
- 7.2.2 Calculate the mass of NaOH added to the H_2SO_4 solution. Assume that the volume of the solution does not change. (9)

[16]**QUESTION 8**

- 8.1 Ethanoic acid (CH_3COOH) is an acid that ionises incompletely in water according to the following balanced equation:
- $$\text{CH}_3\text{COOH}(\text{aq}) + \text{H}_2\text{O}(\ell) \rightarrow \text{CH}_3\text{COO}^-(\text{aq}) + \text{H}_3\text{O}^+(\text{aq})$$
- 8.1.1 Write down the term used for the underlined phrase above. (1)
- 8.1.2 An ethanoic acid solution has a pH of 4 at 25°C. Calculate the concentration of the hydronium ions, $\text{H}_3\text{O}^+(\text{aq})$ in the solution. (3)
- 8.2 A standard solution of potassium hydroxide (KOH) is prepared in a 250 cm^3 volumetric flask. During a titration, 12,5 cm^3 of this solution neutralises 25 cm^3 of a 0,16 $\text{mol}\cdot\text{dm}^{-3}$ ethanoic acid solution. The balanced equation for the reaction is:
- $$\text{CH}_3\text{COOH}(\text{aq}) + \text{KOH}(\text{aq}) \rightarrow \text{CH}_3\text{COOK}(\text{aq}) + \text{H}_2\text{O}(\ell)$$
- 8.2.1 Define a base according to the Arrhenius theory. (2)
- 8.2.2 Calculate the mass of potassium hydroxide used to prepare the solution above in the 250 cm^3 volumetric flask. (7)
- 8.2.3 Will the pH of the solution in the conical flask at the end point be GREATER THAN 7, SMALLER THAN 7 or EQUAL TO 7? (1)
- 8.2.4 Explain the answer to QUESTION 8.2.3 with the aid of a balanced chemical equation. (3)

[17]**QUESTION 9**

The K_a values for two weak acids, oxalic acid and carbonic acid, are as follows:

NAME	FORMULA	K_a
Oxalic acid	$(\text{COOH})_2$	$5,6 \times 10^{-2}$
Carbonic acid	H_2CO_3	$4,3 \times 10^{-7}$

- 9.1 Define the term *weak acid*. (2)
- 9.2 Which acid, OXALIC ACID or CARBONIC ACID, is stronger? Give a reason for the answer. (2)
- 9.3 Oxalic acid ionises in water according to the following balanced equation:
- $$(\text{COOH})_2(\text{s}) + 2\text{H}_2\text{O}(\ell) \rightleftharpoons (\text{COO})_2^{2-}(\text{aq}) + 2\text{H}_3\text{O}^+(\text{aq})$$
- Write down the FORMULAE of the TWO bases in this equation. (2)

9.4 Learners prepare 2 dm³ of a sodium hydroxide solution of concentration 0,1 mol·dm⁻³. Calculate the pH of the solution. (4)

9.5 During a titration of the sodium hydroxide solution in QUESTION 9.4 with dilute oxalic acid, the learners find that 25,1 cm³ of the NaOH(aq) neutralises exactly 14,2 cm³ of the (COOH)₂(aq). The balanced equation for the reaction is as follows:

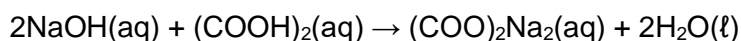

9.5.1 Calculate the concentration of the oxalic acid solution. (5)

The following indicators are available for the titration:

INDICATOR	pH RANGE
A	3,1–4,4
B	6,0–7,6
C	8,3–10,0

9.5.2 Which ONE of the indicators above is most suitable for this titration? Give a reason for the answer. (2) [17]

QUESTION 10

10.1 Ammonia ionises in water to form a basic solution according to the following balanced equation: $\text{NH}_3(\text{aq}) + \text{H}_2\text{O}(\ell) \rightleftharpoons \text{NH}_4^+(\text{aq}) + \text{OH}^-(\text{aq})$

10.1.1 Is ammonia a WEAK or a STRONG base? Give a reason for the answer. (2)

10.1.2 Write down the conjugate acid of NH₃(g). (1)

10.1.3 Identify ONE substance in this reaction that can behave as an ampholyte in some reactions. (1)

10.2 A learner adds distilled water to a soil sample and then filters the mixture. The pH of the filtered liquid is then measured. He then gradually adds an ammonia solution, NH₃(aq), to this liquid and measures the pH of the solution at regular intervals. The graph below shows the results obtained.

Graph of pH versus volume of NH₃(aq)

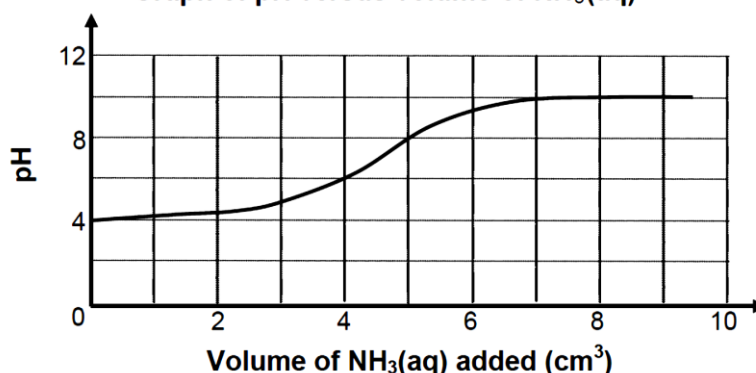

10.2.1 Is the soil sample ACIDIC or BASIC? Refer to the graph above and give a reason for the answer. (2)

10.2.2 Calculate the concentration of the hydroxide ions (OH⁻) in the reaction mixture after the addition of 4 cm³ of NH₃(aq). (4)

10.3 A laboratory technician wants to determine the concentration of a hydrochloric acid (HCl) sample. He adds 5 cm³ of the HCl sample to 495 cm³ of distilled water to give 500 cm³ of dilute hydrochloric acid, HCl(aq). During a reaction 50 cm³ of this dilute hydrochloric acid solution, HCl(aq), reacts completely with 0,29 g of sodium carbonate, Na₂CO₃(s).

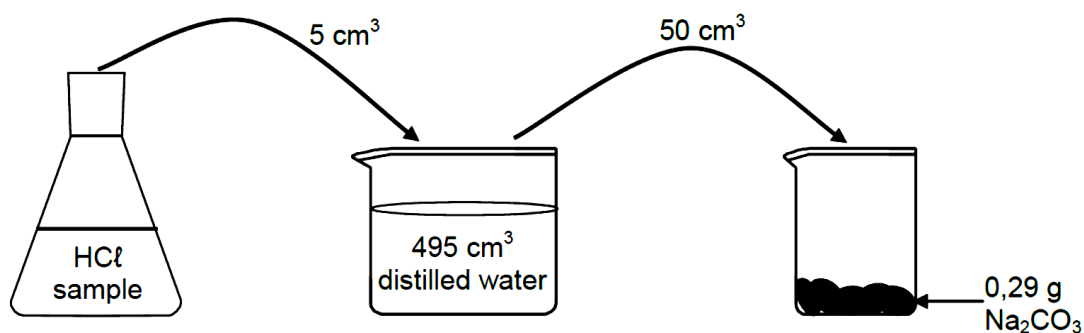

- 10.3 The balanced equation for the reaction is:

$$\text{Na}_2\text{CO}_3(\text{s}) + 2\text{HCl}(\text{aq}) \rightarrow 2\text{NaCl}(\text{aq}) + \text{CO}_2(\text{g}) + \text{H}_2\text{O}(\text{l})$$

 Calculate the concentration of the hydrochloric acid sample. (7)

[17]

QUESTION 11

- 11.1 The balanced equation below represents the first step in the ionisation of sulphuric acid (H_2SO_4) in water: $\text{H}_2\text{SO}_4(\text{l}) + \text{H}_2\text{O}(\text{l}) \rightleftharpoons \text{H}_3\text{O}^+(\text{aq}) + \text{HSO}_4^-(\text{aq})$
- 11.1.1 Write down the FORMULAE of the TWO bases in the equation above. (2)
- 11.1.2 Is sulphuric acid a STRONG or a WEAK acid? Give a reason for the answer. (2)
- 11.2 Learners use the reaction of a $0,15 \text{ mol}\cdot\text{dm}^{-3}$ sulphuric acid solution with a sodium hydroxide solution in two different experiments. The balanced equation for the reaction is: $\text{H}_2\text{SO}_4(\text{aq}) + 2\text{NaOH}(\text{aq}) \rightarrow \text{Na}_2\text{SO}_4(\text{aq}) + \text{H}_2\text{O}(\text{l})$
- 11.2.1 They use 24 cm^3 of $\text{H}_2\text{SO}_4(\text{aq})$ in a titration to neutralise 26 cm^3 of $\text{NaOH}(\text{aq})$. Calculate the concentration of the $\text{NaOH}(\text{aq})$. (5)
- 11.2.2 In another experiment, 30 cm^3 of the $\text{H}_2\text{SO}_4(\text{aq})$ is added to 20 cm^3 of a $0,28 \text{ mol}\cdot\text{dm}^{-3}$ NaOH solution in a beaker. Calculate the pH of the final solution. (8)

[17]

QUESTION 12

The reaction between a sulphuric acid (H_2SO_4) solution and a sodium hydroxide (NaOH) solution is investigated using the apparatus illustrated below.

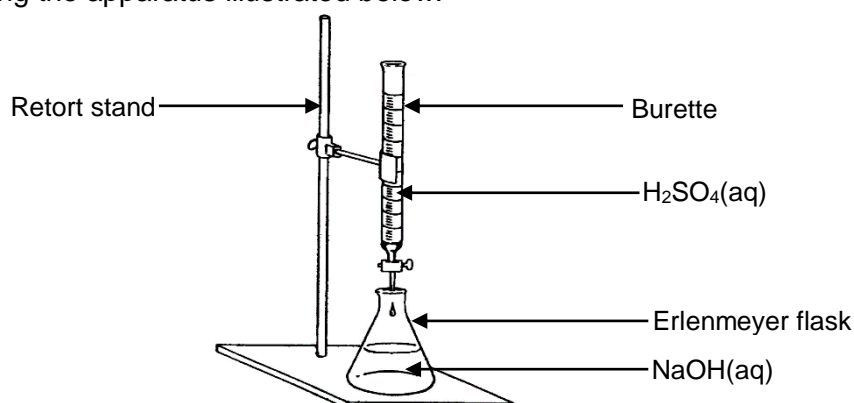

- 12.1 Write down the name of the experimental procedure illustrated above. (1)
- 12.2 What is the function of the burette? (1)
- 12.3 Define an *acid* in terms of the Arrhenius theory. (2)
- 12.4 Give a reason why sulphuric acid is regarded as a strong acid. (1)
- 12.5 Bromothymol blue is used as indicator. Write down the colour change that will take place in the Erlenmeyer flask on reaching the endpoint of the titration. Choose from the following:
 BLUE TO YELLOW YELLOW TO BLUE GREEN TO YELLOW (1)

During the titration a learner adds 25 cm³ of NaOH(aq) of concentration 0,1 mol·dm⁻³ to an Erlenmeyer flask and titrates this solution with H₂SO₄ (aq) of concentration 0,1 mol·dm⁻³. The balanced equation for the reaction that takes place is:

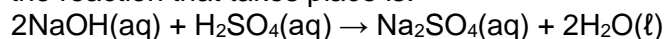

- 12.6 Determine the volume of H₂SO₄(aq) which must be added to neutralise the NaOH(aq) in the Erlenmeyer flask completely. (4)
- 12.7 If the learner passes the endpoint by adding 5 cm³ of the same H₂SO₄(aq) in excess, calculate the pH of the solution in the flask. (7)
- [17]**

QUESTION 13

- 13.1 Sulphuric acid is a strong acid present in acid rain. It ionises in two steps as follows:

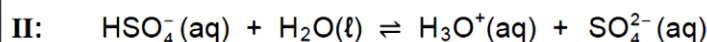
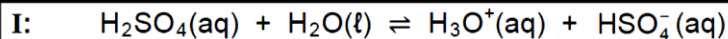

- 13.1.1 Define an *acid* in terms of the Lowry-Brønsted theory. (2)
- 13.1.2 Write down the FORMULA of the conjugate base of H₃O⁺(aq). (1)
- 13.1.3 Write down the FORMULA of the substance that acts as an ampholyte in the ionisation of sulphuric acid. (2)
- 13.2 Acid rain does not cause damage to lakes that have rocks containing limestone (CaCO₃). Hydrolysis of CaCO₃ results in the formation of ions, which neutralise the acid.
- 13.2.1 Define *hydrolysis* of a salt. (2)
- 13.2.2 Explain, with the aid of the relevant HYDROLYSIS reaction, how limestone can neutralise the acid. (3)
- 13.3 The water in a certain lake has a pH of 5.
- 13.1.1 Calculate the concentration of the hydronium ions in the water. (3)
- The volume of water in the lake is 4 x 10⁹ dm³. Lime, CaO, is added to the water to neutralise the acid according to the following reaction:
- $$\text{CaO} + 2\text{H}_3\text{O}^+ \rightleftharpoons \text{Ca}^{2+} + 3\text{H}_2\text{O}$$
- 13.3.2 If the final amount of hydronium ions is 1,26 x 10³ moles, calculate the mass of lime that was added to the lake. (7)
- [20]**

GALVANIC CELLS

QUESTION 1

A standard electrochemical cell is set up using a standard hydrogen half-cell and a standard X|X²⁺ half-cell as shown below. A voltmeter connected across the cell, initially registers 0,31 V.

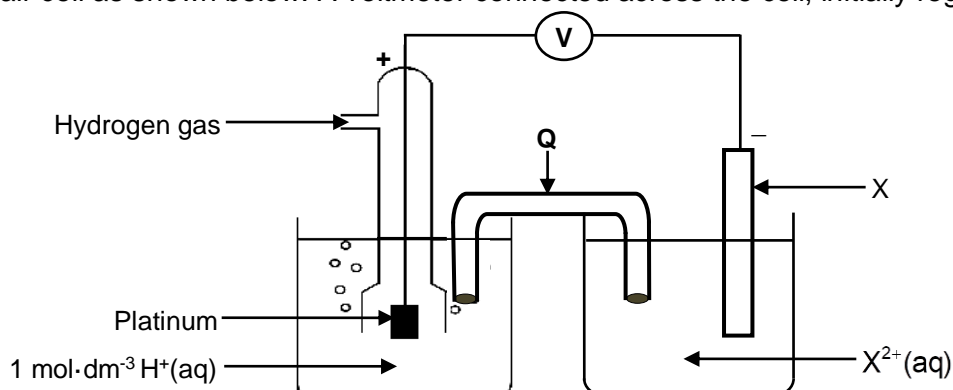

- 1.1 Besides concentration write down TWO conditions needed for the hydrogen half-cell to function under standard conditions. (2)

- 1.2 Give TWO reasons, besides being a solid, why platinum is suitable to be used as electrode in the above cell. (2)
- 1.3 Write down the:
- 1.3.1 NAME of component **Q** (1)
- 1.3.2 Standard reduction potential of the $X|X^{2+}$ half-cell (1)
- 1.3.3 Half-reaction that takes place at the cathode of this cell (2)
- 1.4 The hydrogen half-cell is now replaced by a $M|M^{2+}$ half-cell. The cell notation of this cell is: $M(s) | M^{2+}(aq) || X^{2+}(aq) | X(s)$
The initial reading on the voltmeter is now 2,05 V.
- 1.4.1 Identify metal **M**. Show how you arrived at the answer. (5)
- 1.4.2 Is the cell reaction EXOTHERMIC or ENDOTHERMIC? (1)
- 1.5 The reading on the voltmeter becomes zero after using this cell for several hours. Give a reason for this reading by referring to the cell reaction. (1)

[15]**QUESTION 2**

A learner conducts two experiments to investigate the reaction between copper (Cu) and a silver nitrate solution, $AgNO_3(aq)$.

EXPERIMENT 1

The learner adds a small amount of copper (Cu) powder to a test tube containing silver nitrate solution, $AgNO_3(aq)$. The solution changes from colourless to blue after a while.

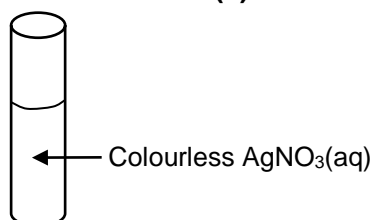
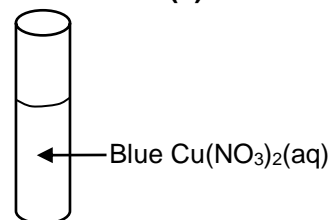
Before addition of Cu(s)**After addition of Cu(s)**

- 2.1 Define the term *oxidising agent*. (2)
- 2.2 Explain why the solution turns blue by referring to the relative strength of oxidising agents. (4)

EXPERIMENT 2

The learner now sets up a galvanic cell as shown below. The cell functions under standard conditions.

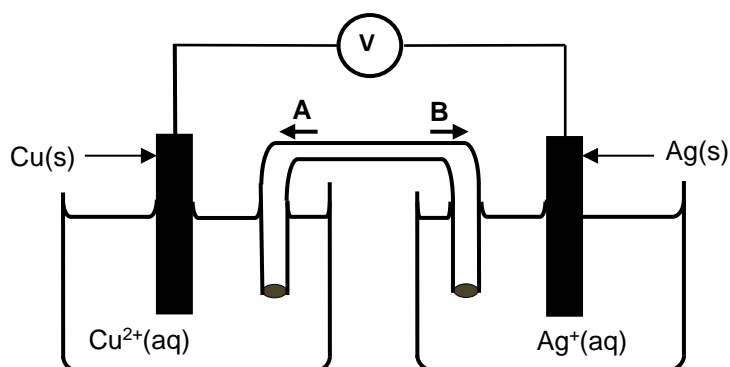

- 2.3 Write down the energy conversion that takes place in this cell. (1)
- 2.4 In which direction (**A** or **B**) will ANIONS move in the salt bridge? (1)
- 2.5 Calculate the emf of this cell under standard conditions. (4)
- 2.6 Write down the balanced equation for the net cell reaction that takes place in this cell. (3)
- 2.7 How will the addition of 100 cm^3 of a $1\text{ mol}\cdot\text{dm}^{-3}$ silver nitrate solution to the silver half-cell influence the initial emf of this cell? Write down only INCREASES, DECREASES or REMAINS THE SAME. (1)

[16]

QUESTION 3

Learners set up an electrochemical cell, shown in the simplified diagram below, using magnesium and lead as electrodes. Nitrate solutions are used as electrolytes in both half-cells.

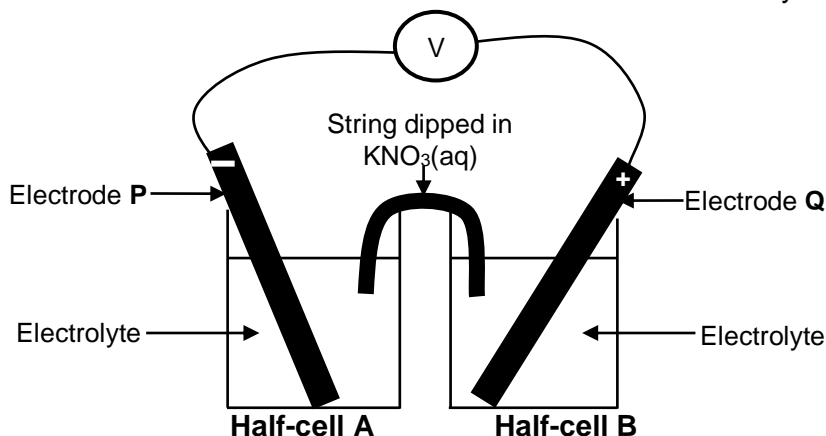

- 3.1 What type of reaction (NEUTRALISATION, REDOX or PRECIPITATION) takes place in this cell? (1)
- 3.2 Which electrode, **P** or **Q**, is magnesium? Give a reason for the answer. (2)
- 3.3 Write down the:
- 3.3.1 Standard conditions under which this cell functions (2)
- 3.3.2 Cell notation for this cell (3)
- 3.3.3 NAME or FORMULA of the oxidising agent in the cell (1)
- 3.4 Calculate the initial emf of the cell above under standard conditions. (4)
- 3.5 How will the voltmeter reading change if the:
(Write down only INCREASES, DECREASES or REMAINS THE SAME.)
- 3.5.1 Size of electrode **P** is increased (1)
- 3.5.2 Initial concentration of the electrolyte in half-cell **B** is increased (1)
- [15]**

QUESTION 4

Learners are given the following two unknown half-cells:



During an investigation to identify the two half-cells, the learners connect each half-cell alternately to a $Cd^{2+}(aq) | Cd(s)$ half-cell under standard conditions. For each combination of two half-cells, they write down the net cell reaction and measure the cell potential. The results obtained for the two half-cell combinations are given in the table below.

COMBINATION	NET CELL REACTION	CELL POTENTIAL
I	$Q^{2+}(aq) + Cd(s) \rightarrow Cd^{2+}(aq) + Q(s)$	0,13 V
II	$R_2(g) + Cd(s) \rightarrow Cd^{2+}(aq) + 2R^-(aq)$	1,76 V

- 4.1 Write down THREE conditions needed for these cells to function as standard cells. (3)
- 4.2 For **Combination I**, identify:
- 4.2.1 The anode of the cell (1)
- 4.2.2 **Q** by using a calculation (5)
- 4.3 For **Combination II**, write down the:
- 4.3.1 Oxidation half-reaction (2)

4.3.2 NAME or FORMULA of the metal used in the cathode compartment (1)

4.4 Arrange the following species in order of INCREASING oxidising ability:
 Q^{2+} ; R_2 ; Cd^{2+} (4)

Explain fully how you arrived at the answer. A calculation is NOT required. [16]

QUESTION 5

An electrochemical cell consisting of half-cells **A** and **B** is assembled under standard conditions as shown below.

Half-cell A	Pt, Cl_2 (101,3 kPa) Cl^- (1 mol·dm ⁻³)
Half-cell B	Mg^{2+} (1 mol·dm ⁻³) Mg(s)

5.1 At which half-cell, **A** or **B**, are electrons released into the external circuit? (1)

5.2 Write down the:

5.2.1 Reduction half-reaction that takes place in this cell (2)

5.2.2 NAME or FORMULA of the substance whose oxidation number DECREASES (1)

5.3 Calculate the initial cell potential of this cell when it is in operation. (4)

5.4 Write down an observation that will be made in half-cell **B** as the cell operates. Give a reason for the answer. (2) [10]

QUESTION 6

Magnesium (Mg) reacts with a dilute hydrochloric acid solution, $HCl(aq)$, according to the following balanced equation: $Mg(s) + 2HCl(aq) \rightarrow MgCl_2(aq) + H_2(g)$

6.1 Give a reason why the reaction above is a redox reaction. (1)

6.2 Write down the FORMULA of the oxidising agent in the reaction above. (1)

It is found that silver does not react with the hydrochloric acid solution.

6.3 Refer to the relative strengths of reducing agents to explain this observation. (3)

The reaction of magnesium with hydrochloric acid is used in an electrochemical cell, as shown in the diagram below. The cell functions under standard conditions.

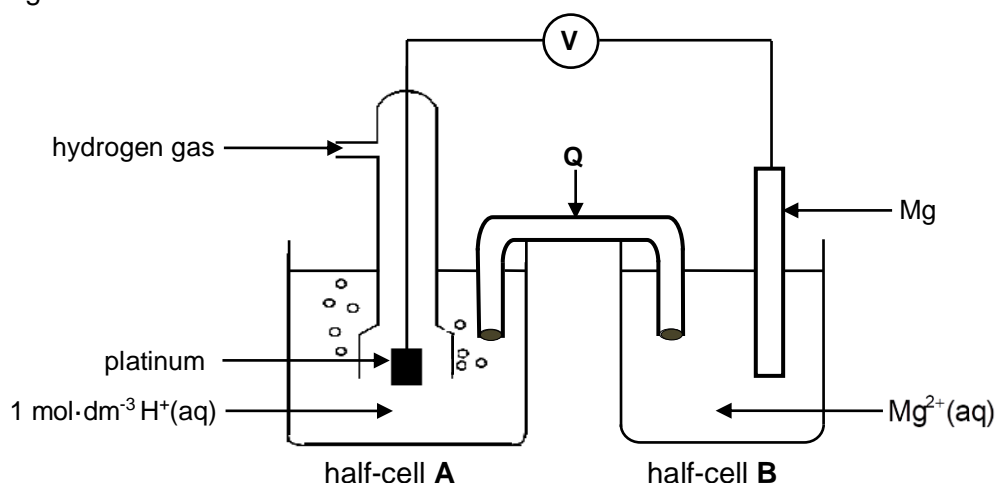

6.4 What is the function of platinum in the cell above? (1)

6.5 Write down the:

6.5.1 Energy conversion that takes place in this cell (1)

6.5.2 Function of **Q** (1)

6.5.3 Half-reaction that takes place at the cathode (2)

6.5.4 Cell notation of this cell (3)

6.6 Calculate the initial emf of this cell. (4)

- 6.7 How will the addition of concentrated acid to half-cell **A** influence the answer to QUESTION 6.6? Choose from INCREASES, DECREASES or REMAINS THE SAME. (1)
[18]

QUESTION 7

- 7.1 A nickel (Ni) rod is placed in a beaker containing a silver nitrate solution, $\text{AgNO}_3(\text{aq})$ and a reaction takes place.

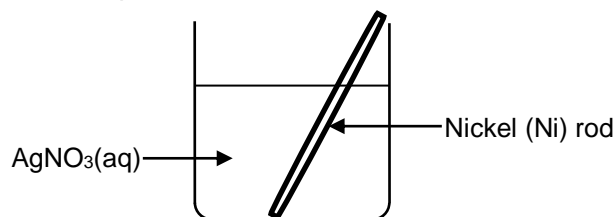

Write down the:

- 7.1.1 NAME or FORMULA of the electrolyte (1)
7.1.2 Oxidation half-reaction that takes place (2)
7.1.3 Balanced equation for the net (overall) redox reaction that takes place (3)
- 7.2 A galvanic cell is now set up using a nickel half-cell and a silver half-cell.

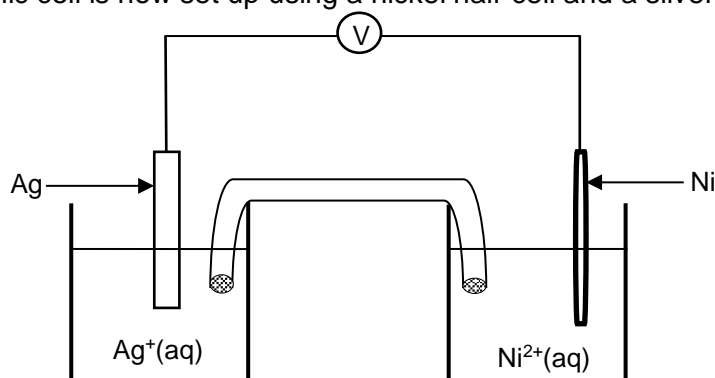

- 7.2.1 Which electrode (**Ni** or **Ag**) must be connected to the negative terminal of the voltmeter? Give a reason for the answer. (2)
7.2.2 Write down the cell notation for the galvanic cell above. (3)
7.2.3 Calculate the initial reading on the voltmeter if the cell functions under standard conditions. (4)
7.2.4 How will the voltmeter reading in QUESTION 7.2.3 be affected if the concentration of the silver ions is increased? Choose from INCREASES, DECREASES or REMAINS THE SAME. (1)
[16]

QUESTION 8

Graph of emf versus $[\text{X}^{2+}]$

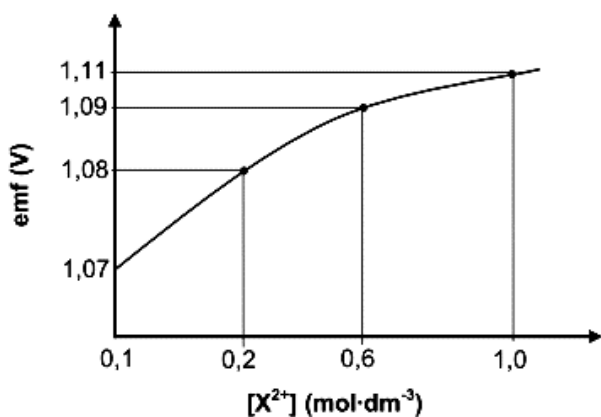

The electrochemical cell represented by the cell notation below is used to investigate the relationship between the concentration of $\text{X}^{2+}(\text{aq})$ and the emf of the cell. The concentration of $\text{Zn}^{2+}(\text{aq})$ and the temperature are kept at standard conditions.

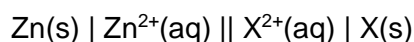

The graph shows the results obtained.

- 8.1 For this investigation, write down the:
- 8.1.1 Dependent variable (1)
8.1.2 Name of an instrument needed to measure the emf of the cell (1)
8.1.3 Name of the component of the cell that ensures electrical neutrality (1)

- 8.1.4 Values of TWO standard conditions needed to ensure that the standard emf is obtained (2)
- 8.2 Write down the conclusion that can be drawn from the results. (2)
- 8.3 Identify electrode **X** with the aid of a calculation. (5)
- 8.4 Write down the overall (net) cell reaction that takes place when this cell is in operation. (3)

[15]**QUESTION 9**

In the electrochemical cell shown below an aluminium electrode and another metal electrode, **Y**, are used.

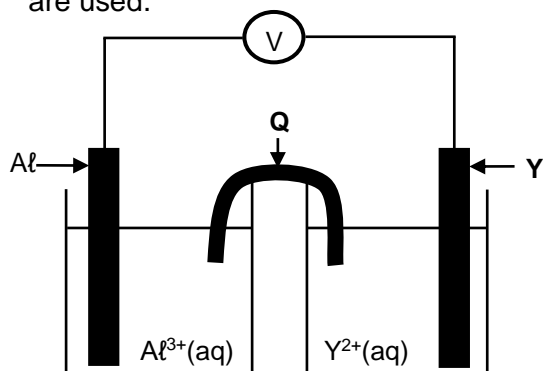

9.1 Write down the:

9.1.1 Name of component **Q** (1)

9.1.2 Type of electrochemical cell represented above (1)

It is found that the mass of the aluminium electrode increases whilst the cell is functioning.

9.2 How will EACH of the following change while the cell is functioning? Choose from INCREASES, DECREASES or REMAINS THE SAME.

9.2.1 The concentration of $\text{Al}^{3+}(\text{aq})$ (1)

9.2.2 The concentration of $\text{Y}^{2+}(\text{aq})$ (1)

9.3 Write down the half-reaction that takes place at electrode **Y**. (2)

9.4 Write down the cell notation of the cell. (3)

9.5 The initial emf of this cell measured under standard conditions is 0,7 V. Identify metal **Y** by means of a calculation. (5)

[14]**QUESTION 10**

10.1 Learners set up a galvanic cell and measure its emf under standard conditions.

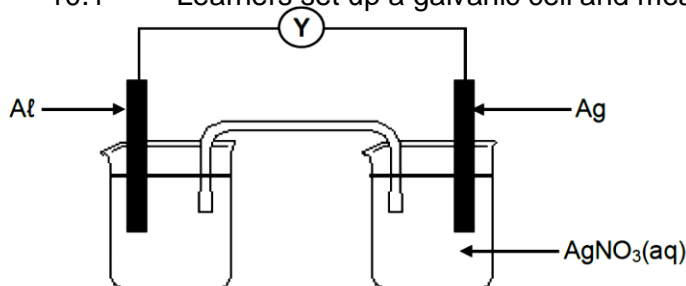

10.1.1 Write down the name of component **Y**. (1)

10.1.2 Is **Al** the ANODE or the CATHODE? (1)

10.1.3 Write down the overall (net) cell reaction that takes place in this cell when it is working. (3)

10.1.4 Calculate the initial emf of this cell. (4)

10.2 Consider the half-cells, **P**, **Q** and **R**, represented in the table below.

HALF-CELL P	HALF-CELL Q	HALF-CELL R
$\text{Zn} \text{Zn}^{2+}(\text{aq})$	$\text{Cl} \text{Cl}^{-}(\text{aq})$	$\text{Cu} \text{Cu}^{2+}(\text{aq})$

Different combinations of the half-cells above are compared to determine the highest emf produced under standard conditions.

10.2.1 Write down the NAME of a suitable electrode for half-cell **Q**. (1)

10.2.2 State the standard conditions under which the half-cells should operate to ensure a fair comparison. (2)

10.2.2 Write down the NAME or FORMULA of the strongest reducing agent in the half-cells above. (1)

10.2.4 Which combination of half-cells will produce the highest emf? Choose from **PR**, **PQ** or **QR**. (NO calculation is required.) (1)

[14]

QUESTION 11

11.1 A group of learners use the redox reaction below to construct an electrochemical cell.

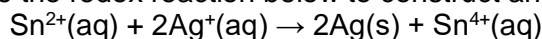

- 11.1.1 Define a *reducing agent* in terms of *electron transfer*. (2)
- 11.1.2 Name a substance that should be used as electrode in the anode half-cell. (1)
- 11.1.3 Write down the NAME or FORMULA of the reducing agent. (1)
- 11.1.4 Write down the cell notation of the cell. (3)
- 11.1.5 Calculate the initial emf of this cell under standard conditions. (4)

11.2 In a separate experiment, the learners place magnesium ribbon in a beaker containing a blue solution of copper(II) sulphate. After a while the solution becomes colourless.

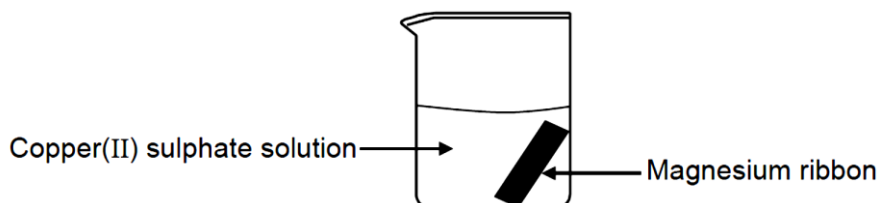

- 11.2.1 State ONE observable change in the beaker, besides a colour change of the solution, that the learners can make. (1)
- 11.2.2 Refer to the relative strengths of oxidising agents or reducing agents to explain why the solution becomes colourless. (3)

[15]**QUESTION 12**

12.1 Consider the electrochemical cell represented by the cell notation below, where **X** is an unknown metal: $\text{Pt}(\text{s}) | \text{Fe}^{2+}(\text{aq}), \text{Fe}^{3+}(\text{aq}) || \text{X}^{+}(\text{aq}) | \text{X}(\text{s})$

The cell potential of this cell was found to be 0,03 V.

- 12.1.1 Write down the type of electrochemical cell illustrated above. (1)
- 12.1.2 What does the single line (|) in the above cell notation represent? (1)
- 12.1.3 Write down the half-reaction that takes place at the anode in the above cell. (2)
- 12.1.4 Identify **X** with the aid of a calculation. (5)

12.2 A $\text{Pt}(\text{s}) | \text{Fe}^{2+}(\text{aq}), \text{Fe}^{3+}(\text{aq})$ half-cell is connected to a $\text{Cu}(\text{s}) | \text{Cu}^{2+}(\text{aq})$ half-cell. Write down the:

- 12.2.1 Chemical symbol for the electrode in the cathode half-cell (1)
- 12.2.2 NAME of the oxidising agent (1)
- 12.2.3 Overall balanced cell reaction that takes place in this cell (3)

[14]**QUESTION 13**

13.1 Corrosion is a redox reaction that takes place in the presence of oxygen and water. Rusting is the corrosion of iron leading to the formation of iron(III) ions.

- 13.1.1 Define *oxidation* in terms of electron transfer. (2)

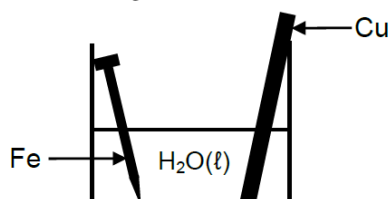

A cleaned copper rod and a cleaned iron nail are placed in a beaker containing water at 25 °C, as shown. After a while it was observed that the iron nail was coated with rust. The copper rod showed no visible signs of corrosion.

- 13.1.2 Write down the half-reaction for the iron nail. (2)
- 13.1.3 Does iron act as REDUCING AGENT or OXIDISING AGENT in the beaker? (1)
- 13.1.4 Explain the above observation by referring to the Table of Standard Reduction Potentials. (3)

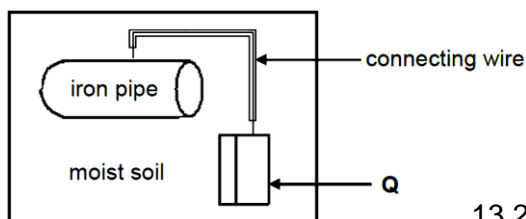

To prevent rusting of an underground iron pipe, the pipe is connected to a metal (**Q**) that corrodes easily.

13.1.5 You are given two metals, Zn and Cu, to use as metal **Q**. Which metal would more suitable? Give a reason. (2)

13.2 A galvanic cell is constructed using a Fe | Fe³⁺ half-cell and a Cu | Cu²⁺ half-cell.

13.2.1 Write down the overall (net) cell reaction that takes place when the cell is functioning. (3)

13.2.2 Calculate the cell potential of this cell under standard conditions. (4)

[17]

ELECTROLYTIC CELLS

QUESTION 1

The simplified diagrams below represent two electrochemical cells, **A** and **B**. A concentrated copper(II) chloride solution is used as electrolyte in both cells.

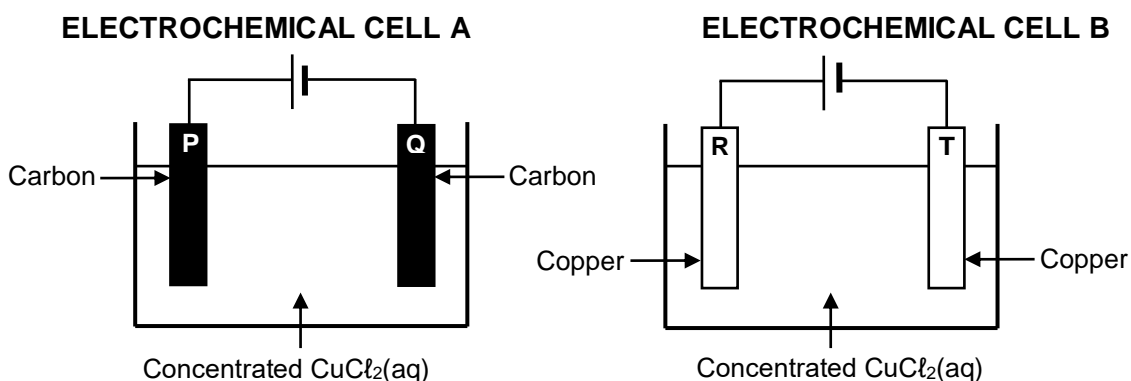

1.1 Are **A** and **B** ELECTROLYTIC or GALVANIC cells? (1)

1.2 Which of the electrodes (**P**, **Q**, **R** or **T**) will show a mass increase? Write down a half-reaction to motivate the answer. (4)

1.3 Write down the NAME or FORMULA of the product formed at:

1.3.1 Electrode **P** (1)

1.3.2 Electrode **R** (1)

1.4 Fully explain the answer to QUESTION 1.3.2 by referring to the relative strengths of the reducing agents involved. (3)

[10]

QUESTION 2

The apparatus below is used to demonstrate the electrolysis of a concentrated sodium chloride solution. Both electrodes are made of carbon. A few drops of universal indicator are added to the electrolyte. The equation for the net cell reaction is:

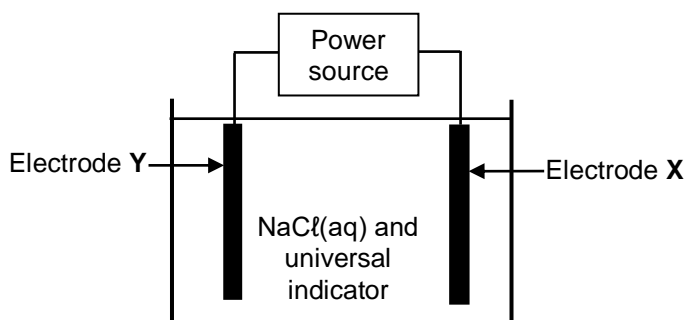
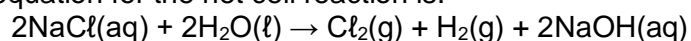

Initially the solution has a green colour. Universal indicator becomes red in acidic solutions and purple in alkaline solutions.

2.1 Define the term *electrolyte*. (2)

When the power source is switched on, the colour of the electrolyte around electrode **Y** changes from green to purple.

2.2 Write down the half-reaction that takes place at electrode **Y**. (2)

- 2.3 Write down the NAME or FORMULA of the gas released at electrode X. (1)
- 2.4 Refer to the Table of Standard Reduction Potentials to explain why hydrogen gas, and not sodium, is formed at the cathode of this cell. (2)
- [7]

QUESTION 3

The diagram shows a simplified electrolytic cell that can be used to electroplate a plastic ring with nickel. Prior to electroplating the ring is covered with a graphite layer.

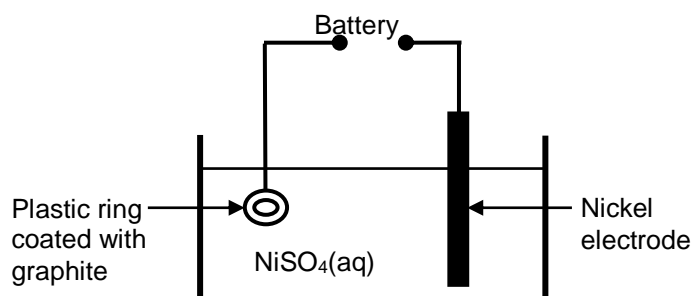

- 3.1 Define the term *electrolyte*. (2)
- 3.2 Give ONE reason why the plastic ring must be coated with graphite prior to electroplating. (1)
- 3.3 Write down the half-reaction that occurs at the plastic ring. (2)
- 3.4 Write down the NAME or FORMULA of the reducing agent in the cell. Give a reason for the answer. (2)
- 3.5 Which electrode, the **RING** or **NICKEL**, is the cathode? Give a reason for the answer. (2)
- The nickel electrode is now replaced with a carbon rod.
- 3.6 How will the concentration of the electrolyte change during electroplating? Write down only INCREASES, DECREASES or NO CHANGE. Give a reason for the answer. (2)
- [11]

QUESTION 4

The simplified diagram represents an electrochemical cell used for the purification of copper.

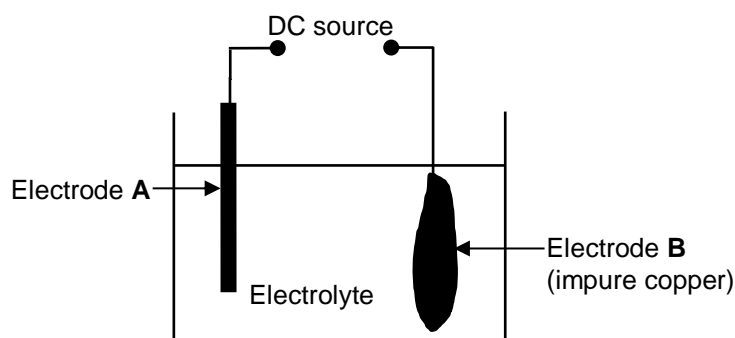

- 4.1 Define the term *electrolysis*. (2)
- 4.2 Give a reason why a direct-current (DC) source is used in this experiment. (1)
- 4.3 Write down the half-reaction which takes place at electrode A. (2)
- 4.4 Due to small amounts of zinc impurities in the impure copper, the electrolyte becomes contaminated with Zn^{2+} ions. Refer to the attached Table of Standard Reduction Potentials to explain why the Zn^{2+} ions will not influence the purity of the copper obtained during this process. (3)
- 4.5 After the purification of the impure copper was completed, it was found that $2,85 \times 10^{-2}$ moles of copper were formed. The initial mass of electrode B was 2,0 g. Calculate the percentage of copper that was initially present in electrode B. (4)
- [12]

QUESTION 5

The electrochemical cell below is set up to demonstrate the purification of copper.

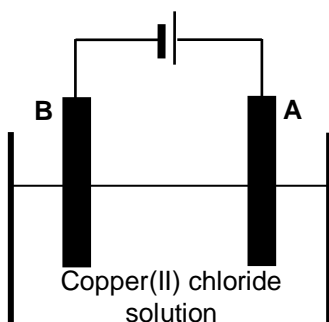

- 5.1 Write down the type of electrochemical cell illustrated above. (1)

The graphs below show the change in mass of the electrodes whilst the cell is in operation.

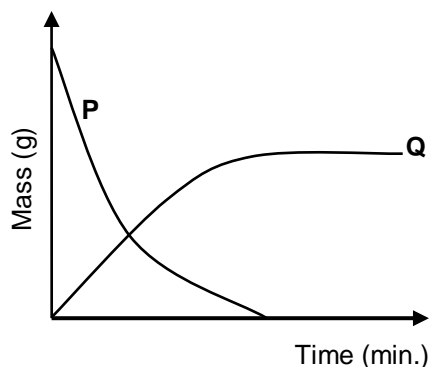

- 5.2 Define a *reducing agent* in terms of electron transfer. (2)
- 5.3 Which graph represents the change in mass of electrode **A**? (1)
- 5.4 Write down the half-reaction that takes place at electrode **A**. (2)
- 5.5 Electrodes **A** and **B** are now replaced by graphite electrodes. It is observed that chlorine gas (Cl_2) is released at one of the electrodes. At which electrode (**A** or **B**) is chlorine gas formed? Fully explain how it is formed. (3)
- [9]**

QUESTION 6

The diagram below shows an electrochemical cell used to purify copper. A solution that conducts electricity is used in the cell.

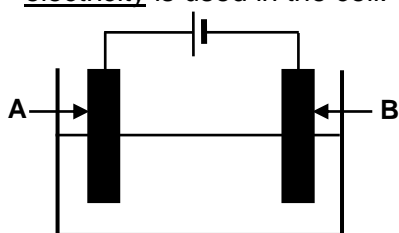

- 6.1 Write down:
- 6.1.1 ONE word for the underlined phrase above the diagram (1)
- 6.1.2 The type of electrochemical cell illustrated above (1)
- 6.2 In which direction (**from A to B** or **from B to A**) will electrons flow in the external circuit? (1)
- 6.3 Which electrode (**A** or **B**) is the:
- 6.3.1 Cathode (1)
- 6.3.2 Impure copper (1)
- 6.4 How will the mass of electrode **A** change as the reaction proceeds? Choose from INCREASES, DECREASES or REMAINS THE SAME. Give a reason for the answer. **[7]**

QUESTION 7

In the electrochemical cell below, carbon electrodes are used during the electrolysis of a concentrated sodium chloride solution. The balanced equation for the net (overall) cell reaction is: $2\text{H}_2\text{O}(\ell) + 2\text{Cl}^-(\text{aq}) \rightarrow \text{Cl}_2(\text{g}) + \text{H}_2(\text{g}) + 2\text{OH}^-(\text{aq})$

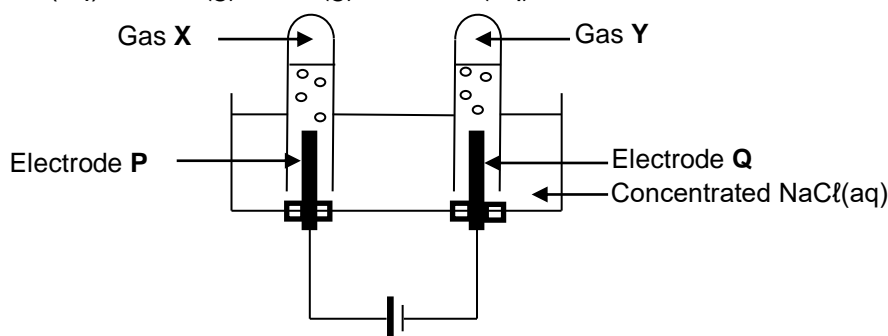

- 7.1 Is the reaction EXOTHERMIC or ENDOTHERMIC? (1)
- 7.2 Is electrode **P** the ANODE or the CATHODE? Give a reason for the answer. (2)
- 7.3 Write down the NAME or FORMULA of:
- 7.3.1 Gas **X** (1)
- 7.3.2 Gas **Y** (1)
- 7.4 Write down the reduction half-reaction. (2)
- 7.5 Is the solution in the cell ACIDIC or ALKALINE (BASIC) after completion of the reaction? Give a reason for the answer. (2)
- [9]**

QUESTION 8

The simplified diagram below represents a cell used to electroplate an iron medal with a thin layer of gold.

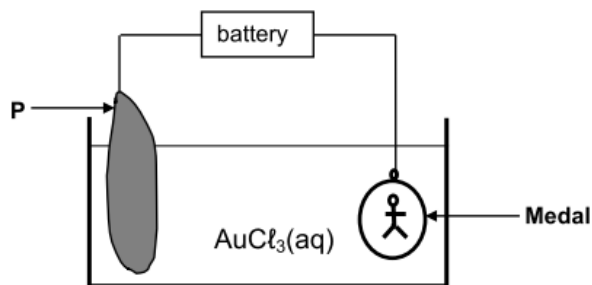

- 8.1 Is this an ELECTROLYTIC or a GALVANIC cell? (1)
- 8.2 Which electrode, **P** or the **Medal**, is the anode? (1)
- 8.3 Write down the:
- 8.3.1 Half-reaction that takes place at electrode **P** (2)
- 8.3.2 Oxidation number of gold (Au) in the electrolyte (1)
- 8.3.3 Energy change that takes place in this cell (1)
- 8.3.4 Visible change that occurs on electrode **P** after the cell functions for a while (1)
- 8.4 Besides improving appearance, state ONE other reason why the medal is electroplated. (1)
- 8.5 State ONE of the two possible changes that should be made to the cell above to electroplate the medal with silver instead of gold. (1)
- [9]**

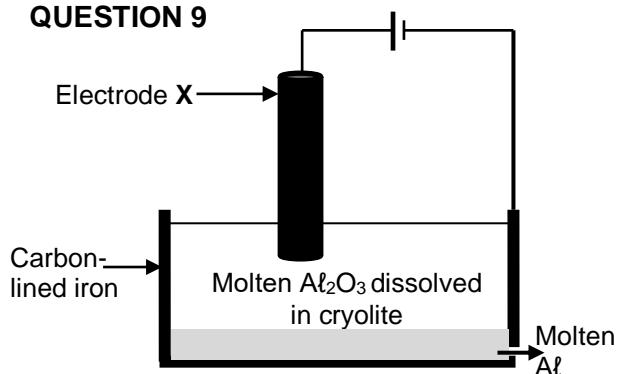
QUESTION 9

The simplified diagram alongside shows an electrolytic cell used in the industrial extraction of aluminium (Al) from aluminium oxide at temperatures as high as 1 000 °C. Electrode **X** is a carbon rod.

The cell reaction that takes place is as follows:
 $2\text{Al}_2\text{O}_3(\ell) \rightarrow 4\text{Al}(\ell) + 3\text{O}_2(\text{g})$

- 9.1 Write down the name of the ore used as source of aluminium oxide. (1)
- 9.2 Which half-reaction (OXIDATION or REDUCTION) takes place at electrode **X**? (1)
- 9.3 What is the function of the cryolite? (1)
- 9.4 Write down the reduction half-reaction. (2)
- 9.5 Write down a balanced equation that shows why the carbon rod, **X**, must be replaced regularly. (3)
- [8]**

QUESTION 10

The simplified diagram below represents an electrochemical cell used in the refining of copper. One of the electrodes consists of impure copper.

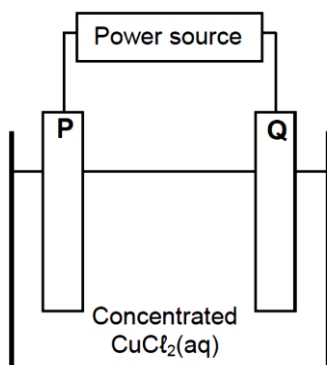

- 10.1 What type of power source, AC or DC, is used to drive the reaction in this cell? (1)
- 10.2 When an electric current passes through the $\text{CuCl}_2(\text{aq})$, the mass of electrode **P** increases. Is electrode **P** the CATHODE or the ANODE? Write down the relevant half-reaction to support the answer. (3)
- 10.3 The impure copper contains zinc impurities which are oxidised to zinc ions. Refer to the relative strengths of oxidising agents to explain why zinc ions will not influence the quality of the pure copper produced in this cell. (3)
- 10.4 Electrodes **P** and **Q** are now replaced by carbon electrodes.
- 10.4.1 What will be observed at electrode **Q**? (1)

- 10.4.2 How will the concentration of the electrolyte change as the reaction proceeds? Choose from INCREASES, DECREASES or REMAINS THE SAME. (1)

[9]

QUESTION 11

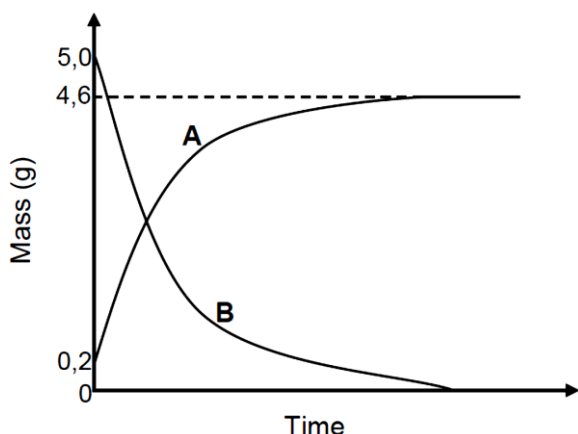

The graph represents the changes in mass that occur at electrode **A** and electrode **B** in an electrolytic cell during the purification of copper.

- 11.1 Define *electrolysis*. (2)
- 11.2 Which graph, **A** or **B**, represents the change in mass of the anode during electrolysis? (1)
- 11.3 Write down the equation of the half-reaction which takes place at the cathode of this cell. (2)
- 11.4 Use the information in the graph and calculate the percentage purity of the impure copper. (4)

[9]

QUESTION 12

The diagram below shows an electrolytic cell used to electroplate an iron rod with COPPER. Solution **X** is made up of an unknown NITRATE.

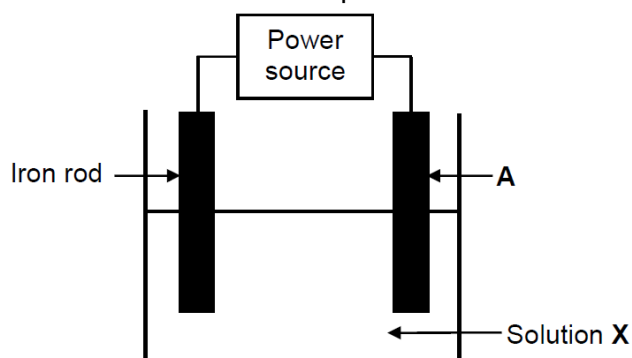

- 12.1 Solutions, such as solution **X**, are always used in electrochemical cells. (2)
- 12.1.1 Write down the general term used to describe these solutions. (1)
- 12.1.2 What is the function of these solutions in electrochemical cells? (1)
- 12.2 Write down the FORMULA of solution **X**. (1)
- 12.3 Which electrode (**A** or **IRON ROD**) is the negative electrode? Give a reason for the answer. (2)
- 12.4 Write down the half-reaction that takes place at electrode **A**. (2)
- 12.5 Electrode **A** is now replaced by a silver rod without making any other changes to the cell. After a while, TWO metallic ions are found to be present in the solution. (2)
- 12.5.1 Name the TWO metallic ions present in the solution. (2)
- 12.5.2 Refer to the relative strengths of oxidising agents to explain which ONE of the two ions will preferably be involved in the plating process. (2)

[11]

QUESTION 13

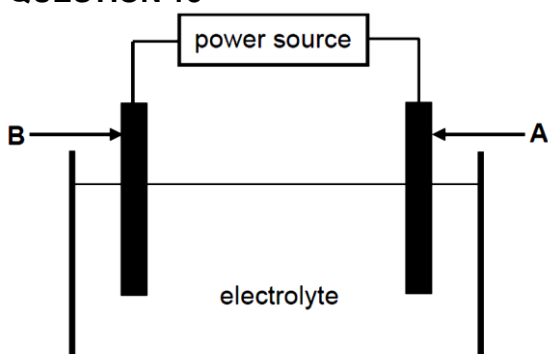

The electrolytic cell below is set up to obtain pure copper from a piece of impure copper. The impure copper contains other metals, such as platinum, iron, cobalt, silver and nickel. The cell potential of the power source is adjusted so that only copper is deposited on electrode **B**.

- 13.1 Define an *electrolytic cell*. (2)
- 13.2 Write down the FORMULA of a suitable electrolyte for this cell. (1)
- 13.3 Which electrode (**A** or **B**) is the cathode? Write down the relevant half-reaction taking place at this electrode. (3)
- 13.4 Sludge forms below one of the electrodes while the cell above is in operation. Which of the metals, PLATINUM, IRON, COBALT, SILVER or NICKEL, will be present in the sludge? (2)

[8]

FERTILISERS

QUESTION 1

- 1.1 The flow diagram below shows the processes involved in the industrial preparation of fertiliser **Q**.

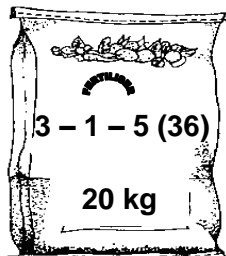
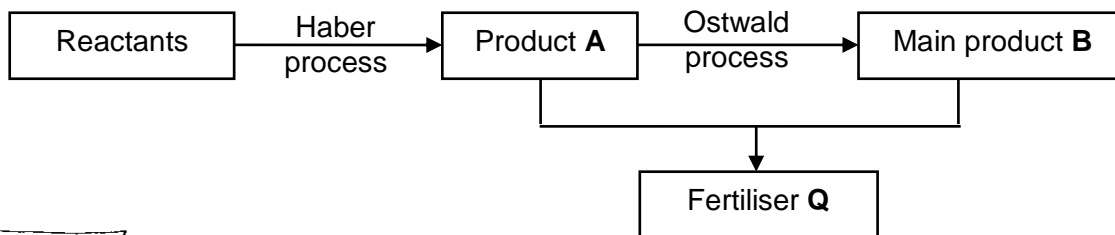

Write down the:

- 1.1.1 NAMES or FORMULAE of the reactants used in the Haber process (2)
- 1.1.2 Balanced equation for the formation of fertiliser **Q** (3)
- 1.2 The diagram alongside shows a bag of NPK fertiliser. Calculate the mass of nitrogen in the bag. (4)
- [9]**

QUESTION 2

Reactions **A**, **B**, **C** and **D** in the flow diagram below represent the manufacturing of Fertiliser **X**.

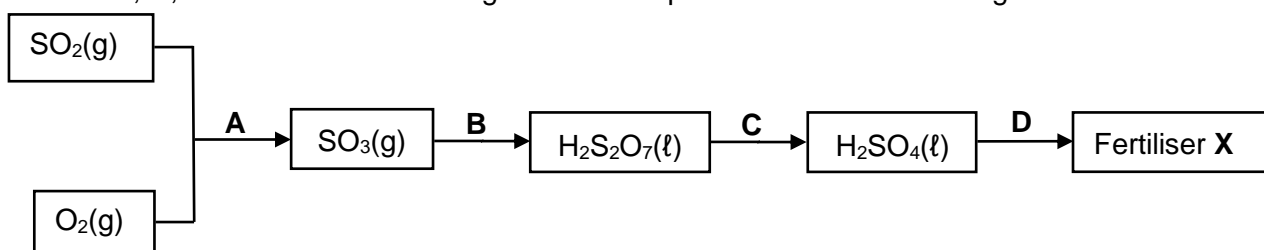

- 2.1 Write down the name of the industrial preparation of sulphuric acid. (1)
- 2.2 Write down the:
- 2.2.1 NAME or FORMULA of the catalyst used in reaction **A** (1)
- 2.2.2 Balanced equation for reaction **C** (3)
- 2.3 Ammonia is one of the reactants used in reaction **D** to make Fertiliser **X**. Write down:
- 2.3.1 A balanced equation for reaction **D** (3)
- 2.3.2 The NAME of Fertiliser **X** (1)
- 2.4 Two 50 kg bags, containing fertilisers **P** and **Q** respectively, are labelled as follows:
- Fertiliser **P**: 5 : 2 : 3 (25)
- Fertiliser **Q**: 1 : 3 : 4 (20)
- 2.4.1 What do the numbers (25) and (20) on the labels represent? (1)
- 2.4.2 Using calculations, determine which fertiliser (**P** or **Q**) contains the greater mass of potassium. (4)
- [14]**

QUESTION 3

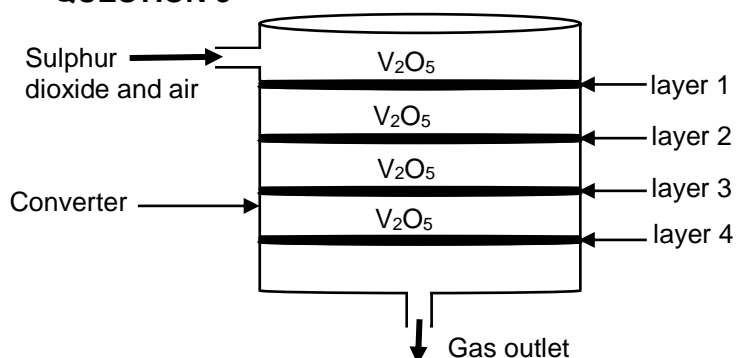

The industrial process for the preparation of sulphuric acid involves a series of stages. The second stage in this process involves the conversion of sulphur dioxide into sulphur trioxide in a converter as illustrated below. In the converter the gases are passed over vanadium pentoxide (V_2O_5) placed in layers as shown.

3.1 Write down the:

3.1.1 Balanced equation for the reaction taking place in the converter (3)

3.1.2 Function of the vanadium pentoxide (1)

The table below shows data obtained during the second stage.

VANADIUM PENTOXIDE LAYER	TEMPERATURE OF GAS BEFORE THE REACTION (°C)	TEMPERATURE OF GAS AFTER THE REACTION (°C)	PERCENTAGE OF REACTANT CONVERTED TO PRODUCT
1	450	600	66
2	450	518	85
3	450	475	93
4	450	460	99,5

3.2 Is the reaction in the second stage EXOTHERMIC or ENDOTHERMIC? Refer to the data in the table to give a reason for the answer. (2)

3.3 After the conversion at each layer the gases are cooled down to 450 °C. Fully explain why the gases must be cooled to this temperature. (3)

3.4 During the third stage sulphur trioxide is dissolved in sulphuric acid rather than in water to produce oleum.

3.4.1 Write down the FORMULA of oleum. (1)

3.4.2 Give a reason why sulphur trioxide is not dissolved in water. (1)

3.5 Sulphuric acid reacts with ammonia to form a fertiliser. Write down a balanced equation for this reaction. (3) [14]

QUESTION 4

Ammonia is an important fertiliser. Large amounts are prepared from hydrogen and nitrogen in industry.

4.1 For the industrial preparation of ammonia, write down:

4.1.1 The name of the process used (1)

4.1.2 A balanced equation for the reaction that occurs (3)

4.1.3 The source of nitrogen (1)

4.2 The yield of ammonia changes with temperature and pressure during its industrial preparation. The graphs below show how the percentage of ammonia in the reaction mixture that leaves the reaction vessel varies under different conditions.

GRAPHS OF THE PERCENTAGE OF AMMONIA IN THE REACTION MIXTURE VERSUS PRESSURE

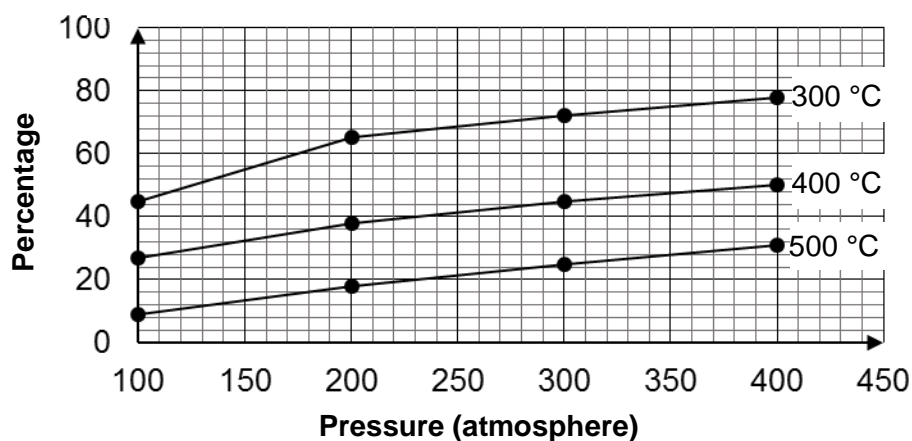

4.2.1 Use the appropriate graph to estimate the percentage of ammonia present in the reaction mixture at 240 atmosphere and 400 °C. (1)

- 4.2.2 State TWO advantages of using high pressure in the preparation of ammonia. (2)
- 4.2.3 The advantage of using a low temperature is the large percentage of ammonia formed. What is the disadvantage of using a low temperature? (1)
- 4.3 Ammonia is also used in the preparation of other fertilisers such as ammonium nitrate. Calculate the mass of nitrogen in a 50 kg bag of pure ammonium nitrate fertiliser. (3)

[12]**QUESTION 5**

Ammonium nitrate is an important fertiliser. It is produced by reacting nitric acid with ammonia. Both nitric acid and ammonia are prepared on a large scale in industry.

- 5.1 Write down the name of the industrial preparation of nitric acid. (1)
- 5.2 The catalytic oxidation of ammonia is one of the steps in the process named in QUESTION 5.1. Write down the NAMES or FORMULAE of the TWO products formed in this step. (2)
- 5.3 Write down a balanced equation for the preparation of ammonium nitrate. (3)
- 5.4 Calculate the mass, in kilogram, of ammonium nitrate that can be made from $6,8 \times 10^4$ kg of ammonia and excess nitric acid. (One mole of ammonia produces one mole of ammonium nitrate.) (3)
- 5.5 Ammonium nitrate is often mixed with potassium chloride and ammonium phosphate. Give a reason why it is mixed with these compounds. (1)

[10]**QUESTION 6**

A chemical company produces ammonium sulphate, $(\text{NH}_4)_2\text{SO}_4$, starting from the raw materials P, Q and R, as shown in the flow diagram below.

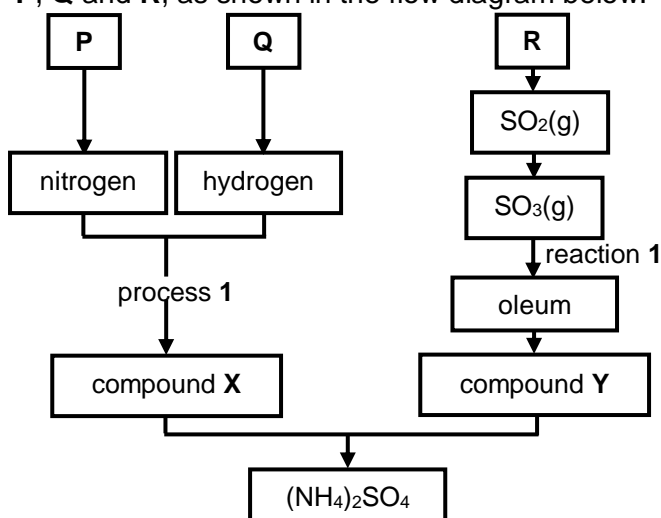

- 6.1 Write down the NAME of raw material: (1)
- 6.1.1 P (1)
- 6.1.2 Q (1)
- 6.1.3 R (1)
- 6.2 Write down the: (1)
- 6.2.1 NAME of process 1 (1)
- 6.2.2 NAME of compound X (1)
- 6.2.3 FORMULA of compound Y (1)
- 6.2.4 Balanced equation for reaction 1 (3)
- 6.3 The company compares the nitrogen content of ammonium sulphate with that of ammonium nitrate, NH_4NO_3 . (4)
- 6.3.1 Determine, by performing the necessary calculations, which ONE of the two fertilisers has the higher percentage of nitrogen per mass. (4)
- 6.3.2 Write down the name of the process that should be included in the flow diagram above if the company wants to prepare ammonium nitrate instead of ammonium sulphate. (1)

[14]

QUESTION 7

- 7.1 The flow diagram below shows the processes involved in the industrial preparation of fertiliser **Q**.

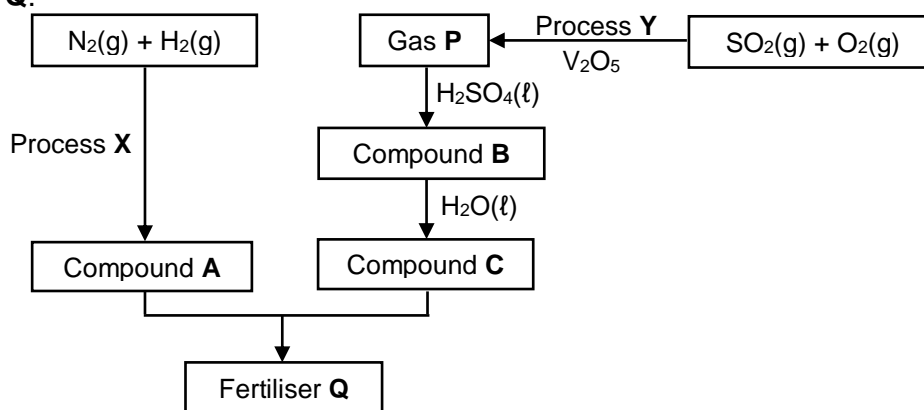

Write down the:

- 7.1.1 Name of process **X** (1)
 7.1.2 Name of process **Y** (1)
 7.1.3 NAME or FORMULA of gas **P** (1)
 7.1.4 Balanced equation for the formation of compound **B** (3)
 7.1.5 Balanced equation for the formation of fertiliser **Q** (4)

- 7.2

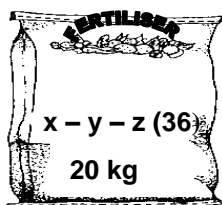

The diagram alongside shows a bag of NPK fertiliser of which the NPK ratio is unknown. It is found that the mass of nitrogen in the bag is 4,11 kg and the mass of phosphorus is 0,51 kg.

Calculate the NPK ratio of the fertiliser.

(4)
[14]

QUESTION 8

- 8.1 The letters **A** to **F** in the table below represent some fertilisers and raw materials used in the preparation of fertilisers.

A	Sulphur	B	Air
B	Methane	E	Potassium chloride
C	Ammonium sulphate	F	Ammonium nitrate

Write down the:

- 8.1.1 LETTERS representing TWO raw materials used in the preparation of compound **F** (2)
 8.1.2 NAME or FORMULA of the acid needed to prepare compound **F** (1)
 8.1.3 LETTER representing the solid raw material used in the contact process (1)
 8.1.4 Balanced equation for the preparation of compound **E** (3)
 8.1.5 LETTER representing the raw material that supplies the primary nutrient needed for development of flowers (1)
- 8.2 A 2 kg bag of fertiliser is labelled as follows: **2 : 3 : 2 (22)**
 Calculate the mass of the:
- 8.2.1 Phosphorous in the bag (3)
 8.2.2 Filler in the bag (3)

[14]

QUESTION 9

9.1 The reactions represented below take place during one of the industrial processes used in the fertiliser industry.

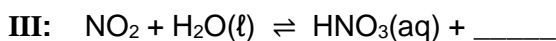
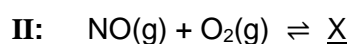
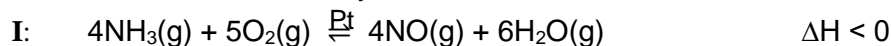

Write down:

9.1.1 The name of this industrial process (1)

9.1.2 The function of Pt in reaction I (1)

9.1.3 The NAME of product X (1)

9.1.4 A balanced equation for reaction III (2)

9.1.5 TWO ways in which the yield of the NO(g) obtained in reaction I can be increased without changing the amount of reactants and products (2)

9.2 NPK fertilisers contain NH_4NO_3 , $(\text{NH}_4)_3\text{PO}_4$ and KCl in varying proportions.

9.2.1 What does *NPK* mean? (1)

9.2.2  Consider the fertiliser illustrated alongside.

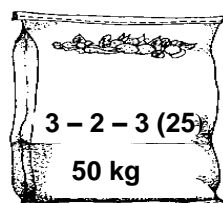

Calculate the mass, in kg, of KCl needed to produce this fertiliser.

(6)
[14]

QUESTION 10

10.1 The equations below represent two industrial processes involved in the preparation of ammonium nitrate.

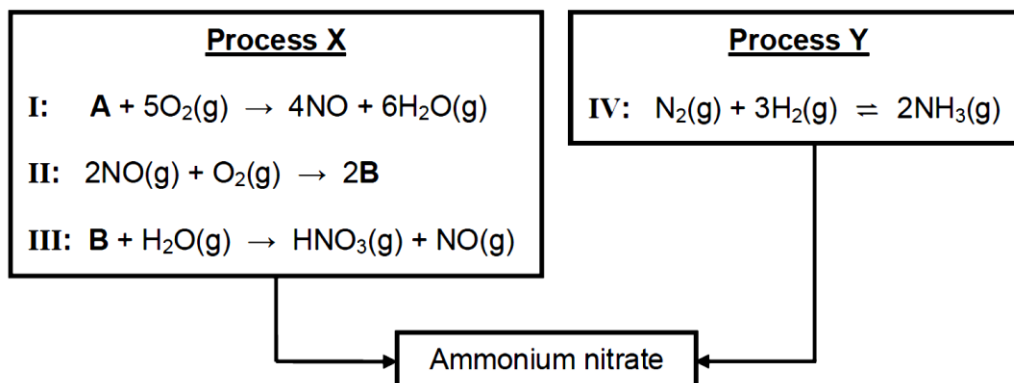

Write down the:

10.1.1 NAME of substance A (1)

10.1.2 FORMULA of substance B (1)

10.1.3 NAME given for reaction I (1)

10.1.4 NAME or FORMULA of the catalyst used in reaction I (1)

10.1.5 Name of process X (1)

10.1.6 Name of process Y (1)

10.1.7 Balanced equation for the preparation of ammonium nitrate from the products obtained in process X and process Y (3)

10.2 A 15 kg bag of fertiliser contains 5% phosphorus, 10% nitrogen and 15% potassium. Calculate the:

10.2.1 Mass of phosphorus in the bag (2)

10.2.2 Mass of filler in the bag

(3)
[14]**QUESTION 11**

11.1 The diagram below shows processes involved in the production of fertiliser **X** and fertiliser **Z**.

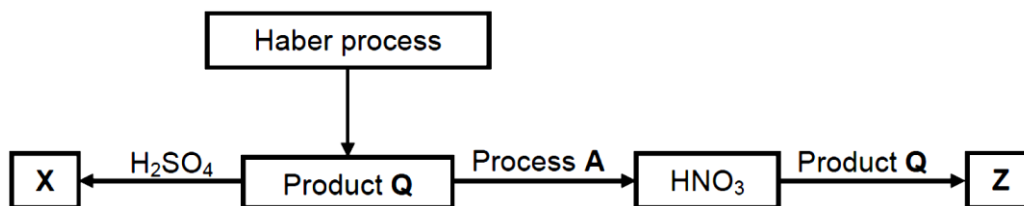

Write down the:

- 11.1.1 Balanced equation for the formation of product **Q** (3)
- 11.1.2 FORMULA of fertiliser **X** (1)
- 11.1.3 NAME of process **A** (1)
- 11.1.4 NAME of fertiliser **Z** (1)
- 11.2 A 10 kg bag of NPK fertiliser is labelled 6 : 1 : 5 (22). (22)
- 11.2.1 What is the meaning of NPK? (1)
- 11.2.2 What is the meaning of (22) on the label? (1)
- 11.2.3 Calculate the mass of potassium in the bag. (4)

[12]

QUESTION 12

The flow diagram below shows the steps used to prepare fertilisers **X** and **Y**. Labels **I** and **II** represent types of chemical reactions and **P** is a compound.

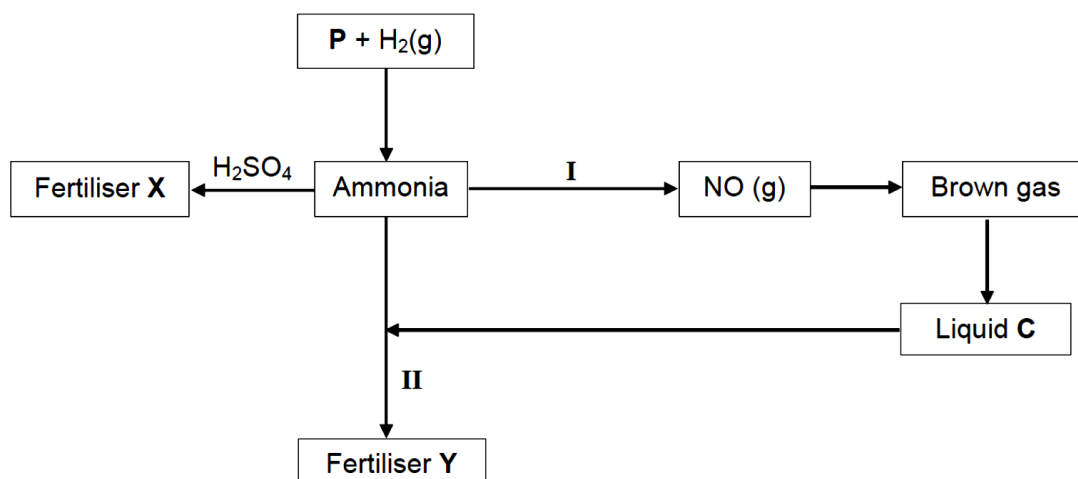

- 12.1 Write down the NAME of the reaction labelled:
- 12.1.1 **I** (1)
- 12.1.2 **II** (1)
- 12.2 Write down the NAME or FORMULA of:
- 12.2.1 Compound **P** (1)
- 12.2.2 The brown gas (1)
- 12.2.3 Liquid **C** (1)
- 12.3 Write down a balanced equation for:
- 12.3.1 The preparation of fertiliser **X** (3)

10.3.2 Reaction I

(3)

12.4 Fertiliser Y is ammonium nitrate. Calculate the mass percentage of nitrogen in fertiliser Y.

(3)

[14]**QUESTION 13**

In the flow diagram below, **I** and **II** represent industrial processes used in the fertiliser industry. **P** and **Q** are chemical reactions that take place to produce ammonium sulphate and fertiliser Y respectively.

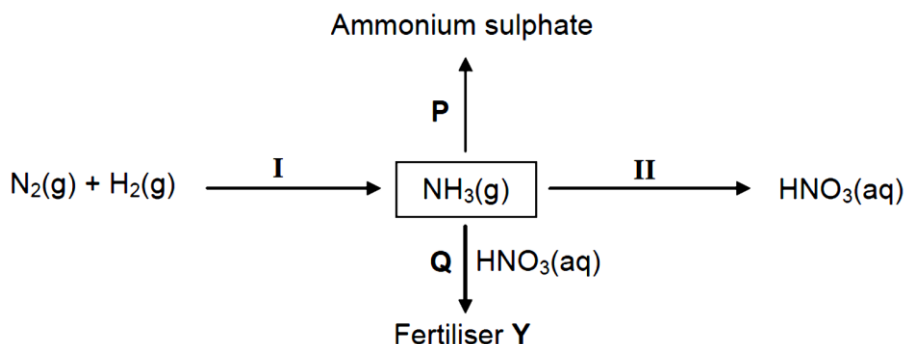

13.1 Write down the name of the industrial process:

13.1.1 **I**

(1)

13.1.2 **II**

(1)

13.2 Write down the formula of:

13.2.1 Fertiliser Y

(1)

13.2.2 The catalyst used in process I

(1)

13.3 In reaction **P**, $\text{NH}_3(\text{g})$ reacts with another substance. Write down a balanced equation for this reaction.

(3)

13.4 The following substances are present in a bag of fertiliser:

- 20 kg ammonium nitrate (NH_4NO_3)
- 12 kg sodium phosphate (Na_3PO_4)
- 18 kg potassium chloride (KCl)

(5)

Calculate the NPK ratio of the fertiliser.

[12]

ANSWERS TO QUESTIONS

ORGANIC MOLECULES: NOMENCLATURE

QUESTION 1

1.1.1 B ✓ (1)

1.1.2 E ✓ (1)

1.1.3 F ✓ (1)

1.2.1 2-bromo-3-chloro-4-methylpentane

Marking criteria

- Correct stem i.e. pentane. ✓
- All substituents correctly identified. ✓
- Substituents correctly numbered, in alphabetical order, hyphens & commas correct. ✓

(3)

1.2.2 Ethene ✓ (1)

1.3.1

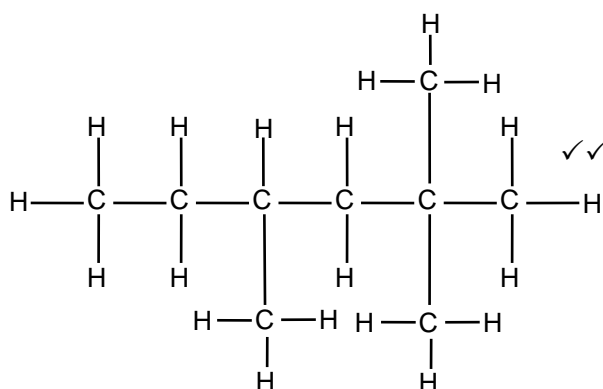

Marking criteria

- Six saturated C atoms in longest chain i.e. hexane. ✓.
- Three methyl substituents on 2nd C and 4th C atom. ✓

(1)

(2)

1.3.2

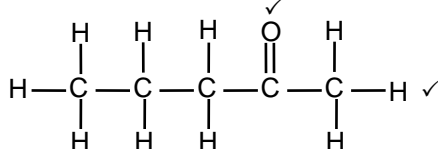

Marking criteria

- Whole structure correct: ✓✓
- Only functional group correct: ✓

(2)

1.4.1 Compounds with the same molecular formula ✓ but DIFFERENT functional groups. ✓ (2)

1.4.2 B & F ✓ (1)

[14]

QUESTION 2

2.1.1 Carboxyl group ✓ (1)

2.1.2 Ketones ✓ (1)

2.1.3 Addition ✓ (1)

2.2.1 Ethene ✓ (1)

2.2.2 4-methylhexan-3-one ✓ (2)

2.2.3 4-ethyl-2,2-dimethylhexane ✓ (2)

2.3 Carbon dioxide/CO₂ ✓ and water/H₂O ✓ (2)

2.4.1

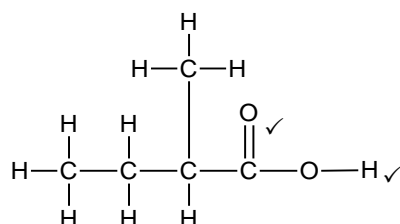

Marking criteria

- Whole structure correct: ✓✓
- Only functional group correct: ✓

(2)

2.4.2

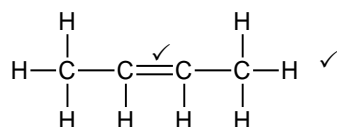

OR

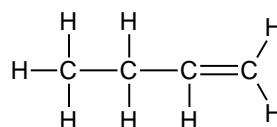

(2)

2.5.1 E ✓ (1)

2.5.2 Substitution / halogenation / bromination ✓ (1)

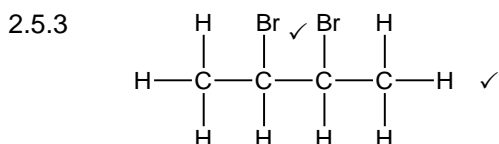
**Marking criteria**

- Whole structure correct: ✓✓
- Only functional group correct: ✓

(2)
[18]**QUESTION 3**

3.1.1 B ✓ (1)

3.1.2 E ✓ (1)

3.1.3 A ✓ (1)

3.2.1 4-chloro-2,5-dimethylheptane

Marking criteria

- Correct stem i.e. heptane. ✓
- All substituents (chloro and dimethyl) correctly identified. ✓
- Substituents correctly numbered, in alphabetical order, hyphens and commas correctly used. ✓

(3)

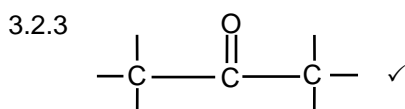
3.2.2 2-methyl✓ propan-1-ol ✓ (2)

(1)

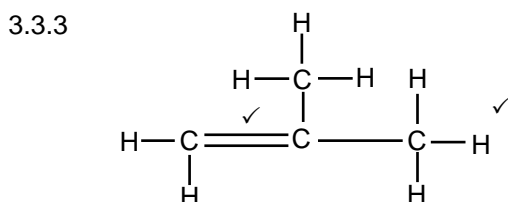
3.3.1 Compounds with the same molecular formula✓ but different POSITIONS of the functional group / side chain / substituents on parent chain. ✓ (2)3.3.2 But-1-ene ✓✓ **AND** But-2-ene ✓✓ (4)**Marking criteria**

- Whole structure correct: ✓✓
- Only functional group correct: ✓

(2)

3.4.1 Cracking / elimination ✓ (1)

3.4.2 Ethene ✓ (1)

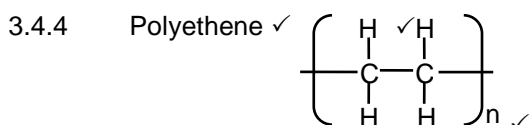
3.4.3 C₄H₁₀ ✓ (1)

(3)

[23]

QUESTION 4

4.1.1 B ✓ (1)

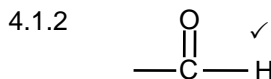

(1)

4.1.3 C_nH_{2n-2} ✓ (1)4.1.4 4-ethyl-5-methylhept-2-yne
OR 4-ethyl-5-methyl-2-heptyne**Marking criteria**

4-ethyl ✓ ; 5-methyl ✓ ; hept-2-yne / 2-heptyne ✓ (3)

(2)

4.1.5 Butan-2-one / 2-butanone ✓✓

4.2.1 Alkanes ✓ (1)

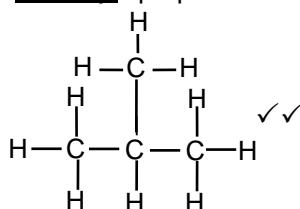
4.2.2 2-methyl✓ propane ✓ **OR** methyl✓propane ✓**Marking criteria for structural formula:**

- Three carbons in longest chain. ✓
- Methyl group on second carbon. ✓

(4)

4.2.3 Chain ✓ (1)

(1)

4.3.1 Haloalkanes / Alkyl halides ✓

(1)

4.3.2 Substitution / halogenation / bromination ✓

(1)

[16]**QUESTION 5**

5.1.1 Ketones ✓

(1)

5.1.2 3,5-dichloro✓-4-methyl✓octane ✓

(3)

5.1.3

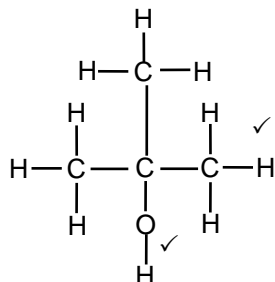
**Marking criteria**

- Functional group (-OH) on second C atom. ✓
- Whole structure correct ✓

(2)

5.2.1 Acts as catalyst. / Increases the rate of reaction. ✓

(1)

5.2.2 Water / H₂O

(1)

5.2.3 mol C : mol H : mol O
 $\frac{40}{12}$ ✓ : $\frac{6,67}{1}$ ✓ : $\frac{53,33}{16}$ ✓5.2.4 $M(\text{CH}_2\text{O}) = 30 \text{ g}\cdot\text{mol}^{-1}$ ✓

Formula-units/Formule-eenhede:

$$\frac{60}{30} = 2 \text{ ✓}$$

Molecular formula/Molekulêre formule: C₂H₄O₂ ✓3,33 : 6,67 : 3,33
1 : 2 : 1 ✓

Empirical formula/Empiriese

formule:

CH₂O ✓

(5)

(3)

5.2.5

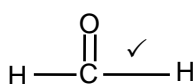

(1)

5.2.6 Methyl ✓methanoate ✓

(2)

[19]**QUESTION 6**

6.1.1 E ✓

(1)

6.1.2 C ✓

(1)

6.1.3 D ✓

(1)

6.2.1 Pent-2✓-yne✓ OR 2-pentyne

(2)

6.2.2

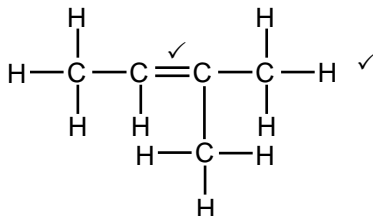
**Marking criteria**

- Whole structure correct: ✓✓
- Only functional group correct: ✓

(2)

6.2.3 2-methylbut-1-ene OR 3-methylbut-1-ene

Marking criteria

- Correct stem i.e. but-1-ene/1-butene. ✓
- Only one type of substituent, methyl, correctly identified. ✓
- Entire name correct. ✓

(3)

6.3.1 Esters ✓

(1)

6.3.2 Sulphuric acid / H₂SO₄ ✓

(1)

6.3.3 Methyl✓ propanoate ✓

(2)

[14]

QUESTION 7

- 7.1.1 A OR D ✓ (1)
 7.1.2 B ✓ (1)
 7.1.3 E ✓ (1)
 7.1.4 D ✓ (1)

7.2.1

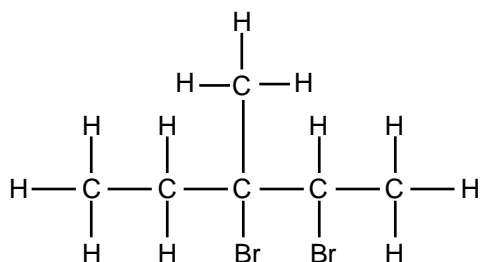
**Marking criteria**

- Five C atoms in longest chain. ✓
- Two Br and one methyl substituents. ✓
- Whole structure correct. ✓

(3)

7.2.2

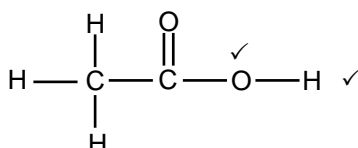
**Marking criteria**

- Whole structure correct: ✓✓
- Only functional group correct: ✓

(2)

7.2.3

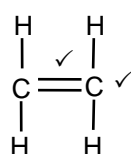
**Marking criteria**

- Whole structure correct: ✓✓
- Only functional group correct: ✓

(2)

7.3.1 Hydrogen gas ✓ (1)

7.3.2 Addition / Hydrogenation ✓ (1)

[13]**QUESTION 8**

8.1 A bond or an atom or a group of atoms ✓ that determine(s) the (physical and chemical) properties of a group of organic compounds. ✓ (2)

8.2.1

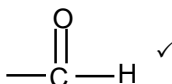

(1)

8.2.2 Carboxyl (group) ✓ (1)

8.3.1 Ketones ✓ (1)

8.3.2

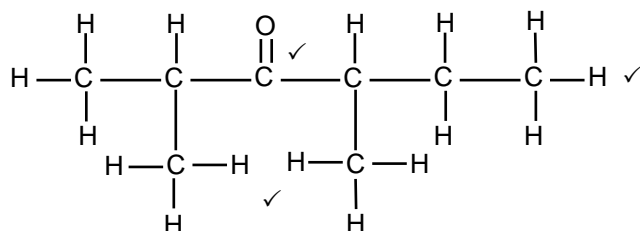

(3)

8.4.1 5-bromo-4-ethyl-2,2-dimethylhexane

Marking criteria

- Correct stem i.e. hexane. ✓
- All substituents (bromo, ethyl and dimethyl) correctly identified. ✓
- IUPAC name completely correct including numbering, sequence, hyphens and commas. ✓

(3)

8.4.2 4-methyl ✓ pent-2-yne ✓ / 4-methyl-2-pentyne (2)**[13]****QUESTION 9**

- 9.1.1 B ✓ (1)
 9.1.2 D OR E ✓ (1)
 9.1.3 F ✓ (1)
 9.2.1 Butanal ✓ (1)

11.3 Compounds with the same molecular formula, ✓ but different positions of the side chain/substituents/functional groups on parent chain. ✓ (2)

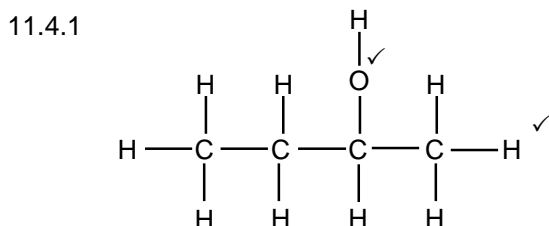
**Marking criteria**

- Whole structure correct: ✓✓
- Only functional group correct: ✓

(2)

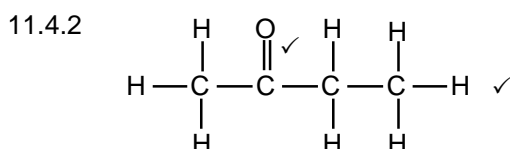
**Marking criteria**

- Whole structure correct: ✓✓
- Only functional group correct: ✓

(2)

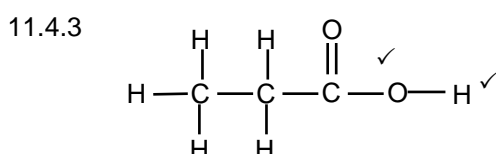
**Marking criteria**

- Whole structure correct: ✓✓
- Only functional group correct: ✓

(2)

[17]**QUESTION 12**

12.1.1 A ✓ (1)

12.1.2 D ✓ (1)

12.1.3 B ✓ (1)

12.1.4 E ✓ (1)

12.1.5 B ✓ (1)

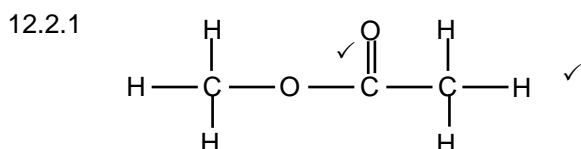
**Marking criteria**

- Whole structure correct: ✓✓
- Only functional group correct: ✓

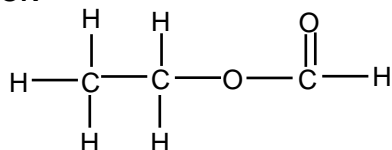
OR

(2)

12.2.2 Methyl ✓ethanoate ✓ **OR** Ethyl ✓methanoate ✓ (2)

12.3.1 A large molecule ✓ composed of smaller monomer units covalently bonded to each other in a repeating pattern. ✓ (2)

12.3.2 Polyethene ✓ (1)

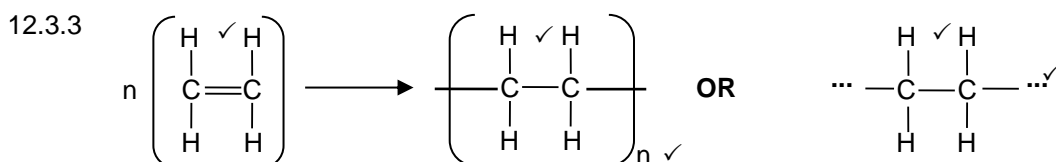

(3)

12.4 Hydrolysis/Substitution ✓ (1)

12.5

- Use concentrated strong base/NaOH/KOH/LiOH ✓
- OR** ethanolic/alcoholic strong base/NaOH/KOH/LiOH. (2)
- Heat strongly ✓

[18]

QUESTION 13

13.1 ANY ONE:

- Alcohol/ethanol is flammable/catches fire easily. ✓
- To heat it evenly. ✓

(1)

13.2.1 Esterification/condensation ✓

(1)

13.2.2 H₂SO₄ ✓

(1)

13.2.3 Esters ✓

(1)

$$13.3 \quad \frac{M(\text{ester})}{M(\text{C}_4\text{H}_8\text{O})} = \frac{144}{72} = 2$$

$$\therefore 2 \times \text{C}_4\text{H}_8\text{O} = \text{C}_8\text{H}_{16}\text{O}_2 \quad \checkmark$$

(2)

13.4 Ethyl ✓ hexanoate ✓

(2)

13.5

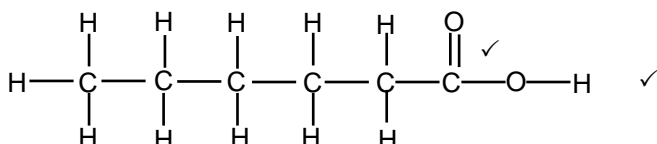
**Marking criteria**

- Whole structure correct: ✓✓
- Only functional group correct: ✓

(2)

[10]

ORGANIC MOLECULES: PHYSICAL PROPERTIES

QUESTION 1

1.1 Alkanes have ONLY single bonds between C atoms. OR Alkanes have NO multiple bonds.

(1)

1.2.1

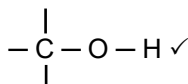

(1)

1.2.2

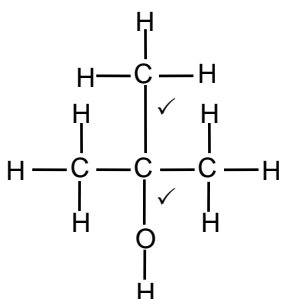
**Marking criteria**

- OH group on second C atom of longest chain. ✓
- Tertiary group consisting of four C atoms with methyl group on 2nd C atom. ✓

(2)

1.3.1

Criteria for investigative question:The dependent and independent variables are stated.

✓

Ask a question about the relationship between the independent and dependent variables.

✓

Examples:

- How does an increase in chain length influence boiling point?
- What is the relationship between chain length and boiling point?

(2)

1.3.2

- Structure:** The chain length increases. ✓
- Intermolecular forces:** Increase in strength of intermolecular. ✓
- Energy:** More energy needed to overcome intermolecular forces. ✓

OR

- Structure:** From propane to methane the chain length decreases. ✓
- Intermolecular forces:** Decrease in strength of intermolecular. ✓
- Energy:** Less energy needed to overcome intermolecular forces. ✓

(3)

1.4

- Between propane molecules are London forces. ✓
- Between propan-1-ol molecules are London forces, dipole-dipole forces and hydrogen bonds. ✓
- Hydrogen bonds are stronger than London forces. ✓

(3)

[12]

QUESTION 2

2.1 C ✓

(1)

2.2.1 Chain length ✓

(1)

2.2.2 Boiling point ✓

(1)

- 2.3 London forces ✓ (1)
- 2.4 Higher than ✓ (1)
- 2.5 Lower than ✓
- Both compounds **D** and **E** have hydrogen bonding between molecules. ✓
 - Compound **D** has one site for hydrogen bonding whilst compound **E** has two sites for hydrogen bonding OR can form dimers. ✓ (4)
 - More energy needed to overcome intermolecular forces in compound **E**. ✓ [9]

QUESTION 3

- 3.1 Saturated ✓
B has ONLY single bonds between C atoms. ✓ OR B has NO multiple bonds. (2)
- 3.2.1 - 42 °C ✓ (1)
- 3.2.2 78 °C ✓ (1)
- 3.3
- Between molecules of **C/propane** are London forces / induced dipole forces. ✓
 - Between molecules of **E/ethanol** are (London forces / induced dipole forces and) hydrogen bonds. ✓
 - Hydrogen bonds / Forces between alcohol molecules are stronger. ✓ (3)
- 3.4 Decrease ✓
From **A** to **D**:
- Chain length increases. ✓
 - Strength of intermolecular forces increases. ✓
 - More energy needed to overcome intermolecular forces. ✓ (4)
- 3.5 Higher than ✓ (1)
- [12]

QUESTION 4

- 4.1 A bond OR an atom OR a group of atoms ✓ that determine(s) the (physical and chemical) properties of a group of organic compounds. ✓ (2)
- 4.2.1 **D** / ethanoic acid ✓
Lowest vapour pressure. ✓ (2)
- 4.2.2 **A** / butane ✓ (1)
- 4.3
- Between molecules of **A** / butane are London forces. ✓
 - Between molecules of **B** / propan-2-one / ketones are dipole-dipole forces ✓ in addition to London forces.
 - Intermolecular forces in A are weaker than those in **B**. ✓ (3)
- 4.4 London forces / induced dipole forces / dipole-dipole forces. ✓
OR A and **B** do not have hydrogen bonding. / **C** and **D** have hydrogen bonding. (1)
- 4.5
- **D** has more sites for hydrogen bonding than **C**. / **D** forms dimers. ✓
 - **D** has stronger intermolecular forces. ✓ (2)

- 4.6
- | | | |
|------------------------------------------------------------------------------------------|-------------------------------------------------------------------------------------------------|--------------------------------------------------------------------------------------------------------------------------------------------------------------------------------------------------------------------------------------------------------------|
| $V(\text{CO}_2) = 4V(\text{C}_4\text{H}_{10})$ $= (4)(8) \checkmark$ $= 32 \text{ cm}^3$ | $V(\text{H}_2\text{O}) = 5V(\text{C}_4\text{H}_{10})$ $= (5)(8) \checkmark$ $= 40 \text{ cm}^3$ | $V(\text{O}_2 \text{ reacted}):$ $V(\text{O}_2) = \left(\frac{13}{2}\right) V(\text{C}_4\text{H}_{10})$ $= \left(\frac{13}{2}\right) (8) \checkmark = 52 \text{ cm}^3$ $V(\text{O}_2 \text{ excess}):$ $V(\text{O}_2) = 60 - 52 \checkmark = 8 \text{ cm}^3$ |
| $V_{\text{tot}} = 32 + 40 + 8 = 80 \text{ cm}^3 \checkmark$ | | |
- (5)
- [16]

QUESTION 5

- 5.1 Temperature at which the vapour pressure equals atmospheric pressure. ✓✓ (2)
- 5.2 The stronger the intermolecular forces, the higher the boiling point. / The boiling point is proportional to the strength of intermolecular forces. ✓
NOTE: NOT DIRECTLY proportional! (1)

- 5.3.1
- Between molecules of **A** / propane are London forces. ✓
 - Between molecules of **B** / propan-2-one are dipole-dipole forces ✓ in addition to London forces.
 - Intermolecular forces in A are weaker than those in **B**. ✓ (3)
- 5.3.2
- Both **C** and **D**: hydrogen bonding ✓
 - **D** has two / more sites for hydrogen bonding. / **D** forms dimers. ✓
 - **D** has stronger intermolecular forces than **C**. ✓ (3)
- 5.4 Liquid ✓ (1)

[10]

QUESTION 6

- 6.1 Temperature ✓ at which the vapour pressure equals atmospheric pressure. ✓ (2)

6.2	Criteria for conclusion:	
	Dependent and independent variables correctly identified.	✓
	Relationship between the independent and dependent variables correctly stated.	✓

Examples:

- Boiling point increases with increase in chain length.
- Boiling point decreases with decrease in chain length.
- Boiling point is proportional to chain length.

NOTE: Boiling point is **NOT DIRECTLY** proportional to chain length. (2)

- 6.3.1 P ✓ (1)

- 6.3.2 R ✓ (1)

- 6.4
- Between alkane molecules are London forces. ✓
 - In addition to London forces and dipole-dipole forces each alcohol molecule has one site for hydrogen bonding. ✓
 - In addition to London forces and dipole-dipole forces each carboxylic acid molecule has two sites for hydrogen bonding. ✓
 - Intermolecular forces in carboxylic acids are stronger than intermolecular forces in alkanes and alcohols. ✓
 - More energy is needed to overcome intermolecular forces in carboxylic acids than in the other two compounds. ✓ (5)

[11]

QUESTION 7

- 7.1 Compounds with the same molecular formula ✓ but different structural formulae. ✓ (2)

- 7.2 Chain ✓ (1)

7.3 **From A to C:**

Structure: Less branched / less compact / larger surface area (over which intermolecular forces act). ✓

Intermolecular forces: Stronger intermolecular forces. ✓

Energy: More energy needed to overcome intermolecular forces. ✓ (3)

- 7.4 A ✓
Lowest boiling point. ✓ (2)

- 7.5 $C_5H_{12} + 8O_2 \rightarrow 5CO_2 + 6H_2O$ ✓ Bal ✓ (3)

[11]

QUESTION 8

8.1.1

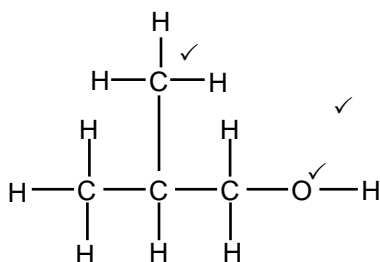
**Marking criteria**

- Functional group ✓
- Methyl substituent ✓
- Whole structure correct: ✓✓✓

- 8.1.2 D ✓ (1)

- 8.1.3 G ✓ (1)

- 8.2.1 Chain length/molecular size/surface area ✓ (1)

- 8.2.2 London forces/dispersion forces/induced-induced dipole ✓ (1)
- 8.3.1 108 °C ✓ (1)
- 8.3.2 **Compare compound F with compounds C and D:**
- Compound **F** has a larger molecular mass/molecular size/surface area than compound **C**. ✓
 - Compound **F** is more branched than compound **D**. ✓
 - Intermolecular forces in compound F are stronger than in compound C and weaker than in compound D. ✓
 - More energy needed to overcome intermolecular forces in compound F than in compound C and less energy needed to overcome intermolecular forces in compound F than in D. (4)

8.4

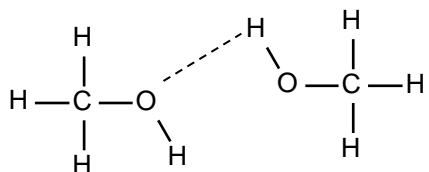

Marking criteria	
At least one structural formula of methanol as shown.	✓
Dotted line drawn from O atom on one molecule to H atom bonded to an O atom in the second molecule. (H atom should be between two O atoms.)	✓

(2)

8.5.1 Esterification/Condensation ✓ (1)

8.5.2

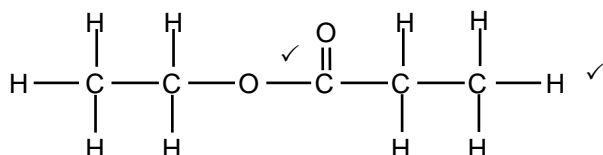
**Marking criteria**

- Functional group ✓
- Whole structure correct: ✓✓

(2)

[17]**QUESTION 9**

- 9.1 The temperature at which the vapour pressure equals atmospheric (external) pressure. ✓✓ (2)
- 9.2 Flammable / Catch fire easily. / Volatile ✓ (1)
- 9.3.1 Use straight chain ✓ primary alcohols ✓ (2)
- 9.3.2
- Structure:** Chain length / more C atoms in chain / molecular size / molecular mass / surface area increases from top to bottom / butan-1-ol to hexan-1-ol. ✓
 - Intermolecular forces:** Intermolecular forces / Van der Waals forces / London forces / dispersion forces increases from top to bottom / butan-1-ol to hexan-1-ol. ✓
 - Energy:** Energy needed to overcome / break intermolecular forces increases from top to bottom / butan-1-ol to hexan-1-ol. ✓ (3)
- 9.4 Remains the same ✓ (1)
- 9.5.1 Functional group / Type of homologous series ✓ (1)
- 9.5.2
- Type of intermolecular forces:** Between molecules of aldehyde / hexanal are dipole-dipole forces. ✓
 - Between molecules of alcohols / hexan-1-ol are (in addition to dipole-dipole forces and London forces) hydrogen bonds. ✓
 - Strength of intermolecular forces:** Dipole-dipole forces are weaker than hydrogen bonds. ✓
OR Hydrogen bonds are stronger than dipole-dipole forces.
 - Energy:** More energy needed to overcome intermolecular forces in hexan-1-ol. ✓ (4)
OR Less energy needed to overcome intermolecular forces in hexanal. ✓ (4)

[14]**QUESTION 10**

- 10.1 **ANY ONE:**
- They have ONLY single bonds between C atoms.
 - They have NO multiple bonds. (1)
- 10.2 The pressure exerted by a vapour in equilibrium with its liquid in a closed system. ✓✓ (2)
- 10.3.1 Increases ✓ (1)
- 10.3.2 Q ✓
- It is the temperature where the vapour pressure of compound **Q** equals atmospheric pressure/is equal to 760 (mmHg). ✓
- OR It is the temperature where the graph intercepts the dotted line. (2)

10.3.3 S ✓

- At a given temperature/reference to any temperature. ✓
- **S** has the lowest vapour pressure. ✓
- Strongest intermolecular forces. ✓

ORHighest energy needed to overcome the intermolecular forces.

(4)

10.4.1

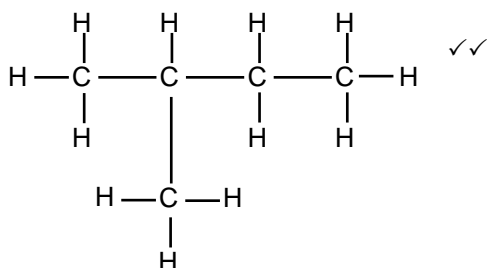

2-methylbutane/methylbutane ✓

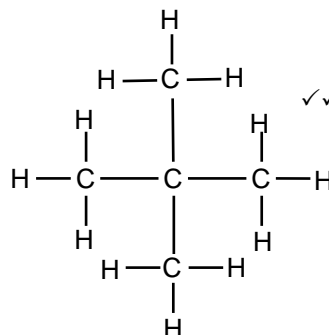
OR

2,2-dimethylpropane/dimethylpropane ✓

(3)

10.4.2 Higher than ✓

(1)

[14]**QUESTION 11**

11.1 150 kPa ✓

(1)

11.2.1 The temperature ✓ at which the vapour pressure equals atmospheric/external pressure. ✓

(2)

11.2.2 55 °C ✓

(1)

11.3.1 Z ✓

(1)

11.3.2 • Carboxylic acids have, in addition to London forces and dipole-dipole forces, two sites for hydrogen bonding between molecules. ✓**OR** Carboxylic acids can form dimers due to strong hydrogen bonding between molecules.• Alcohols have, in addition to London forces and dipole-dipole forces, one site for hydrogen bonding between molecules. ✓• Ketones has, in addition to London forces, dipole-dipole forces between molecules. ✓• Intermolecular forces in ethanoic acid is the strongest./Most energy needed to overcome/break intermolecular forces in ethanoic acid. ✓

(4)

11.3.3 Propanone ✓ **OR** propan-2-one **OR** 2-propanone

(1)

[10]**QUESTION 12**12.1 • **Structure:** The chain length/molecular size/molecular mass/ surface area increases. ✓• **Intermolecular forces:** Increase in strength of intermolecular forces. ✓• **Energy:** More energy needed to overcome intermolecular forces. ✓**OR**• **Structure:** From 4 C atoms to 1 C atom/bottom to top the chain length/molecular size/molecular mass/surface area decreases. ✓• **Intermolecular forces:** Decrease in strength of intermolecular forces. ✓• **Energy:** Less energy needed to overcome intermolecular forces. ✓

(3)

12.2

• Alkanes have London forces. ✓

• Alcohols have hydrogen bonding (in addition to London forces and dipole dipole forces). ✓

• Hydrogen bonding are stronger intermolecular forces than London. ✓

OR More energy needed to overcome intermolecular forces in alcohols

• Alcohols have higher boiling points than alkanes. ✓

(4)

12.3 Decrease ✓

(1)

12.4 Lower than ✓

2-methylpropane is more branched/has a smaller surface area than butane/chain isomer. ✓

OR Butane/chain isomer is less branched /has larger surface area than 2-methylpropane.

(2)

[10]

QUESTION 13

13.1 The temperature at which the vapour pressure of a substance equals atmospheric/external pressure. ✓✓ (2)

13.2.1 Carboxyl group ✓ (1)

13.2.2 Propanoic acid ✓ (1)

13.2.3 ✓ ✓

Marking criteria
• Whole structure correct: ✓✓
• Only functional group correct: ✓

 (2)

13.3 A ✓
Lowest boiling point./Shortest chain length. ✓ (2)

13.4.1 The same molecular mass/molecular size. ✓ (1)

13.4.2 Primary ✓
-OH group is bonded to a C atom bonded to one other C atom. ✓ (2)

13.4.3

- Both compounds X and B have (in addition to London forces and dipole-dipole forces) hydrogen bonding. ✓
- Compound X/CH₃CH₂CH₂OH/propan-1-ol/alcohol has one site for hydrogen bonding and compound B/ethanoic acid/carboxylic acid has two/more sites for hydrogen bonding **OR** B/ethanoic acid/carboxylic acid has two/more sites for hydrogen bonding. ✓
- Intermolecular forces in compound B/ethanoic acid/carboxylic acid are stronger than intermolecular forces in compound X/CH₃CH₂CH₂OH/ propan-1-ol/alcohol. ✓ **OR** Intermolecular forces in compound X/CH₃CH₂CH₂OH/ propan-1-ol/alcohol are weaker than intermolecular forces in compound B/ethanoic acid/carboxylic acid.
- More energy is needed to overcome intermolecular forces in compound B/ethanoic acid/carboxylic acid than in compound X/CH₃CH₂CH₂OH/ propan-1-ol/alcohol. ✓ **OR** Less energy is needed to overcome intermolecular forces in compound X/CH₃CH₂CH₂OH/propan-1-ol/alcohol than in compound B/ethanoic acid/carboxylic acid. (4)

[15]

ORGANIC MOLECULES: ORGANIC REACTIONS**QUESTION 1**

1.1.1 Substitution / chlorination / halogenation ✓ (1)

1.1.2 Substitution / hydrolysis ✓ (1)

1.2.1 Hydrogenation ✓ (1)

1.2.2 (3)

1.3 ✓ ✓

Marking criteria
• Whole structure correct: ✓✓
• Only functional group correct: ✓

 (2)

1.4.1 Esterification ✓ (1)

1.4.2 Concentrated H₂SO₄ / sulphuric acid ✓ (1)

1.4.3

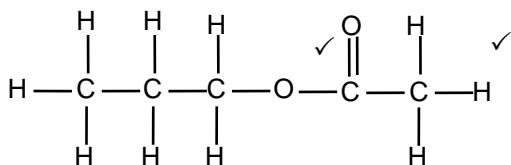
**Marking criteria**

- Whole structure correct: ✓✓
- Only functional group correct: ✓

(2)

1.4.4

Propyl ✓ ethanoate ✓

(2)

1.5

Sulphuric acid / H₂SO₄ ✓

(1)

[15]**QUESTION 2**

2.1

Unsaturated ✓

Contains a double bond / multiple bond between C atoms. ✓

(2)

2.2.1

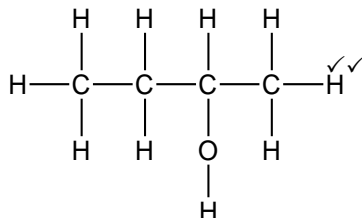

(2)

2.2.2

Addition / hydration ✓

(1)

2.3.1

2-chloro ✓ butane ✓

(2)

2.3.2

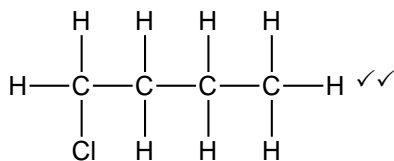

(1)

2.4.1

H₂O **OR** dilute NaOH / KOH ✓ AND mild heat ✓

(1)

2.4.2

Substitution / hydrolysis ✓

(1)

2.4.3

C₄H₉Cl + NaOH ✓ → C₄H₁₀O + NaCl ✓ bal. ✓

OR C₄H₉Cl + H₂O ✓ → C₄H₁₀O + HCl ✓ bal. ✓

(3)

[15]**QUESTION 3**

3.1.1

Hydrolysis ✓

(1)

3.1.2

(Mild) heat ✓ AND dilute (strong) base/aqueous base ✓

(2)

3.1.3

Ethanol ✓

(1)

3.2.2

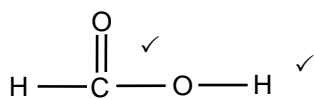
**Marking criteria**

- Functional group correct: ✓
- Whole structure correct: ✓✓

(2)

3.2.3

Ethyl ✓ methanoate ✓

(2)

[9]**QUESTION 4**

4.1.1

Esterification / Condensation ✓

(1)

4.1.2

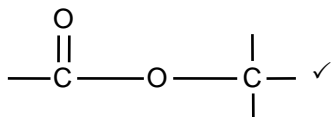

(1)

4.1.3

Propanoic acid ✓

(1)

4.1.4

Dehydration / elimination ✓

(1)

4.1.5

(Concentrated) H₂SO₄ / sulphuric acid / H₃PO₄ / phosphoric acid ✓

(1)

4.1.6

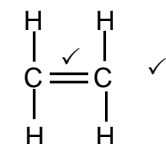
**Marking criteria**

- Only functional group correct: ✓
- Whole structure correct: ✓✓

(2)

4.2.1

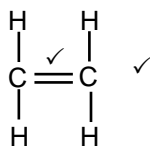

4.2.2

Addition ✓

Marking criteria

- Only functional group correct: ✓
- Whole structure correct: ✓✓

(2)

(1)

[10]**QUESTION 5**

5.1.1 Addition ✓

(1)

5.1.2 Polyethene ✓

(1)

5.2.1 Chloroethane ✓

(2)

5.2.2 Hydrohalogenation/hydrochlorination ✓

(1)

5.3.1

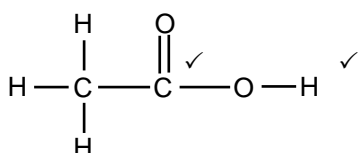

5.3.2 HCl / hydrogen chloride ✓

(2)

5.4.1 Saturated ✓ There are no double / multiple bonds between C atoms. ✓

(1)

5.4.2 H₂ / hydrogen gas ✓

(2)

5.4.3 2C₂H₆ + 7O₂ ✓ → 4CO₂ + 6H₂O ✓ Bal. ✓

(1)

[14]**Marking criteria**

- Only functional group correct: ✓
- Whole structure correct: ✓✓

(2)

QUESTION 6

6.1.1 Addition / Hydrogenation ✓

(1)

6.1.2 Elimination / Dehydrohalogenation / Dehydrobromination ✓

(1)

6.1.3 Substitution / Halogenation / Bromination ✓

(1)

6.2.1 Pt / platinum ✓

(1)

6.2.2 H₂SO₄ / sulphuric acid ✓

(1)

6.2.3 Hydration ✓

(1)

6.2.4 2-bromopropane ✓

(2)

6.3

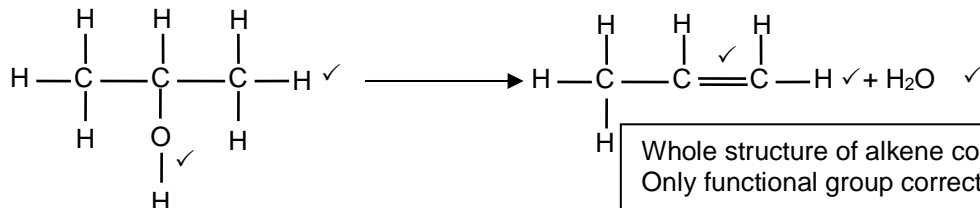

Whole structure of alkene correct: ✓✓
Only functional group correct: ✓

(5)

6.4 Higher temperature ✓

(2)

Concentrated base ✓

[15]**QUESTION 7**

7.1.1 High temperature / heat / high energy / high pressure ✓

(1)

7.1.2 C₆H₁₂ ✓

(1)

7.1.3 Alkenes ✓

(1)

7.2 X / C₆H₁₂ / Alkene ✓**OPTION 1**

- X has a double bond. / X is unsaturated. ✓
- X can undergo addition. ✓
- X will react without light / heat. ✓

OPTION 2

- Butane is an alkane OR butane is saturated. ✓
- Butane can only undergo substitution. ✓
- Butane will only react in the presence of light or heat. ✓

(4)

QUESTION 13

13.1.1 (A series of organic) compounds that can be described by the same general formula/functional group. ✓✓
OR (A series of organic) compounds in which one member differs from the next by a CH₂ group. (2)

13.1.2 Substitution/halogenation/bromination ✓ (1)

13.1.3 HBr ✓ (1)

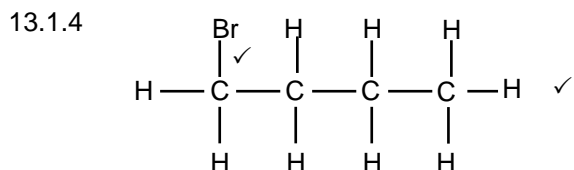
**Marking criteria**

- Br on first C atom: ✓
- Whole structure correct: ✓✓

(2)

13.1.5 C₅H₁₂ + 8O₂ ✓ → 5CO₂ + 6H₂O ✓ Bal ✓ (3)

13.1.6 The (chemical) process in which longer chain hydrocarbons/longer chain alkanes are broken down to shorter/more useful hydrocarbons/molecules/ chains/alkanes and alkenes. ✓✓ (2)

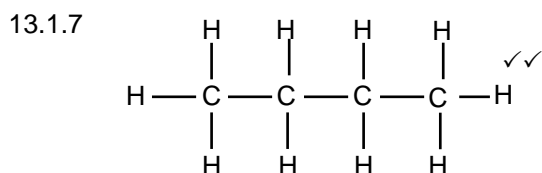
**Marking guidelines**

- One or more H atoms omitted: - 1
- Condensed or semi-structural formula: - 1

(2)

13.2.1 Butan-2-ol ✓✓ **OR** 2-butanol ✓✓ (2)

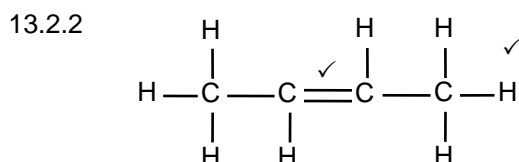
**Marking criteria:**

- Whole structure of alkene/haloalkane correct: ✓✓
- Only functional group correct: ✓

(2)

[17]**REACTION RATE AND ENERGY IN CHEMICAL REACTIONS****QUESTION 1**

1.1 Change in concentration of products / reactants ✓ per unit time. ✓ (2)

1.2.1 Temperature ✓ (1)

1.2.2 Rate of reaction / Volume of gas formed per unit time ✓ (1)

1.3

- Larger mass / amount / surface area. ✓
- More effective collisions per unit time. / More particles collide with sufficient kinetic energy & correct orientation per unit time. ✓✓ (3)

1.4		Marking criteria	
Compare Exp.1 with Exp. 2:	Reaction in <u>exp. 1</u> is faster than in <u>exp. 2</u> due to <u>higher acid concentration</u> .	✓	
	Therefore the <u>gradient</u> of the graph representing <u>exp. 1</u> is <u>greater / steeper</u> than that of <u>exp. 2</u> .	✓	
Compare Exp. 1 with Exp 3 & 4:	The reaction in <u>exp. 3</u> is faster than that in <u>exp. 1</u> due to the <u>higher temperature</u> .	✓	
	The reaction in <u>exp. 4</u> is faster than that in <u>exp. 1</u> due to the <u>higher temperature / larger surface area</u> . OR Graph <u>A</u> represents <u>exp. 4</u> due to the <u>greater mass</u> of CaCO ₃ - greater yield of CO ₂ at a faster rate.	✓	
	Therefore the <u>gradient</u> of the graphs of <u>exp. 3 & 4</u> are <u>greater/steeper</u> than that of <u>exp. 1</u> .	✓	
Final answer	C	✓	

(6)

1.5 $n(\text{CO}_2) = \frac{V}{V_m} = \frac{4,5}{25,7} \checkmark = 0,18 \text{ mol}$
 $n(\text{CaCO}_3) = n(\text{CO}_2) = 0,18 \text{ mol} \checkmark$
 $n(\text{CaCO}_3) = \frac{m}{M} \therefore 0,18 = \frac{m}{100} \checkmark \therefore m(\text{CaCO}_3) = 18 \text{ g}$
 $m(\text{CaCO}_3) \text{ not reacted: } 25 - 18 \checkmark = 7,00 \text{ g} \checkmark$

(5)
[18]**QUESTION 2**2.1 Exothermic \checkmark Temperature increases during reaction. / $T_i < T_f \checkmark$ (2)2.2 Larger surface area in experiment 2. \checkmark (1)2.3 More than one independent variable. \checkmark **OR** Different concentrations and state of division. (1)2.4 Faster than \checkmark
A catalyst is used in experiment 5. \checkmark

- A catalyst provides an alternative pathway of lower activation energy. \checkmark
- More molecules have sufficient kinetic energy. \checkmark
- More effective collisions per unit time. \checkmark

(5)

2.5 $n(\text{Zn}) = \frac{m}{M} \checkmark = \frac{1,2}{65} \checkmark = 0,018 \text{ mol}$
 $n(\text{HCl})_{\text{reacted}} = 2n(\text{Zn}) = 2(0,018) = 0,037 \text{ mol} \checkmark$
 $\text{Rate} = \frac{\Delta n}{\Delta t} = \frac{0,037 \checkmark}{8 \checkmark} = 4,63 \times 10^{-3} \text{ mol} \cdot \text{s}^{-1} \checkmark$ (6)
[15]

QUESTION 33.1 Exothermic \checkmark $\Delta H < 0$ / Energy is released. \checkmark (2)

3.2	OPTION 1	OPTION 2
3.2.1	$n(\text{HCl}) = cV$ $= (1,5) \checkmark (30 \times 10^{-3}) \checkmark = 0,045 \text{ mol}$ $\text{Ave rate} = -\frac{\Delta n}{\Delta t} = -\frac{0 - 45 \checkmark}{60 - 1 \checkmark}$ $= 7,5 \times 10^{-4} \text{ mol} \cdot \text{s}^{-1} \checkmark$	$\text{Ave rate} = -\frac{\Delta n}{\Delta t} = -\frac{0 - 1,5 \checkmark}{60 - 1 \checkmark}$ $= 0,025 \text{ mol} \cdot \text{dm}^{-3} \cdot \text{s}^{-1}$ $\therefore \text{average rate} = (0,025)(30 \times 10^{-3}) \checkmark \checkmark$ $= 7,5 \times 10^{-4} (\text{mol} \cdot \text{s}^{-1}) \checkmark$

(5)
3.2.2(a) Increases \checkmark

- The reaction is exothermic, resulting in an increase in temperature. \checkmark
- More molecules have sufficient kinetic energy. \checkmark
- More effective collisions per unit time. \checkmark

(4)3.2.2(b) Decreases \checkmark
Concentration of acid decreases. \checkmark **OR** The surface area of magnesium decreases. (2)3.3 **ANY TWO**

- Higher temperature \checkmark
- Larger surface area/state of division/contact area of Mg. / Use Mg powder. \checkmark
- Addition of a catalyst.

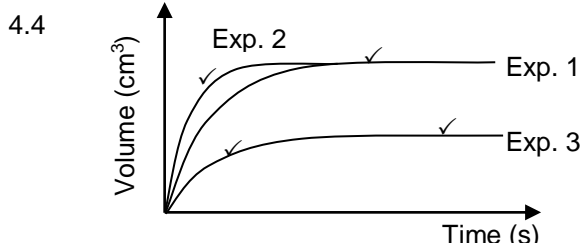
(2)
[15]**QUESTION 4**4.1 Time: Stop watch \checkmark Volume: Gas syringe / burette \checkmark (2)4.2.1 $t_1 \checkmark$ (1)4.2.2 $t_3 \checkmark$ (1)4.3 Between t_1 and $t_2 \checkmark$ (1)

Marking criteria		
Exp. 2	Initial gradient higher than that of Exp.1.	\checkmark
	Curve reaches same constant volume as for Exp. 1 (but earlier).	\checkmark
Exp.3	Initial gradient lower than that of Exp.1.	\checkmark
	Curve reaches a smaller constant volume as for Exp. 1 (later stage).	\checkmark

(4)

4.5.1

OPTION 1	OPTION 2
$n(\text{HCl}) = cV = (0,1)(100 \times 10^{-3}) \checkmark$ $= 0,01 \text{ mol}$	$n(\text{HCl}) = cV = (0,1)(100 \times 10^{-3}) \checkmark = 0,01 \text{ mol}$
$n(\text{Zn reacted}) = \frac{1}{2}n(\text{HCl}) = \frac{1}{2}(0,01) \checkmark$ $= 5 \times 10^{-3} \text{ mol}$	$n(\text{Zn reacted}) = \frac{1}{2}n(\text{HCl}) = \frac{1}{2}(0,01) \checkmark$ $= 5 \times 10^{-3} \text{ mol}$
$m(\text{Zn reacted}) = (5 \times 10^{-3})(65) \checkmark = 0,325 \text{ g}$	$n(\text{Zn})_i = \frac{m}{M} = \frac{0,8}{65} \checkmark = 1,23 \times 10^{-2} \text{ mol}$
$m(\text{Zn}_f) = 0,8 - 0,325 \checkmark$ $= 0,48 \text{ g} \checkmark (0,475 \text{ g})$	$n(\text{Zn})_f = 1,23 \times 10^{-2} - 5 \times 10^{-3} \checkmark = 7,3 \times 10^{-3} \text{ mol}$
	$m(\text{Zn}) = nM = (7,3 \times 10^{-3})(65) = 0,47 \text{ g} \checkmark$

(5)

(1)

[15]

4.5.2 Smaller than \checkmark **QUESTION 5**5.1 **ANY TWO:**Increase temperature. \checkmark ; Increase concentration of acid. \checkmark ; Add a catalyst. (2)5.2 Change in concentration of products / reactants \checkmark per unit time. \checkmark (2)

5.3.1

$$\begin{aligned} \text{average rate / gemiddelde tempo} &= -\frac{\Delta c}{\Delta t} \\ &= -\frac{(1,45 - 1,90) \checkmark}{(15 - 0) \checkmark} \\ &= 0,03 \text{ (mol} \cdot \text{dm}^{-3}) \cdot \text{min}^{-1} \checkmark \end{aligned}$$

(3)

5.3.2

Graph of concentration versus time
Grafiek van konsentrasie teenoor tyd

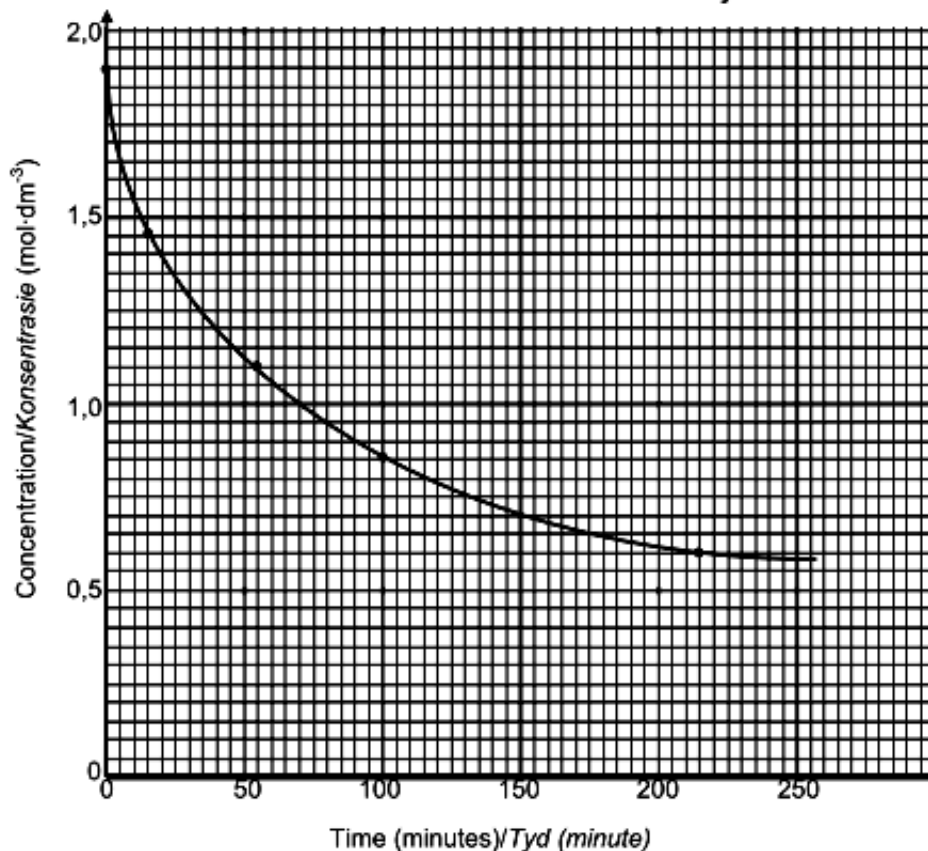
**Marking criteria/Nasienriglyne**Four points correctly plotted./Vier punte korrek gestip. $\checkmark\checkmark$ Curve drawn as shown./Kurwe getrek soos getoon. \checkmark

(3)

5.3.3 1,15 to 1,25 mol·dm⁻³ \checkmark (1)5.3.4 • Concentration of reactants decreases. \checkmark • Less particles per unit volume. \checkmark • Less effective collisions per unit time. \checkmark (3)

5.3.5

OPTION 1/OPSIE 1	OPTION 2/OPSIE 2
Mol initially/begin: $n(\text{HCl}) = cV$ ✓ $= (1,9)(60 \times 10^{-3})$ ✓ $= 0,11 \text{ mol (0,114)}$	$\Delta c(\text{HCl}) = 0,6 - 1,9$ ✓ $= -1,3$ $= 1,3 \text{ mol} \cdot \text{dm}^{-3}$
Mol final/finaal: $n(\text{HCl}) = cV$ ✓ $= (0,6)(60 \times 10^{-3})$ ✓ $= 0,04 \text{ mol (0,036)}$	$\Delta n(\text{HCl}) = \Delta cV$ ✓ $= (1,3)(60 \times 10^{-3})$ ✓ $= 0,08 \text{ mol (0,078)}$
$\Delta n(\text{HCl}) = 0,04 - 0,11$ ✓ $= -0,07 \text{ mol (0,078 mol)}$ $\Delta n(\text{HCl}) = 0,07 \text{ mol (0,078)}$	$n(\text{formed/gevorm}) = n(\text{reacted/reageer})$ $n(\text{CH}_3\text{Cl}) = n(\text{HCl})$ ✓ $= 0,08 \text{ mol}$
$n(\text{formed/gevorm}) = n(\text{reacted/reageer})$ $n(\text{CH}_3\text{Cl}) = n(\text{HCl})$ ✓ $= 0,07 \text{ mol}$	$m(\text{CH}_3\text{Cl}) = nM$ ✓ $= (0,08)(50,5)$ ✓ $= 4 \text{ g}$ ✓
$m(\text{CH}_3\text{Cl}) = nM$ ✓ $= (0,07)(50,5)$ ✓ $= 3,54 \text{ g}$ ✓	Accept range/Aanvaar gebied: 3,54 – 4,0 g
Accept range/Aanvaar gebied: 3,54 – 4,0 g	

(5)
[19]

QUESTION 6

6.1 ANY TWO:

Temperature of reaction mixture ✓; Addition of a catalyst ✓; Concentration of reactants

(2)

6.2 Sulphur / S ✓

(1)

6.3 Water is used to dilute/change the concentration of the $\text{Na}_2\text{S}_2\text{O}_3(\text{aq})$ ✓

(1)

6.4

Criteria for investigative question:	
The <u>dependent</u> and <u>independent</u> variables are stated correctly.	✓
Asks a question about the relationship between <u>dependent</u> and <u>independent</u> variables.	✓

Dependent variable: reaction rate**Independent variable:** concentration**Examples:** What is the relationship between concentration and reaction rate?How does the reaction rate change with change in concentration?

(2)

6.5 A ✓

(1)

6.6 **Experiment B:**

- The concentration of $\text{Na}_2\text{S}_2\text{O}_3(\text{aq})$ is higher. / More $\text{Na}_2\text{S}_2\text{O}_3$ particles per unit volume. ✓
- More particles with correct orientation. ✓
- More effective collisions per unit time. ✓

(3)

6.7

OPTION 1	OPTION 2	OPTION 3
$c = \frac{m}{MV}$ ✓ $= \frac{62,5}{\sqrt{(158)(0,25)}}$ ✓ $= 1,58 \text{ mol} \cdot \text{dm}^{-3}$	$n = \frac{m}{M}$ ✓ $= \frac{62,5}{158}$ ✓ $= 0,396 \text{ mol}$ $c = \frac{n}{V}$ $= \frac{0,396}{0,25}$ ✓ $= 1,58 \text{ mol} \cdot \text{dm}^{-3}$	$250 \text{ cm}^3 \dots\dots 62,5 \text{ g}$ $10 \text{ cm}^3 \dots\dots \frac{10}{250} \times 62,5$ ✓ $\therefore m(\text{Na}_2\text{S}_2\text{O}_3 \text{ in D}) = 2,5 \text{ g}$ $n(\text{Na}_2\text{S}_2\text{O}_3 \text{ in D}) = \frac{m}{M}$ $= \frac{2,5}{158}$ ✓ $= 0,0158 \text{ mol}$
$n(\text{Na}_2\text{S}_2\text{O}_3 \text{ in D}) = cV = (1,58)(0,01)$ ✓ $= 0,0158 \text{ mol}$		$n(\text{S}) = (\text{Na}_2\text{S}_2\text{O}_3)$ ✓ = 0,0158 $n = \frac{m}{M} \therefore 0,0158 = \frac{m}{32}$ ✓ $\therefore m = 0,51 \text{ g}$ ✓

(7)
[17]

QUESTION 7

7.1.1 The minimum energy needed for a reaction to take place. ✓✓ (2)

7.1.2

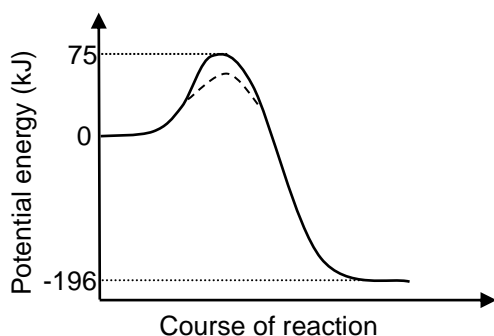

Marking criteria	
Shape of curve for exothermic reaction as shown.	✓
Energy of activated complex shown as 75 kJ in line with the peak.	✓
Energy of products shown as -196 kJ below the zero.	✓
IF: Wrong shape, e.g. straight line.	0/3

(3)

7.1.3 **Marking criteria**

- Dotted line (---) on graph in Q7.1.2 showing lower energy for activated complex. ✓
- Dotted curve starts at/above energy of reactants and ends at/above energy of products on the inside of the original curve. ✓

(2)

7.1.4

- A catalyst provides an alternative pathway of lower activation energy. ✓
- More molecules have sufficient kinetic energy. ✓
- More effective collisions per unit time. ✓

(3)

7.2.1

$$\text{Ave rate} = \frac{\Delta V}{\Delta t} = \frac{52 - 16}{40 - 10} \checkmark = 1,2 \text{ (dm}^3 \cdot \text{s}^{-1}) \checkmark$$

(3)

7.2.2

OPTION 1	OPTION 2	OPTION 3
$n(\text{O}_2) = \frac{V}{V_m} = \frac{60}{24} \checkmark$ $= 2,5 \text{ mol}$ $n(\text{H}_2\text{O}_2) = 2n(\text{O}_2) = 2(2,5) \checkmark$ $= 5 \text{ mol}$ $n(\text{H}_2\text{O}_2) = \frac{m}{M} \therefore 5 = \frac{m}{34} \checkmark$ $\therefore m = 170 \text{ g} \checkmark$	$24 \text{ dm}^3 : 1 \text{ mol}$ $60 \text{ dm}^3 : 2,5 \text{ mol} \checkmark$ $n(\text{H}_2\text{O}_2) = 2n(\text{O}_2)$ $= 2(2,5) \checkmark$ $= 5 \text{ mol}$ $34 \text{ g} \checkmark : 1 \text{ mol}$ $x : 5 \text{ mol}$ $x = 170 \text{ g} \checkmark$	$n(\text{O}_2) = \frac{V}{V_m} = \frac{60}{24} \checkmark = 2,5 \text{ mol}$ $n(\text{O}_2) = \frac{m}{M} \therefore 2,5 = \frac{m}{32}$ $\checkmark \therefore m = 80 \text{ g}$ $2(34) \text{ g} \checkmark \text{ H}_2\text{O}_2 \dots\dots\dots 32 \text{ g O}_2$ $x \text{ g H}_2\text{O}_2 \dots\dots\dots 80 \text{ g O}_2$ $m(\text{H}_2\text{O}_2) = 170 \text{ g} \checkmark$

(4)

7.2.3 Equal to ✓

(1)

7.3.1 Q ✓

(1)

7.3.2 P ✓

(1)

[20]**QUESTION 8**

8.1.1 To measure volume of gas/oxygen produced. ✓ (1)

8.1.2 Catalyst/Speeds up the reaction./Increases reaction rate. ✓ (1)

8.2 No more gas/bubbles produced. ✓ (1)

8.3 CuO/Copper(II) oxide/catalyst ✓ (1)

8.4

- A catalyst provides an alternative pathway of lower activation energy. ✓
- More molecules have sufficient/enough kinetic energy. ✓
- **OR** More molecules have kinetic energy equal to or greater than the activation energy.
- More effective collisions per unit time./Frequency of effective collisions increases. ✓ (3)

8.5.1 Released ✓ Products at lower energy than reactant./Reaction is exothermic/ $\Delta H < 0$ ✓ (2)

8.5.2 B ✓ (1)

8.6

$$n(\text{O}_2)_{\text{produced}} = \frac{V}{V_m} = \frac{0,4}{25} \checkmark = 0,016 \text{ mol} \therefore n(\text{H}_2\text{O}_2)_{\text{used}} = 2(0,016) \checkmark = 0,032 \text{ mol}$$

$$[\text{H}_2\text{O}_2] = \frac{n}{V} = \frac{0,032}{0,05} \checkmark = 0,64 \text{ mol} \cdot \text{dm}^{-3} \therefore \text{Rate} = -\frac{\Delta c}{\Delta t} = -\frac{0 - 0,64}{5,8 - 0} \checkmark = 0,11 \text{ (mol} \cdot \text{dm}^{-3} \cdot \text{min}^{-1}) \checkmark$$

(6)

[16]

QUESTION 99.1 **ANY TWO**

- Increase temperature of HCl. ✓
- Add a catalyst. ✓
- Increase the concentration of HCl.
- Increase the state of division of CuCO₃.

(2)

9.2 Accepted range: 42 s to 50 s ✓

(1)

9.3.1
$$\text{average} = -\frac{\Delta m}{\Delta t} = -\frac{(169,76 - 170,00)}{(20 - 0)} = 0,012 (\text{g} \cdot \text{s}^{-1}) \checkmark$$

If answer is negative (minus 1 mark)

(3)

9.3.2 Pure sample: $m(\text{CO}_2)_{\text{formed}} = 170,00 - 169,73 \checkmark = 0,27 \text{ g}$

Impure sample: $m(\text{CO}_2)_{\text{formed}} = 170,00 - 169,78 \checkmark = 0,22 \text{ g}$

$$\% \text{Purity} = \frac{0,22}{0,27} \times 100 \checkmark = 81,48\% \checkmark$$

(4)

9.3.3
$$n(\text{CO}_2)_{\text{formed}} = \frac{m}{M} = \frac{0,27}{44} = 6,13 \times 10^{-3} \text{ mol}$$

$$n(\text{CO}_2) = \frac{V}{V_m} \therefore 6,13 \times 10^{-3} = \frac{V}{22,4} \therefore V = 0,137 \text{ dm}^3 \checkmark$$

(3)

9.4

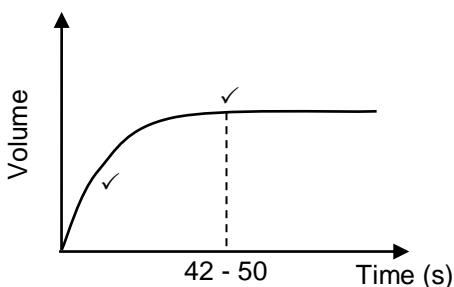
**Marking criteria for sketch graph:**

Graph drawn from origin with decreasing gradient. ✓

Constant volume after (42 -50) s. **or** graph stops at (42 -50) s. ✓

If no labels on axes: minus 1.

(2)

[15]**QUESTION 10**10.1 Change in concentration of products/reactants per (unit) time. ✓✓

(2)

10.2 **Marking criteria**

Independent (concentration) and dependent (reaction rate) variables correctly identified. ✓

Ask a question about the relationship between the independent and dependent variables. ✓

Examples:

- What is the relationship between concentration and reaction rate?
- How does the reaction rate change when the concentration changes/increases/decreases?

IF the answer to the question is "YES" or "NO": Max. 1 mark**Examples:** Does reaction rate increase with increase in concentration?

Is there a relationship between reaction rate and concentration?

(2)

10.3 Q ✓

- Reaction **I** has the lower (HCl) concentration. ✓

- Smaller/less steep gradient. ✓

OR Take longer to complete./Slower reaction rate./Produce less product per unit time./Take longer for the maximum volume of gas to form.

(3)

10.4

OPTION 1	OPTION 2
$\text{Ave rate} = \frac{\Delta V}{\Delta t} \therefore 15 = \frac{\Delta V}{30(-0)} \checkmark$ $V(\text{H}_2)_{\text{produced}} = 450 \text{ cm}^3$ $n(\text{H}_2)_{\text{produced}} = \frac{V}{V_m} = \frac{450}{24\,000} \checkmark$ $= 0,0188 \text{ mol}$	$\text{Ave rate} = \frac{\Delta V}{\Delta t} \therefore 15 \times 10^{-3} = \frac{\Delta V}{30(-0)} \checkmark$ $V(\text{H}_2)_{\text{produced}} = 0,45 \text{ dm}^3$ $n(\text{H}_2)_{\text{produced}} = \frac{V}{V_m} = \frac{0,45}{24} \checkmark$ $= 0,0188 \text{ mol}$
$n(\text{Zn}) = n(\text{H}_2) = 0,0188 \text{ mol} \checkmark$	
$n(\text{Zn})_{\text{used}} = \frac{m}{M} \therefore 0,0188 = \frac{m}{65} \checkmark \therefore m(\text{Zn}) = 1,22 \text{ g} \checkmark$	

(5)

10.5.1 Equal to ✓

(1)

10.5.2 Equal to ✓

(1)

- 10.6
- At higher temperature the (average) kinetic energy of particles is higher. ✓
 - More molecules have sufficient/enough kinetic energy. ✓
 - **OR** More molecules have kinetic energy equal to or greater than the activation energy.
 - More effective collisions per unit time. ✓

(3)

[17]

QUESTION 11

11.1 Change in concentration ✓ of a reactant/product per unit time. ✓

(2)

11.2 Greater than ✓

(1)

11.3 **Graph of average reaction rate versus volume of Na₂S₂O₃(aq)**

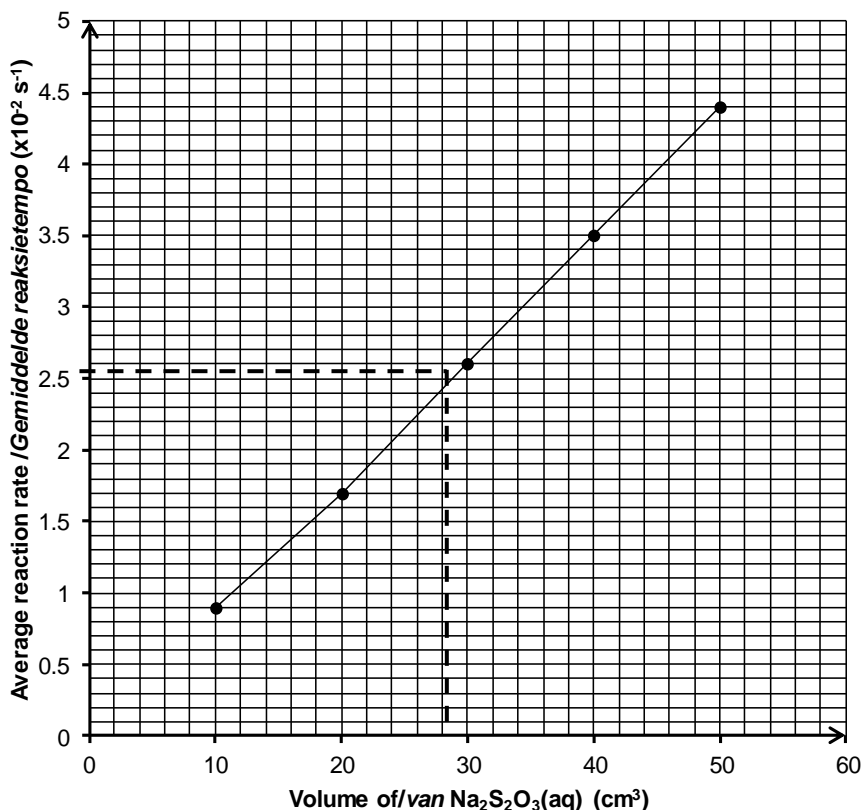

Marking criteria

- Any 3 points correctly plotted. ✓
- All (5) points correctly plotted. ✓
- Straight line drawn. ✓

(3)

11.4.1 **Marking criteria**

- y axis/y-as: 2,5 x 10⁻² s⁻¹ ✓
- Dotted line drawn from the y-axis to the x-axis as shown. ✓
- V = 28 to 30 cm³ ✓

(3)

11.4.2	Criteria for conclusion	
	Dependent and independent variables correctly identified.	✓
	Relationship between the independent and dependent variables correctly stated.	✓

Examples:

- Reaction rate of reaction increases with an increase in concentration/volume of sodium thiosulphate.
- Reaction rate decreases with a decrease in concentration/volume of sodium thiosulphate.
- Reaction rate is (directly) proportional to concentration/volume of sodium thiosulphate. (2)

- 11.5
- More Na₂S₂O₃ particles per unit volume. ✓
 - More effective collisions per unit time./Higher frequency of effective collisions. ✓
 - Increase in reaction rate. ✓ (3)

11.6

$$n(\text{S})_{\text{produced}} = \frac{m}{M} = \frac{1,62}{32} = 0,05 \text{ mol}$$

$$n(\text{Na}_2\text{S}_2\text{O}_3) = n(\text{S}) = 0,05 \text{ mol} \quad \checkmark$$

$$n(\text{Na}_2\text{S}_2\text{O}_3) = \frac{m}{M} \quad \therefore 0,05 = \frac{m}{158} \quad \checkmark$$

$$\therefore m(\text{Na}_2\text{S}_2\text{O}_3) = 7,90 \text{ g} \quad \checkmark$$

[18]

QUESTION 12

- 12.1 Change in concentration of products/reactants per (unit) time. ✓✓ (2)

- 12.2.1 Surface area/State of division ✓ (1)

12.2.2 ANY ONE:

- Amount/mass of magnesium ✓
- Concentration of HCl/acid
- (Initial) temperature/ (1)

12.3.1

<p>OPTION 1</p> $\Delta m(\text{Mg}) = 2,6 - 0,2 \quad \checkmark = 2,4 \text{ g}$ $n(\text{Mg}_{\text{used}}) = \frac{m}{M} = \frac{2,4}{24} \quad \checkmark = 0,1 \text{ mol}$ $n(\text{H}_2) = n(\text{Mg}) = 0,1 \text{ mol} \quad \checkmark$ $V(\text{H}_2) = nV_m = (0,1)(25) \quad \checkmark = 2,5 \text{ dm}^3 \quad \checkmark$	<p>OPTION 2</p> $n(\text{Mg})_{t=2\text{s}} = \frac{m}{M} = \frac{2,6}{24} \quad \checkmark = 0,1083 \text{ mol}$ $n(\text{Mg})_{t=10\text{s}} = \frac{0,2}{24} = 0,0083 \text{ mol}$ $\Delta n(\text{Mg}) = 0,1083 - 0,0083 \quad \checkmark = 0,1 \text{ mol}$ $n(\text{H}_2) = n(\text{Mg}) = 0,1 \text{ mol} \quad \checkmark$ $V(\text{H}_2) = nV_m = (0,1)(25) \quad \checkmark = 2,5 \text{ dm}^3 \quad \checkmark$
----------------------------------------------------------------------------------------------------------------------------------------------------------------------------------------------------------------------------------------------------------------------------------------------------------------------------------------------------	-----------------------------------------------------------------------------------------------------------------------------------------------------------------------------------------------------------------------------------------------------------------------------------------------------------------------------------------------------------------------------------------------------------------------------------

(5)

12.3.2

$$\text{ave rate/ gem. tempo} = \frac{\Delta n}{\Delta t} \quad \therefore 2,08 \times 10^{-4} = \frac{\Delta n}{(10 \times 60) - 0} \quad \checkmark \quad \therefore \Delta n = 0,125 \text{ mol}$$

$$n(\text{Mg}) = n(\text{H}_2) = 0,125 \text{ mol} \quad \checkmark \quad \text{and} \quad m(\text{Mg}) = nM = 0,125 \times 24 \quad \checkmark = 3 \text{ g} \quad \checkmark \quad (2,995 \text{ g}) \quad \checkmark$$

(5)

- 12.4
- Larger surface area/state of division. ✓
 - More particles (per volume) with correct orientation. ✓ (3)
 - More effective collisions per (unit) time./Frequency of effective collisions increases. ✓ **[17]**

QUESTION 13

- 13.1 Temperature ✓ (1)

- 13.2 Change in concentration of products/reactants per (unit) time. ✓✓ (2)

- 13.3 14 min ✓✓ (2)

- 13.4.1 Graph **B** ✓
(Experiment **3**) has the highest (acid) concentration/more particles/higher number of moles. ✓ (2)

- 13.4.2 Graph **C** ✓
(Experiment 5) is at highest temperature/more particles with sufficient kinetic energy. ✓ (2)

- 13.5.1 Speeds up the reaction./Increases the reaction rate. ✓ (1)

- 13.5.2 Equal to ✓ (1)

13.6

$$n(\text{Zn}) = \frac{m}{M} = \frac{1,5}{65} = 0,023 \text{ mol}$$

$$\text{rate} = -\frac{\Delta n}{\Delta t} = -\frac{(0 - 0,023)}{14 - 0} = 1,65 \times 10^{-3} \text{ (mol} \cdot \text{min}^{-1}) \quad \checkmark$$

[15]

CHEMICAL EQUILIBRIUM

QUESTION 1

- 1.1 The stage in a chemical reaction when the rate of forward reaction equals the rate of reverse reaction. ✓✓
OR The stage in a chemical reaction when the concentrations of reactants and products remain constant. (2)

1.2

OPTION 1

$$K_c = \frac{[\text{N}_2\text{O}_4]}{[\text{NO}_2]^2} \checkmark \therefore 171 \checkmark = \frac{[\text{N}_2\text{O}_4]}{(0,2)^2} \checkmark \therefore [\text{N}_2\text{O}_4] = 171 \times (0,2)^2 = 6,84 \text{ mol}\cdot\text{dm}^{-3}$$

	NO ₂	N ₂ O ₄	
Initial quantity (mol)	1,11 ✓	0	
Change (mol)	subtract ✓ 1,094	0,55 ✓	ratio ✓
Quantity at equilibrium (mol)/	0,016	0,55	
Equilibrium concentration (mol·dm ⁻³)	0,2	6,84	x 0,08 ✓

OPTION 2

$$K_c = \frac{[\text{N}_2\text{O}_4]}{[\text{NO}_2]^2} \checkmark \therefore 171 \checkmark = \frac{[\text{N}_2\text{O}_4]}{(0,2)^2} \checkmark \therefore [\text{N}_2\text{O}_4] = 171 \times (0,2)^2 = 6,84 \text{ mol}\cdot\text{dm}^{-3}$$

Equilibrium moles:

$$\left. \begin{aligned} n(\text{N}_2\text{O}_4) &= (6,84)(0,080) = 0,55 \text{ mol} \\ n(\text{NO}_2) &= (0,2)(0,080) = 0,016 \text{ mol} \end{aligned} \right\} \checkmark \times 0,08 \text{ dm}^3$$

$n(\text{N}_2\text{O}_4 \text{ formed}) = 0,55 - 0 = 0,55 \text{ mol} \checkmark$

Ratio: $n(\text{NO}_2 \text{ reacted}) = 2n(\text{N}_2\text{O}_4 \text{ formed}) = 2(0,55) = 1,094 \text{ mol} \checkmark$

Initial $n(\text{NO}_2) = 0,016 + 1,094 \checkmark = 1,11 \text{ (mol)} \checkmark$ (8)

- 1.3.1 Concentration (of the gases) increases. / Molecules become more condensed or move closer to each other. ✓ (1)
- 1.3.2
- Increase in pressure favours the reaction that leads to smaller number of moles of gas. ✓
 - Forward reaction is favoured. ✓
 - Number of moles/amount of N₂O₄ / colourless gas increases. ✓
- OR** Number of moles/amount of NO₂ / brown gas decreases. ✓ (3)
- 1.4.1 Darker ✓ (1)
- 1.4.2 Decreases ✓ (1)

[16]

QUESTION 2

- 2.1 A reaction is reversible when products can be converted back to reactants. ✓ (1)
- 2.2 No change ✓ (1)
- 2.3.1 Temperature decreases ✓ (1)
- 2.3.2
- Decrease in temperature decreases the rate of both forward and reverse reactions. ✓
 - Decrease in temperature favours the exothermic reaction. ✓
 - The rate of the reverse (exothermic) reaction is faster or the reverse reaction is favoured. ✓ (3)

2.4

OPTION 1/OPSIE 1

At equilibrium/by ewewig: $[\text{H}_2] = [\text{I}_2] \checkmark$

$$K_c = \frac{[\text{H}_2][\text{I}_2]}{[\text{HI}]^2} \checkmark$$

$$\therefore 0,02 \checkmark = \frac{(x)(x)}{\left(\frac{0,04}{2}\right)^2} \checkmark \quad \begin{array}{l} \text{Divide by } 2 \text{ dm}^3 \checkmark \\ \text{Deel deur } 2 \text{ dm}^3 \end{array}$$

$$\therefore x = [\text{H}_2] = 2,83 \times 10^{-3} \text{ mol}\cdot\text{dm}^{-3} \checkmark \quad (0,0028 \text{ mol}\cdot\text{dm}^{-3})$$

OPTION 2/OPSIE 2

	HI	H ₂	I ₂	
Initial quantity (mol) <i>Aanvangshoeveelheid (mol)</i>	x	0	0	
Change (mol) <i>Verandering (mol)</i>	x - 0,04	$\frac{x - 0,04}{2}$	$\frac{x - 0,04}{2}$	ratio ✓ <i>verhouding</i>
Quantity at equilibrium (mol)/ <i>Hoeveelheid by ewewig (mol)</i>	0,04	$\frac{x - 0,04}{2}$	$\frac{x - 0,04}{2}$	
Equilibrium concentration (mol·dm ⁻³) <i>Ewewigskonsentrasie (mol·dm⁻³)</i>	0,02	$\frac{x - 0,04}{4}$	$\frac{x - 0,04}{4}$	Divide by 2 dm ³ ✓ <i>Deel deur 2 dm³</i>

$$K_c = \frac{[H_2][I_2]}{[HI]^2} \checkmark$$

$$\therefore 0,02 \checkmark = \frac{\left(\frac{x - 0,04}{4}\right)\left(\frac{x - 0,04}{4}\right)}{(0,02)^2} \checkmark$$

$$\therefore x = 0,05$$

$$[H_2] = \frac{x - 0,04}{2}$$

$$= \frac{0,05 - 0,04}{2}$$

$$= 2,83 \times 10^{-3} \text{ mol}\cdot\text{dm}^{-3} \checkmark$$

No K_c expression, correct substitution/Geen K_c-uitdrukking, korrekte substitusie: Max./Maks. $\frac{5}{6}$

Wrong K_c expression/Verkeerde K_c-uitdrukking: Max./Maks. $\frac{2}{6}$

(6)

(6)

2.5 $K_c = \frac{1}{0,02} = 50 \checkmark$

(1)

2.6 Increases ✓

(1)

[14]**QUESTION 3**

3.1 When the equilibrium (in a closed system) is disturbed, the system will re-instate a new equilibrium ✓ by favouring the reaction that will cancel the disturbance. ✓

(2)

3.2.1 Remains the same ✓

(1)

3.2.2 Increases ✓

(1)

3.3

OPTION 1

$K_c = [NH_3][H_2S] \checkmark$
 $\therefore 1,2 \times 10^{-4} \checkmark = [NH_3][H_2S]$
 $\therefore [NH_3] = [H_2S] = 0,011 \text{ mol}\cdot\text{dm}^{-3}$
 $n(NH_3) = cV = (0,011)(5) \checkmark = 0,06 \text{ mol (0,06 mol)}$
 $n(NH_4HS) = n(NH_3) = 0,06 \text{ mol} \checkmark$
 $m(NH_4HS) = nM = (0,06)(51) \checkmark = 2,81 \text{ g} \checkmark$

OPTION 2

	NH ₄ HS	NH ₃	H ₂ S
Initial quantity (mol)		0	0
Change (mol)	x	x	x
Quantity at equilibrium (mol)	-	x	x
Equilibrium concentration (mol·dm ⁻³)	-	$\frac{x}{5}$	$\frac{x}{5}$

Divide by 5 ✓

$K_c = [NH_3][H_2S] \checkmark$
 $\therefore 1,2 \times 10^{-4} \checkmark = \left(\frac{x}{5}\right)\left(\frac{x}{5}\right) \therefore x = 0,0547 \text{ mol}$
 $m(NH_4HS) = nM = (0,0547) \checkmark (51) \checkmark = 2,79 \text{ g} \checkmark$

(6)

3.4 Decreases ✓

- Increase in pressure favours the reaction that leads to the smaller number of moles of gas. ✓✓
- The reverse reaction is favoured. ✓

(3)

[13]

QUESTION 4

4.1 Equal to ✓ ✓ (1)

4.2
$$K_c = \frac{[X_3]^2}{[X_2]^3} = \frac{(0,226)^2}{(0,06)^3} = 236,46$$
 ✓ ✓ (4)

4.3.1 Increases ✓

- 4.3.2
- The increase in $[X_3]$ is opposed. / Change is opposed. ✓
 - The reverse reaction is favoured. / X_3 is used. / $[X_3]$ decreases. ✓
- (2)

4.4 Higher than ✓ (1)

4.5 Exothermic ✓

- The concentration of the product / $X_3(g)$ is lower. / The concentration of the reactant / $X_2(g)$ is higher. ✓
- The increase in temperature favoured the reverse reaction. ✓
- According to Le Chatelier's principle an increase in temperature favours the endothermic reaction. ✓

OR

- $[X_3]$ decreases and $[X_2]$ increases. ✓
 - K_c decreases if temperature increases. ✓
 - Decrease in temperature favoured the forward reaction. ✓
- (4)

4.6

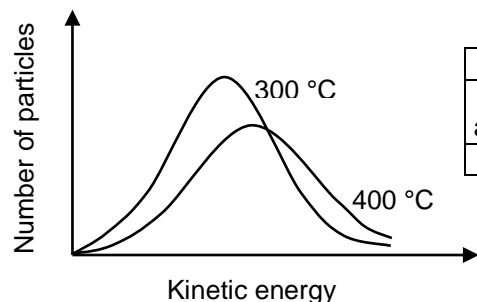

Marking criteria	
Peak of curve at 400 °C lower than at 300 °C and shifted to the right.	✓
Curve at 400 °C has larger area at the higher E_k .	✓

(2)
[15]**QUESTION 5**

5.1

OPTION 1

$$c = \frac{m}{MV} = \frac{2,2}{44 \times 5} = 0,01 \text{ mol} \cdot \text{dm}^{-3}$$

OPTION 2

$$n = \frac{m}{M} = \frac{2,2}{44} = 0,05 \text{ mol}$$

$$c = \frac{n}{V} = \frac{0,05}{5} = 0,01 \text{ mol} \cdot \text{dm}^{-3}$$

(4)

5.2 For equilibrium, a forward and a reverse reaction are needed. ✓

OR Without CaO(s), the reverse reaction is not possible. (1)5.3 CO₂ is a gas and will escape if the container is not sealed. ✓ (1)

5.4

OPTION 1

$$K_c = [\text{CO}_2] \checkmark$$

$$= 0,0108$$

$$\therefore [\text{CO}_2] = 0,0108 \text{ (mol} \cdot \text{dm}^{-3}) \checkmark$$

$$n(\text{CO}_2 \text{ at equilibrium/by ewewig}) = cV$$

$$= (0,0108)(5) \checkmark$$

$$= 0,054 \text{ mol}$$

$$n(\text{CO}_2 \text{ formed/gevorm}) = n(\text{CO}_2 \text{ at equilibrium/by ewewig})$$

$$n(\text{CO}_2 \text{ initially/begin})$$

$$= 0,054 - 0,05 \checkmark$$

$$= 0,004 \text{ mol}$$

$$n(\text{CaCO}_3) = n(\text{CO}_2 \text{ formed}) = 0,004 \text{ mol} \checkmark$$

$$m(\text{CaCO}_3) = nM$$

$$= (0,004)(100) \checkmark$$

$$= 0,4 \text{ g} \checkmark$$

OPTION 2

$$K_c = [\text{CO}_2] \checkmark$$

$$= 0,0108 \checkmark$$

$$\therefore [\text{CO}_2] = 0,0108 \text{ (mol}\cdot\text{dm}^{-3}\text{)}$$

	CaCO ₃	CaO	CO ₂
Initial quantity (mol) <i>Aanvangshoeveelheid (mol)</i>	0	0	0,05
Change (mol) <i>Verandering (mol)</i>	0,004	x	0,004 \checkmark
Quantity at equilibrium (mol) <i>Hoeveelheid by ewewig (mol)</i>			0,054 \checkmark
Equilibrium concentration (mol·dm ⁻³) <i>Ewewigskonsentrasie (mol·dm⁻³)</i>			0,0108

$$m(\text{CaCO}) = nM$$

$$= (0,004)(100) \checkmark$$

$$= 0,4 \text{ g} \checkmark$$

(7)

5.5.1 Remains the same \checkmark

(1)

5.5.2 Decreases \checkmark

(1)

5.6 Endothermic \checkmark

- K_c decreases with decrease in temperature. \checkmark
- Therefore the product of the concentration of products decreases./The reverse reaction is favoured. \checkmark
- A decrease in temperature favours the exothermic reaction. \checkmark

(4)

[19]**QUESTION 6**6.1 Reversible reaction \checkmark

(1)

6.2 Endothermic \checkmark ΔH is positive. / $\Delta H > 0 \checkmark$

(2)

6.3 Larger than \checkmark $K_c > 1 \checkmark$

(2)

6.4

OPTION 1

$$n = \frac{m}{M} = \frac{168}{28} \checkmark = 6 \text{ mol}$$

	CO ₂	CO
Initial quantity (mol)	x	0
Change (mol)	3	6 \checkmark
Quantity at equilibrium (mol)	x - 3 \checkmark	6
Equilibrium concentration (mol·dm ⁻³)	$\frac{x-3}{2}$	3

ratio \checkmark Divide by 2 \checkmark

$$K_c = \frac{[\text{CO}]^2}{[\text{CO}_2]} \checkmark \therefore 14 \checkmark = \frac{(3)^2}{\frac{x-3}{2}} \checkmark \therefore x = 4,29 \text{ mol} \checkmark$$

OPTION 2

$$n = \frac{m}{M} = \frac{168}{28} \checkmark = 6 \text{ mol} \text{ and } c = \frac{n}{V} = \frac{6}{2} \checkmark = 3 \text{ mol}\cdot\text{dm}^{-3}$$

	CO ₂	CO
Initial concentration (mol·dm ⁻³)	x	0
Change (mol·dm ⁻³)	1,5	3 \checkmark
Equilibrium concentration (mol·dm ⁻³)	x - 1,5 \checkmark	3

ratio \checkmark

$$K_c = \frac{[\text{CO}]^2}{[\text{CO}_2]} \checkmark \therefore 14 \checkmark = \frac{(3)^2}{x-1,5} \checkmark \therefore x = 2,14 \text{ mol}\cdot\text{dm}^{-3}$$

$$n(\text{CO}_2) = cV = (2,14)(2) = 4,29 \text{ mol} \checkmark$$

(9)

6.5.1 Remains the same \checkmark

(1)

6.5.2 Decreases \checkmark

(1)

6.5.3 Increases \checkmark

(1)

[17]

QUESTION 7

7.1 The stage in a chemical reaction when the rate of forward reaction equals the rate of reverse reaction. ✓✓

OR The stage in a chemical reaction when the concentrations / quantities of reactants and products remain constant. (2)

7.2.1 Remains the same ✓ (1)

7.2.2 Decreases ✓

- When the temperature is increased the reaction that will oppose this increase / decrease the temperature will be favoured. ✓ **OR** The forward reaction is exothermic.
- An increase in temperature favours the endothermic reaction. ✓
- The reverse reaction is favoured. ✓ (4)

7.3

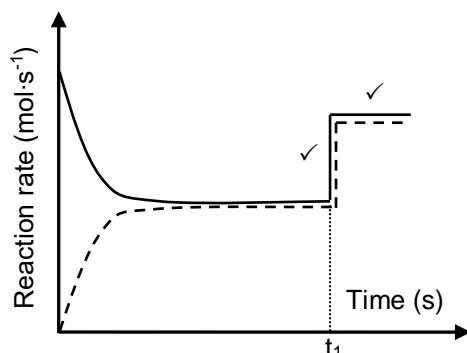
**Marking criteria**

- Vertical parallel lines show a sudden increase in rate of both forward and reverse reactions. ✓
- Horizontal parallel lines showing a constant higher rate for both forward and reverse catalysed reactions after time t_1 . ✓

(2)

7.4

OPTION 1

$$n(\text{PbS}) = \frac{m}{M} = \frac{2,39}{239} \neq 0,01 \text{ mol}$$

$$n(\text{H}_2\text{S})_{\text{equilibrium}} = n(\text{PbS}) \checkmark = 0,01 \text{ mol}$$

	H ₂	H ₂ S
Initial quantity (mol)	0,16	0
Change (mol)	0,01	0,01 ✓
Quantity at equilibrium (mol)	0,15 ✓	0,01
Equilibrium concentration (mol·dm ⁻³)	0,075	0,005

ratio ✓

divide by 2 ✓

$$K_c = \frac{[\text{H}_2\text{S}]}{[\text{H}_2]} \checkmark = \frac{0,005}{0,075} \checkmark = 0,067 \approx 0,07 \checkmark$$

OPTION 2

$$n(\text{PbS}) = \frac{m}{M} = \frac{2,39}{239} \neq 0,01 \text{ mol}$$

$$n(\text{H}_2\text{S})_{\text{reacted}} = n(\text{PbS}) \checkmark = 0,01 \text{ mol} = n(\text{H}_2\text{S})_{\text{equilibrium}}$$

$$n(\text{H}_2\text{S})_{\text{formed}} = n(\text{H}_2\text{S})_{\text{equilibrium}} - n(\text{H}_2\text{S})_{\text{initial}} = 0,01 - 0 \checkmark = 0,01 \text{ mol}$$

$$n(\text{H}_2)_{\text{reacted}} = n(\text{H}_2\text{S})_{\text{formed}} \checkmark = 0,01 \text{ mol}$$

$$n(\text{H}_2)_{\text{equilibrium}} = n(\text{H}_2)_{\text{initial}} - n(\text{H}_2)_{\text{reacted}} = 0,16 - 0,01 \checkmark = 0,15 \text{ mol}$$

$$c(\text{H}_2) = \frac{n}{V} = \frac{0,15}{2} = 0,075 \text{ mol}\cdot\text{dm}^{-3}$$

✓Divide by 2

$$c(\text{H}_2\text{S}) = \frac{n}{V} = \frac{0,01}{2} = 0,005 \text{ mol}\cdot\text{dm}^{-3}$$

$$K_c = \frac{[\text{H}_2\text{S}]}{[\text{H}_2]} \checkmark = \frac{0,005}{0,075} \checkmark = 0,067 \checkmark$$

(9)

[18]**QUESTION 8**

8.1.1 Products can be converted back to reactants. ✓

OR Both forward and reverse reactions can take place. (1)

8.1.2 Endothermic ✓ (1)

- 8.1.3
- K_c increases with increase in temperature. ✓
 - Forward reaction is favoured./Concentration of products increases./ Concentration of reactants decreases. ✓
 - Increase in temperature favours an endothermic reaction. ✓
- 8.1.4 Increases ✓
- 8.1.5 Remains the same ✓

8.2.1

OPTION 1

	Cl_2	Ti
Initial quantity (mol)	6 ✓	7
Change (mol)	2 ✓	1
Quantity at equilibrium (mol)	4	6 ✓
Equilibrium concentration (mol·dm ⁻³)	2	

Use mole ratio ✓

Divide by 2 ✓

$$K_c = \frac{1}{[Cl_2]^2} \checkmark = \frac{1}{(2)^2} \checkmark = 0,25 \checkmark$$

OPTION 2

$$n(Ti)_{\text{reacted}} = \frac{m}{M} = \frac{48}{48} \checkmark = 1 \text{ mol} \quad \text{and} \quad n(Cl_2)_{\text{reacted}} = 2n(Ti) = 2(1) \checkmark = 2 \text{ mol}$$

$$n(Cl_2)_{\text{initial}} = \frac{m}{M} = \frac{426}{71} \checkmark = 6 \text{ mol}$$

$$n(Cl_2)_{\text{equilibrium}} = 6 - 2 \checkmark = 4 \text{ mol}$$

$$c = \frac{n}{V} = \frac{4}{2} \checkmark = 2 \text{ mol} \cdot \text{dm}^{-3}$$

$$K_c = \frac{1}{[Cl_2]^2} \checkmark = \frac{1}{(2)^2} \checkmark = 0,25 \checkmark$$

8.2.2 Remains the same ✓

(8)

(1)

[16]

QUESTION 9

- 9.1 Amount / number of moles / volume of (gas) reactants equals amount/number of moles/volume of (gas) products. ✓
- OR** A change in pressure will change the concentration of the reactants and products equally. (1)

9.2

OPTION 1

$$K_c = \frac{[HI]^2}{[H_2][I_2]} \checkmark \therefore 55,3 \checkmark = \frac{[HI]^2}{(0,014)(0,0085)} \checkmark \therefore [HI] = 0,08112 \text{ mol} \cdot \text{dm}^{-3}$$

	H_2	I_2	HI
Initial mass (g)		$(0,09812)(254) \checkmark = 24,92 \text{ g} \checkmark$	
Initial quantity (mol)	0,1091	0,09812	0
Change (mol)	0,08112	✓0,08112	0,1622 ✓
Quantity at equilibrium (mol)	0,028	0,017	0,1622
Equilibrium concentration (mol·dm ⁻³)	0,014	0,0085	0,08112

Using ratio ✓

Divide by 2 ✓

OPTION 2

$$K_c = \frac{[HI]^2}{[H_2][I_2]} \checkmark \therefore 55,3 \checkmark = \frac{x^2}{(0,014)(0,0085)} \checkmark \therefore x = 0,08112 \text{ mol} \cdot \text{dm}^{-3}$$

	H_2	I_2	HI
Initial mass (g)			
Initial quantity (mol)	$x + 0,028$	$x + 0,017$	0
Change (mol)	x	x	2x ✓
Quantity at equilibrium (mol)	0,028	✓0,017	2x
Equilibrium concentration (mol·dm ⁻³)	0,014	0,0085	x

Using ratio ✓

Divide by 2 ✓

Initial quantity I_2 (mol) = $0,08112 + 0,017 = 0,09812 \text{ mol}$
 $m(I_2) = nM = (0,09812)(254) \checkmark = 24,92 \text{ g} \checkmark$

(9)

- 9.3 Chemical/dynamic equilibrium ✓ (1)
- 9.4 Addition of a catalyst. ✓ AND Increase in pressure. ✓ (2)
- 9.5.1 Endothermic ✓
 • The rate of the forward reaction decreases more. / The rate of the reverse reaction decreases less. ✓
 • A decrease in temperature favours the exothermic reaction. ✓ (3)
- 9.5.2 Decreases ✓ (1)
- 9.6 Reactants / H₂ / I₂ removed (1)
- [18]

QUESTION 10

- 10.1 The stage in a chemical reaction when the rate of forward reaction equals the rate of reverse reaction. ✓✓
 OR The stage in a chemical reaction when the concentrations/amount of reactants and products remain constant. ✓✓ (2)

10.2

OPTION 1

$$n = \frac{m}{M} = \frac{1,12}{28} = 0,04 \text{ mol}$$

	COBr ₂	CO	Br ₂
Initial quantity (mol)		0	0
Change (mol)	0,04	0,04	0,04
Quantity at equilibrium (mol)		0,04	0,04 ✓
Equilibrium concentration (mol·dm ⁻³)		0,02	0,02

$$K_c = \frac{[\text{CO}][\text{Br}_2]}{[\text{COBr}_2]} \checkmark 0,19 \checkmark = \frac{(0,02)^2}{[\text{COBr}_2]} \checkmark c(\text{COBr}_2)_{\text{eq}} = 2,11 \times 10^{-3} \text{ mol}\cdot\text{dm}^{-3} \checkmark$$

(7)

OPTION 2

$$n = \frac{m}{M} = \frac{1,12}{28} = 0,04 \text{ mol}$$

	COBr ₂	CO	Br ₂
Initial quantity (mol)	x	0	0
Change (mol)	0,04	0,04	0,04
Quantity at equilibrium (mol)	x - 0,04	0,04	0,04 ✓
Equilibrium concentration	$\frac{x - 0,04}{2}$	0,02	0,02 Divide by 2 ✓

$$K_c = \frac{[\text{CO}][\text{Br}_2]}{[\text{COBr}_2]} \checkmark \therefore 0,19 \checkmark = \frac{(0,02)^2}{\frac{x - 0,04}{2}} \checkmark \therefore x = 0,0442 \text{ mol}$$

$$\therefore c(\text{COBr}_2)_{\text{eq}} = 2,11 \times 10^{-3} \text{ mol}\cdot\text{dm}^{-3} \checkmark$$

10.3

OPTION 1

$$n(\text{COBr}_2)_{\text{eq}} = cV = 2,11 \times 10^{-3} \times 2 \checkmark$$

$$= 4,22 \times 10^{-3} \text{ mol}$$

$$n(\text{COBr}_2)_{\text{initial}} = 0,04 + 4,22 \times 10^{-3} \checkmark$$

$$= 0,044 \text{ mol}$$

$$\% \text{ decomposed} = \frac{0,04}{0,044} \checkmark \times 100 = 90,46\% \checkmark \quad (90,3 - 90,9\%)$$

OPTION 2: From Q10.2 Option 2

$$n(\text{COBr}_2)_{\text{initial}} = x = 0,0442 \text{ mol} \checkmark \checkmark$$

$$n(\text{COBr}_2)_{\text{react}} = 0,04 \text{ mol}$$

(4)

- 10.4 $K_c < 0,19$ ✓ (1)
- 10.5 Decreases ✓
 A decreases in pressure favours the reaction that produces the larger number of moles/volume (units) of gas. ✓
 The forward reaction will be favoured. ✓ (3)
- [17]

QUESTION 11

- 11.1.1 When the equilibrium in a closed system is disturbed, the system will re-instate a new equilibrium by favouring the reaction that will oppose the disturbance. ✓✓ (2)

- 11.1.2
- Percentage yield increases with an increase in temperature. ✓
 - Forward reaction is favoured. ✓
 - Increase in temperature favours an endothermic reaction. ✓.
- (3)
- 11.1.3 When the pressure increases, the reaction that leads to a decrease in the number of moles will be favoured. ✓✓
- (2)
- 11.1.4 | ✓✓
- (2)

11.2

OPTION 1

	HCl	O ₂	Cl ₂	H ₂ O	
Initial quantity (mol)	0,2	0,11	0	0	
Change (mol)	0,15 ✓	0,0375	0,075	0,075	ratio ✓
Quantity at equilibrium (mol)	$\frac{1,825}{36,5} = 0,05$ ✓	0,0725	0,075	0,075	✓
Equilibrium concentration (mol·dm ⁻³)	0,25	0,3625	0,375	0,375	Divide by 0,2 ✓

$$K_c = \frac{[\text{Cl}_2]^2 [\text{H}_2\text{O}]^2}{[\text{HCl}]^4 [\text{O}_2]} = \frac{(0,375)^2 (0,375)^2}{(0,25)^4 (0,3625)} = 13,97$$

OPTION 2

$$n(\text{HCl})_{\text{equilibrium}} = \frac{m}{M} = \frac{1,825}{36,5} = 0,05 \text{ mol}$$

$$n(\text{HCl})_{\text{reacted}} = 0,2 - 0,05 = 0,15 \text{ mol}$$

$$\left. \begin{aligned} n(\text{O}_2)_{\text{reacted}} &= \frac{1}{4}n(\text{HCl})_{\text{reacted}} = \frac{1}{4} \times 0,15 = 0,0375 \text{ mol} \\ n(\text{Cl}_2)_{\text{formed}} &= \frac{1}{2}n(\text{HCl})_{\text{reacted}} = \frac{1}{2} \times 0,15 = 0,075 \text{ mol} \\ n(\text{H}_2\text{O})_{\text{formed}} &= \frac{1}{2}n(\text{HCl})_{\text{reacted}} = \frac{1}{2} \times 0,15 = 0,075 \text{ mol} \end{aligned} \right\} \text{Using ratio } \checkmark$$

$$\left. \begin{aligned} n(\text{O}_2)_{\text{equilibrium}} &= 0,11 - 0,0375 = 0,0725 \text{ mol} \\ n(\text{Cl}_2)_{\text{equilibrium}} &= n(\text{H}_2\text{O})_{\text{equilibrium}} = 0,075 \text{ mol} \end{aligned} \right\} \checkmark$$

$$\left. \begin{aligned} c(\text{O}_2)_{\text{equilibrium}} &= \frac{n}{V} = \frac{0,0375}{0,2} = 0,3625 \text{ mol}\cdot\text{dm}^{-3} \\ c(\text{Cl}_2)_{\text{equilibrium}} &= c(\text{H}_2\text{O})_{\text{equilibrium}} = \frac{n}{V} = \frac{0,075}{0,2} = 0,375 \text{ mol}\cdot\text{dm}^{-3} \end{aligned} \right\} \text{Divide by } 0,2 \checkmark$$

$$K_c = \frac{[\text{Cl}_2]^2 [\text{H}_2\text{O}]^2}{[\text{HCl}]^4 [\text{O}_2]} = \frac{(0,375)^2 (0,375)^2}{(0,25)^4 (0,3625)} = 13,97$$
(9)
[18]**QUESTION 12**

- 12.1 The stage in a chemical reaction when the rate of forward reaction equals the rate of reverse reaction. ✓✓
OR The stage in a chemical reaction when the concentrations of reactants and products remain constant. ✓✓
- (2)
- 12.2.1 2 ✓ (1)
- 12.2.2 1 ✓ (1)
- 12.2.3 3 ✓ (1)

12.3

OPTION 1

$$\left. \begin{aligned} [\text{A}] &= \frac{8}{3} = 2,67 \text{ mol}\cdot\text{dm}^{-3} \\ [\text{B}] &= \frac{4}{3} = 1,33 \text{ mol}\cdot\text{dm}^{-3} \\ [\text{C}] &= \frac{12}{3} = 4 \text{ mol}\cdot\text{dm}^{-3} \end{aligned} \right\} \text{Divide by } 3 \text{ dm}^3 \checkmark$$

$$K_c = \frac{[\text{C}]^3}{[\text{A}]^2 [\text{B}]} = \frac{(4)^3}{(2,67)^2 (1,33)} = 6,75$$

OPTION 2			
	A	B	C
Initial quantity (mol)	16	8	0
Change (mol)	8	4	12
Quantity at equilibrium (mol)	8 ✓	4 ✓	12 ✓
Equilibrium concentration (mol·dm ⁻³)	$\frac{8}{3}$	$\frac{4}{3}$	$\frac{12}{3}$

Divide by 3 dm³ ✓

$$K_c = \frac{[C]^3}{[A]^2[B]} \checkmark = \frac{(4)^3}{(2,67)^2(1,33)} \checkmark = 6,75 \checkmark$$

(7)

12.4 Endothermic ✓

- (An increase in temperature) favours the reverse reaction. ✓
- An increase in temperature favours an endothermic reaction. ✓

(3)

[15]**QUESTION 13**13.1 When the equilibrium in a closed system is disturbed, the system will re-instate a (new) equilibrium ✓ by favouring the reaction that will cancel/oppose the disturbance. ✓

(2)

13.2 Endothermic ✓

- Decrease in temperature favours the exothermic reaction. ✓
- The reverse reaction is favoured./*Die terugwaartse reaksie word bevoordeel.* ✓
OR Number of moles/amount/concentration of N₂O₄/colourless gas increases.
OR Number of moles/amount of NO₂/brown gas decreases.

(3)

13.3.1 Increases ✓

(1)

13.3.2 Remains the same ✓

(1)

13.3.3 Increases ✓

(1)

13.4

OPTION 1		
	N ₂ O ₄	NO ₂
Initial amount (moles)	x	0
Change in amount (moles)	0,2x ✓	0,4x
Equilibrium amount (moles)	0,8x	0,4x
Equilibrium concentration (mol·dm ⁻³)	0,4x	0,2x

ratio ✓
Divide by 2 dm³ ✓

$$K_c = \frac{[NO_2]^2}{[N_2O_4]} \checkmark \therefore 0,16 = \frac{(0,2x)^2}{(0,4x)} \checkmark \therefore x = 1,6 \text{ mol } \checkmark$$

OPTION 2

$$\Delta n(N_2O_4) = \frac{20}{100}x \checkmark = 0,2x \text{ AND } \Delta n(NO_2) = 2\Delta n(N_2O_4) = 0,4x \checkmark$$

$$n(N_2O_4)_{eq} = x - 0,2x = 0,8x \text{ AND } n(NO_2)_{eq} = 0 + 0,4x \checkmark$$

$$\left. \begin{aligned} c(N_2O_4)_{eq} &= \frac{0,8x}{2} = 0,4x \\ c(NO_2)_{eq} &= \frac{0,4x}{2} = 0,2x \end{aligned} \right\} \checkmark$$

$$K_c = \frac{[NO_2]^2}{[N_2O_4]} \checkmark \therefore 0,16 = \frac{(0,2x)^2}{(0,4x)} \checkmark \therefore x = 1,6 \text{ mol } \checkmark$$

(8)

[16]**ACIDS AND BASES****QUESTION 1**

1.1.1 Ionises / dissociates completely in water. ✓

(1)

1.1.2 NO₃⁻ / Nitrate ion ✓

(1)

1.1.3 pH = -log[H₃O⁺] / -log[H⁺] ✓ = -log(0,3) ✓ = 0,52 ✓

(3)

1.2.1

$$c = \frac{n}{V} \checkmark \therefore 2 = \frac{n}{0,1} \checkmark \therefore n(HCl) = 0,2 \text{ mol } \checkmark$$

(3)

1.2.2 Burette ✓

(1)

1.2.3 B ✓ Titration of strong acid and strong base. ✓✓ (3)

1.2.4 The number of moles of acid in the flask remains constant. ✓ (1)

1.2.5 $c = \frac{n}{V}$ ✓ $\therefore 0,2 = \frac{n}{0,021}$ ✓ $\therefore n = 4,2 \times 10^{-3} \text{ mol}$ ✓ $n(\text{HCl})_{\text{excess}} = n(\text{NaOH}) = 4,2 \times 10^{-3} \text{ mol}$ (3)

1.2.6	OPTION 1	OPTION 2
	$n(\text{HCl reacted}):$ $0,2 - 4,2 \times 10^{-3}$ ✓ = 0,196 mol	$n(\text{HCl reacted}) = \frac{0,2 - 4,2 \times 10^{-3}}{1}$ ✓ = 0,196 mol
	$n(\text{MgO reacted}):$ $\frac{1}{2}n(\text{HCl}) = \frac{1}{2}(0,196) = 9,8 \times 10^{-2} \text{ mol}$ ✓	$n(\text{HCl reacted}) = \frac{m}{M}$ $\therefore 0,196 = \frac{m}{36,5}$
	$n(\text{MgO reacted}) = \frac{m}{M}$ $\therefore 0,098 = \frac{m}{40}$ ✓ $\therefore m = 3,92 \text{ g}$	$\therefore m(\text{HCl reacted}) = 7,154 \text{ g}$
	$\% \text{ purity} = \frac{3,92}{4,5 \times 100}$ ✓ = 87,11% ✓	40 g MgO ✓ 73 g HCl ✓ x g MgO 7,154 g $\therefore x = 3,92 \text{ g}$
		$\% \text{ purity} = \frac{3,92}{4,5 \times 100}$ ✓ = 87,11% ✓

(5)
[21]

QUESTION 2

2.1.1 An acid is a proton (H^+ ion) donor. ✓ (1)

2.1.2 It ionises to form 2 protons for each H_2SO_4 molecule. / It ionises to form 2 moles of H^+ ions. ✓
OR It donates 2 H^+ ions per H_2SO_4 molecule. (1)

2.2.1 Amphiprotic substance / Ampholyte ✓ (1)

2.2.2 H_2CO_3 ✓ (1)

2.3.1 $n(\text{NaHCO}_3) = \frac{m}{M}$ ✓
 $= \frac{27}{84}$ ✓
 $= 0,32 \text{ mol}$ (0,0321485 mol)

$n(\text{H}_2\text{SO}_4) = \frac{1}{2}n(\text{NaHCO}_3) = \frac{1}{2}(0,32)$ ✓ = 0,16 mol (0,01607142 mol)

$c = \frac{n}{V}$ ✓
 $6 = \frac{0,16}{V}$ ✓

$\therefore V = 0,03 \text{ dm}^3$ ✓ (30 $\text{cm}^3/0,027 \text{ dm}^3/27 \text{ cm}^3$) (6)

2.3.2 $n_a(\text{initial/aanvanklik}) = n_a(\text{final/finaal})$
 $c_a v_a(\text{initial/aanvanklik}) = c_a v_a(\text{final/finaal})$
 $\therefore (6)v_a = (0,1)(1)$ ✓
 $\therefore v_a = 0,02 \text{ dm}^3$ ✓ (20 $\text{cm}^3/0,0167 \text{ dm}^3/16,7 \text{ cm}^3$) (2)

2.3.3 Shows end point of titration. / Shows when neutralisation occurs. ✓ (1)

2.3.4 $n_a(\text{initial/aanvanklik}) = c_a v_a$
 $= (0,1)(25 \times 10^{-3})$ ✓
 $= 2,5 \times 10^{-3} \text{ mol}$

$n_b(\text{reacted/gereageer}) = c_b v_b$
 $= (0,1)(30 \times 10^{-3})$ ✓
 $= 3 \times 10^{-3} \text{ mol}$

$\frac{n_a}{n_b} = \frac{1}{2}$
 $\therefore n_a(\text{neutralised/geneutraliseer}) = \frac{1}{2}n_b = \frac{1}{2}(3 \times 10^{-3})$ ✓ = $1,5 \times 10^{-3} \text{ mol}$

$n_a(\text{left/oorgebly}) = n_a(\text{initial/aanvanklik}) - n_a(\text{neutralised/geneutraliseer})$
 $= 2,5 \times 10^{-3} - 1,5 \times 10^{-3}$ ✓
 $= 1 \times 10^{-3} \text{ mol}$

$c_a = \frac{n}{V}$
 $= \frac{1 \times 10^{-3}}{(25 \times 10^{-3} + 30 \times 10^{-3})}$ ✓
 $= 0,018 \text{ mol} \cdot \text{dm}^{-3}$

$\text{pH} = -\log[\text{H}_3\text{O}^+]$ ✓
 $= -\log(2 \times 0,018)$ ✓
 $= 1,44$ ✓ (8)
[22]

QUESTION 3

3.1.1 Diprotic ✓ (1)

3.1.2 H_2O ✓ and $(\text{COO})_2^{2-}$ ✓ (2)3.1.3 $\text{H}(\text{COO})_2^- / \text{HC}_2\text{O}_4^-$ It acts as base (in reaction I) and as acid (in reaction II). ✓ (2)

3.2 Ionises / dissociates incompletely / partially. ✓ (1)

3.3	OPTION 1 $c = \frac{m}{MV}$ ✓ $\therefore 0,2 = \frac{m}{0,25 \times 90}$ ✓ $\therefore m = 4,5 \text{ g}$ ✓	OPTION 2 $c = \frac{n}{V}$ ✓ $\therefore 0,2 = \frac{n}{0,25}$ ✓ $\therefore n = 0,05 \text{ mol}$ $n = \frac{m}{M}$ $\therefore 0,05 = \frac{m}{90}$ ✓ $\therefore m = 4,5 \text{ g}$ ✓
-----	---------------------------------------------------------------------------------------------------------------------------	-------------------------------------------------------------------------------------------------------------------------------------------------------------------------------------------------------

3.4.1	OPTION 1 $\frac{c_a V_a}{c_b V_b} = \frac{n_a}{n_b}$ ✓ $\frac{0,2 \times 25}{c_b \times 36} = \frac{1}{2}$ ✓ $\therefore c_b = 0,28 \text{ mol} \cdot \text{dm}^{-3}$ ✓	OPTION 2 $n((\text{COOH})_2) = cV$ ✓ $= (0,2)(0,025)$ ✓ $= 0,005 \text{ mol}$ $n(\text{NaOH}) = 2(0,005)$ ✓ $= 0,01 \text{ mol}$ • $c = \frac{n}{V} = \frac{0,01}{0,0036}$ ✓ $= 0,28 \text{ mol} \cdot \text{dm}^{-3}$ ✓
-------	--------------------------------------------------------------------------------------------------------------------------------------------------------------------------------------	---------------------------------------------------------------------------------------------------------------------------------------------------------------------------------------------------------------------------------------------

3.4.2 $(\text{COO})_2^{2-}(\text{aq}) + 2\text{H}_2\text{O}(\ell) \rightleftharpoons (\text{COOH})_2(\text{aq}) + 2\text{OH}^-(\text{aq})$ ✓ Bal. ✓ (3)**[18]****QUESTION 4**

4.1.1 Hydrolysis ✓ (1)

4.1.2 Acidic ✓ Forms H_3O^+ ions during hydrolysis. ✓ **OR** Salt of strong acid and weak base. (2)4.2.1 $n = cV$ ✓ $= (0,1)(0,1)$ ✓ $= 0,01 \text{ mol}$ ✓ (3)

4.2.2	$n(\text{HCl}) = c_a V_a = (0,11)(14,55 \times 10^{-3})$ ✓ $= 1,6 \times 10^{-3} \text{ mol}$ $n(\text{NaOH}) = n(\text{HCl}) = 1,6 \times 10^{-3} \text{ mol}$ ✓ $n(\text{NaOH excess}) \text{ in } 100 \text{ cm}^3 = 1,6 \times 10^{-3} \times 4$ ✓ $= 6,4 \times 10^{-3} \text{ mol}$ $n(\text{NaOH reacted}) = 0,01 - 6,4 \times 10^{-3}$ ✓ $= 3,6 \times 10^{-3} \text{ mol}$ $n(\text{NH}_4\text{Cl}) = n(\text{NaOH}) = 3,6 \times 10^{-3} \text{ mol}$ ✓ (0,003598 mol)		
	$m(\text{NH}_4\text{Cl}) = nM$ $= (3,6 \times 10^{-3})(53,5)$ ✓ $= 0,193 \text{ g}$ 92% : 0,193 g 100% : x $\therefore x = \frac{0,193 \times 100}{92}$ ✓ $= 0,21 \text{ g}$ ✓	$n(\text{NH}_4\text{Cl}) = 0,92 \frac{x}{53,5}$ ✓ $\therefore 3,6 \times 10^{-3} = 0,92 \frac{x}{53,5}$ ✓ $\therefore x = 0,21 \text{ g}$ ✓	$n(\text{NH}_4\text{Cl}) = \frac{m}{53,5}$ $\therefore 3,6 \times 10^{-3} = \frac{m}{53,5}$ ✓ $n(\text{NH}_4\text{Cl}) = 0,192 \text{ g}$ $m(\text{fertiliser}) = \frac{0,192 \times 100}{92}$ ✓ $= 0,21 \text{ g}$ ✓

(8)

4.3	OPTION 1 $[\text{OH}^-] = [\text{NaOH}] = 0,5 \text{ mol} \cdot \text{dm}^{-3}$ $K_w = [\text{H}_3\text{O}^+][\text{OH}^-]$ $1 \times 10^{-14} = [\text{H}_3\text{O}^+]0,5$ ✓ $\therefore [\text{H}_3\text{O}^+] = 2 \times 10^{-14} \text{ mol} \cdot \text{dm}^{-3}$ $\text{pH} = -\log[\text{H}^+]$ ✓ $= -\log(2 \times 10^{-14})$ ✓ $= 13,7$ ✓	OPTION 2 $\text{pOH} = -\log[\text{OH}^-]$ ✓ $= -\log(0,5)$ ✓ $= 0,301$ $\text{pH} + \text{pOH} = 14$ $\text{pH} = 14 - 0,301$ ✓ $= 13,7$ ✓ (13,699)
-----	--------------------------------------------------------------------------------------------------------------------------------------------------------------------------------------------------------------------------------------------------------------------------------------------------------------------------------------------------------------------------------	-------------------------------------------------------------------------------------------------------------------------------------------------------------------------------

(4)
[18]**QUESTION 5**

5.1 It is a proton donor. ✓✓ (2)

5.2.1 $\text{CO}_3^{2-}(\text{aq})$ ✓ (1)5.2.2 $\text{H}_2\text{CO}_3 + \text{H}_2\text{O} \rightleftharpoons \text{HCO}_3^-(\text{aq}) + \text{H}_3\text{O}^+(\text{aq})$ ✓ Bal. ✓ (3)

5.2.3

<p>OPTION/OPSIE 1</p> <p>$\text{pH} = -\log[\text{H}^+] \checkmark$ $3,4 = -\log[\text{H}^+] \checkmark$ $[\text{H}^+] = 10^{-3,4} / 3,98 \times 10^{-4} \text{ mol}\cdot\text{dm}^{-3}$</p> <p>$[\text{H}^+][\text{OH}^-] = 10^{-14} \checkmark$ $\therefore [\text{OH}^-] = \frac{1 \times 10^{-14}}{3,98 \times 10^{-4}} \checkmark$ $= 2,51 \times 10^{-11} \text{ mol}\cdot\text{dm}^{-3} \checkmark$</p>	<p>OPTION/OPSIE 2</p> <p>$\text{pH} + \text{pOH} = 14 \checkmark$ $3,4 + \text{pOH} = 14 \checkmark$ $\text{pOH} = 11,6$</p> <p>$\text{pOH} = -\log[\text{OH}^-] \checkmark$ $11,6 = -\log[\text{OH}^-] \checkmark$ $[\text{OH}^-] = 10^{-11,6} / 2,51 \times 10^{-11} \text{ mol}\cdot\text{dm}^{-3} \checkmark$</p>
-------------------------------------------------------------------------------------------------------------------------------------------------------------------------------------------------------------------------------------------------------------------------------------------------------------------------------------------------------------------------------------------------------------------------------------------------------------------------------------------------------------	--------------------------------------------------------------------------------------------------------------------------------------------------------------------------------------------------------------------------------------------------------------------------------------------------------------------------------------------------------------------------------------------------------------------

(5)

5.3.1

An acid that donates ONE proton / H^+ ion / H_3O^+ ion. \checkmark **OR** An acid of which ONE mol ionises to form ONE mol of protons / H^+ ions / H_3O^+ ions.

(1)

5.3.2

<p>OPTION/OPSIE 1</p> <p>$\frac{c_a \times V_a}{c_b \times V_b} = \frac{n_a}{n_b} \checkmark$ $\frac{c_a \times 25}{0,1 \times 27,5} = \frac{1}{1} \checkmark$ $c_a = 0,11 \text{ mol}\cdot\text{dm}^{-3} \checkmark$</p>	<p>OPTION/OPSIE 2</p> <p>$n(\text{NaOH}) = cV \checkmark$ $= 0,1 \times 0,0275 \checkmark$ $= 0,00275 \text{ mol}$</p> <p>$n(\text{acid X}) = n(\text{NaOH})$ $= 0,00275 \text{ mol} \checkmark$</p> <p>$c(\text{acid X}) = \frac{n}{V}$ $= \frac{2,75 \times 10^{-3}}{0,025} \checkmark$ $= 0,11 \text{ mol}\cdot\text{dm}^{-3} \checkmark$</p>
-----------------------------------------------------------------------------------------------------------------------------------------------------------------------------------------------------------------------------------------------------------------------------	--------------------------------------------------------------------------------------------------------------------------------------------------------------------------------------------------------------------------------------------------------------------------------------------------------------------------------------------------------------------------------------------------------------------------------------------------------------------------

(5)

5.3.3

Weak \checkmark The $[\text{H}^+]$ OR $[\text{H}_3\text{O}^+]$ is lower than the concentration of acid X. \checkmark Therefore the acid is incompletely ionised. \checkmark

(3)

[20]**QUESTION 6**

6.1.1

An acid is a proton/ H^+ donor. $\checkmark\checkmark$ **NOTE: NOT H_3O^+**

(2)

6.1.2

 $\text{H}_2\text{O} \checkmark$ and $\text{H}_2\text{CO}_3 \checkmark$

(2)

6.1.3

 $\text{H}_2\text{O} \checkmark$ **OR** HCO_3^-

(1)

6.2.1

$n(\text{HCl}) = cV \checkmark = (0,1)(0,5) \checkmark = 0,05 \text{ mol}$
 $n(\text{NaHCO}_3) = cV = (0,25)(0,8) \checkmark = 0,2 \text{ mol}$
 $n(\text{NaHCO}_3)_{\text{reacted}} = n(\text{HCl}) = 0,05 \text{ mol} \checkmark$
 $n(\text{NaHCO}_3)_{\text{excess}} = 0,2 - 0,05 \checkmark = 0,15 \text{ mol}$
 $n(\text{OH}^-) = n(\text{NaHCO}_3) \checkmark = 0,15 \text{ mol}$

$$c(\text{OH}^-) = \frac{n}{V} = \frac{0,15}{1,3} \checkmark = 0,12 \text{ mol}\cdot\text{dm}^{-3} \checkmark$$

(8)

6.2.2

<p>OPTION 1</p> <p>$K_w = [\text{H}_3\text{O}^+][\text{OH}^-] = 1 \times 10^{-14}$ $1 \times 10^{-14} = [\text{H}_3\text{O}^+](0,12) \checkmark$ $[\text{H}_3\text{O}^+] = 8,33 \times 10^{-14} \text{ mol}\cdot\text{dm}^{-3}$ $\text{pH} = -\log [\text{H}_3\text{O}^+] \checkmark = -\log(8,33 \times 10^{-14}) \checkmark$ $= 13,08 \checkmark$</p>	<p>OPTION 2</p> <p>$\text{pOH} = -\log[\text{OH}^-] \checkmark = -\log(0,12) \checkmark$ $= 0,92$</p> <p>$\text{pH} + \text{pOH} = 14$ $\text{pH} + 0,92 = 14 \checkmark$ $\text{pH} = 13,08 \checkmark$</p>
-------------------------------------------------------------------------------------------------------------------------------------------------------------------------------------------------------------------------------------------------------------------------------------------------------------------------------------------------------------------------------------------------------------------------------------------	-------------------------------------------------------------------------------------------------------------------------------------------------------------------------------------------------------------------------------------------------------------------------------------------

(4)

[17]**QUESTION 7**

7.1.1

Hydrolysis is the reaction of a salt with water. $\checkmark\checkmark$

(2)

7.1.2

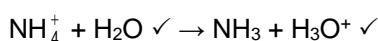
Smaller than 7 \checkmark 

(3)

7.2.1

<p>OPTION 1</p> <p>$n = \frac{m}{M} = \frac{7,35}{98} \checkmark = 0,08 \text{ mol} \checkmark$</p>	<p>OPTION 2</p> <p>$98 \text{ g} \checkmark : 1 \text{ mol}$ $7,35 : 0,08 \text{ mol} \checkmark$</p>	<p>OPTION 3</p> <p>$c = \frac{m}{MV} = \frac{7,35}{98 \times 0,5} = 0,15 \text{ mol}\cdot\text{dm}^{-3}$ $n = cV = 0,15 \times 0,5 = 0,08 \text{ mol} \checkmark$</p>
-----------------------------------------------------------------------------------------------------------------------	-----------------------------------------------------------------------------------------------------------------------------------------	---------------------------------------------------------------------------------------------------------------------------------------------------------------------------------------------------------

(2)

7.2.2

OPTION 1

$$\begin{aligned} \text{pH} &= -\log[\text{H}_3\text{O}^+] \checkmark \\ 1,3 \checkmark &= -\log[\text{H}_3\text{O}^+] \\ [\text{H}_3\text{O}^+] &= 0,05 \text{ mol}\cdot\text{dm}^{-3} \\ [\text{H}_2\text{SO}_4] &= \frac{1}{2}[\text{H}_3\text{O}^+] = \frac{1}{2} \times 0,05 \checkmark \\ &= 0,025 \text{ mol}\cdot\text{dm}^{-3} \\ n(\text{H}_2\text{SO}_4)_{\text{excess}} &= cV \checkmark = 0,025 \times 0,5 \checkmark \\ &= 0,0125 \text{ mol} \end{aligned}$$

Q7.2.1

$$\begin{aligned} n(\text{H}_2\text{SO}_4)_{\text{react}} &= 0,075 - 0,0125 \checkmark \\ &= 0,0625 \text{ mol} \end{aligned}$$

$$\begin{aligned} n(\text{NaOH}) &= 2n(\text{H}_2\text{SO}_4) = 2 \times 0,0625 \checkmark \\ &= 0,125 \text{ mol} \end{aligned}$$

OR

$$\begin{aligned} n(\text{NaOH}) &= \frac{m}{M} \checkmark & 1 \text{ mol} : 40 \text{ g} \checkmark \\ \therefore 0,125 &= \frac{m}{40} & 0,125 \text{ mol} : 5 \text{ g} \checkmark \\ \therefore m &= 5 \text{ g} \checkmark \end{aligned}$$

OPTION 2

$$\begin{aligned} [\text{H}_2\text{SO}_4]_{\text{in}} &= \frac{n}{V} \checkmark = \frac{0,075}{0,5} \checkmark \\ &= 0,15 \text{ mol}\cdot\text{dm}^{-3} \\ [\text{H}_3\text{O}^+]_{\text{initially}} &= 2[\text{H}_2\text{SO}_4] = 2 \times 0,15 \checkmark \\ &= 0,3 \text{ mol}\cdot\text{dm}^{-3} \end{aligned}$$

$$\begin{aligned} \text{pH} &= -\log[\text{H}_3\text{O}^+] \checkmark \therefore 1,3 \checkmark = -\log[\text{H}_3\text{O}^+] \\ [\text{H}_3\text{O}^+] &= 0,05 \text{ mol}\cdot\text{dm}^{-3} \\ [\text{H}_3\text{O}^+]_{\text{react}} &= 0,3 - 0,05 \checkmark = 0,25 \text{ mol}\cdot\text{dm}^{-3} \\ [\text{H}_2\text{SO}_4]_{\text{react}} &= \frac{1}{2}[\text{H}_3\text{O}^+] \\ &= \frac{1}{2} \times 0,25 \\ &= 0,125 \text{ mol}\cdot\text{dm}^{-3} \quad (0,14) \end{aligned}$$

$$\begin{aligned} n(\text{H}_2\text{SO}_4)_{\text{react}} &= cV = (0,125)(0,5) = 0,0625 \text{ mol} \\ n(\text{NaOH}) &= 2n(\text{H}_2\text{SO}_4) = 2 \times 0,0625 \checkmark \\ &= 0,125 \text{ mol} \end{aligned}$$

$$n(\text{NaOH}) = \frac{m}{M} \therefore 0,125 = \frac{m}{40} \therefore m = 5 \text{ g} \checkmark$$

(9)
[16]**QUESTION 8**8.1.1 Weak acid \checkmark (1)8.1.2 $\text{pH} = -\log[\text{H}_3\text{O}^+] \checkmark$

$$4 \checkmark = -\log[\text{H}_3\text{O}^+] \therefore [\text{H}_3\text{O}^+] = 1 \times 10^{-4} \text{ mol}\cdot\text{dm}^{-3} \checkmark$$
 (3)

8.2.1 A substance that produces hydroxide ions (OH^-) in water. $\checkmark\checkmark$ (2)

8.2.2

OPTION 1

$$\begin{aligned} \frac{c_a \times V_a}{c_a \times V_b} &= \frac{n_a}{n_b} \checkmark \\ \frac{0,16 \times 25}{c_b \times 12,5} &= \frac{1}{1} \checkmark \end{aligned}$$

$$c_b = 0,32 \text{ mol}\cdot\text{dm}^{-3}$$

$$c = \frac{m}{MV}$$

$$\begin{aligned} 0,32 &= \frac{m}{56 \checkmark \times 0,25 \checkmark} \\ m &= 4,48 \text{ g} \checkmark \end{aligned}$$

OPTION 2

$$\begin{aligned} \frac{c_a \times V_a}{c_a \times V_b} &= \frac{n_a}{n_b} \checkmark \\ \frac{0,16 \times 25}{c_b \times 12,5} &= \frac{1}{1} \checkmark \end{aligned}$$

$$c_b = 0,32 \text{ mol}\cdot\text{dm}^{-3}$$

$$c = \frac{n}{V}$$

$$0,32 = \frac{n}{0,25 \checkmark} \therefore n = 0,08 \text{ mol}$$

$$\begin{aligned} n &= \frac{m}{M} \therefore 0,08 = \frac{m}{56 \checkmark} \\ \therefore m &= 4,48 \text{ g} \checkmark \end{aligned}$$

OPTION 3

$$\begin{aligned} n(\text{acid})_{\text{used}} &= cV \checkmark \\ &= (0,16)(0,025) \checkmark \\ &= 4 \times 10^{-3} \text{ mol} \\ n(\text{KOH}) &= 4 \times 10^{-3} \text{ mol} \checkmark \end{aligned}$$

$$\begin{aligned} \text{In } 12,5 \text{ cm}^3: \\ n(\text{KOH}) &= 4 \times 10^{-3} \text{ mol} \end{aligned}$$

$$\begin{aligned} \text{In } 250 \text{ cm}^3 \\ n(\text{KOH}) &= \frac{250}{12,5} \times 4 \times 10^{-3} \checkmark\checkmark \\ &= 0,08 \text{ mol} \\ m(\text{KOH}) &= nM = 0,08 \times 56 \checkmark \\ &= 4,48 \text{ g} \checkmark \end{aligned}$$

(7)

8.2.3 Greater than 7 \checkmark (1)8.2.4 $\text{CH}_3\text{COO}^-(\text{aq}) + \text{H}_2\text{O}(\ell) \checkmark \rightleftharpoons \text{CH}_3\text{COOH}(\text{aq}) + \text{OH}^-(\text{aq}) \checkmark$ Bal. \checkmark (3)

[17]

QUESTION 99.1 A substance that ionises incompletely/to a small extent. $\checkmark\checkmark$ (2)9.2 Oxalic acid \checkmark Higher K_a value \checkmark OR Carbonic acid has a lower K_a value. (2)9.3 $\text{H}_2\text{O} \checkmark$ and $(\text{COO})_2^{2-} \checkmark$ (2)

9.4

OPTION 1

$$\begin{aligned} K_w &= [\text{OH}^-][\text{H}_3\text{O}^+] \therefore 1 \times 10^{-14} = (0,1)[\text{H}_3\text{O}^+] \checkmark \\ [\text{H}_3\text{O}^+] &= 1 \times 10^{-13} \text{ mol}\cdot\text{dm}^{-3} \\ \text{pH} &= -\log[\text{H}_3\text{O}^+] \checkmark = -\log(1 \times 10^{-13}) \checkmark = 13 \checkmark \end{aligned}$$

OPTION 2

$$\begin{aligned} \text{pOH} &= -\log[\text{OH}^-] \checkmark = -\log(0,1) \checkmark = 1 \\ 14 &= \text{pOH} + \text{pH} \therefore 14 = 1 + \text{pH} \checkmark \\ \text{pH} &= 13 \checkmark \end{aligned}$$

(4)

9.5.1	<p>OPTION 1</p> $\frac{c_a \times V_a}{c_b \times V_b} = \frac{n_a}{n_b} \checkmark$ $\frac{c_a \times 14,2}{0,1 \times 25,1} = \frac{1}{2} \checkmark$ $c_a = 0,09 \text{ mol} \cdot \text{dm}^{-3} \checkmark$	<p>OPTION 2</p> $n(\text{NaOH}) = cV \checkmark = (0,1)(0,0251) \checkmark = 0,00251 \text{ mol}$ $n(\text{COOH})_2 = \frac{1}{2} (0,00251) \checkmark = 0,00126 \text{ mol}$ $c_a = \frac{n}{V} = \frac{0,00126}{0,0142} \checkmark = 0,09 \text{ mol} \cdot \text{dm}^{-3} \checkmark$	(5)
-------	-------------------------------------------------------------------------------------------------------------------------------------------------------------------------------------------------------------------------	-------------------------------------------------------------------------------------------------------------------------------------------------------------------------------------------------------------------------------------------------------------------------------------------------	-----

9.5.2	<p>C / phenolphthalein \checkmark Titration of <u>weak acid and strong base.</u> \checkmark OR The <u>endpoint will be at pH > 7</u> which is in the range of the indicator.</p>	(2) [17]
-------	----------------------------------------------------------------------------------------------------------------------------------------------------------------------------------------------------------------------------------------	-------------

QUESTION 10

10.1.1	<p>Weak \checkmark Dissociates/Ionises incompletely/partially (in water to form a low concentration of OH⁻ ions.) \checkmark</p>	(2)
--------	------------------------------------------------------------------------------------------------------------------------------------------------------------------------------------	-----

10.1.2	NH ₄ ⁺ / ammonium ion \checkmark	(1)
--------	----------------------------------------------------------	-----

10.1.3	H ₂ O/water/NH ₃ /ammonia \checkmark	(1)
--------	--------------------------------------------------------------	-----

10.2.1	Acidic pH < 7/pH = 4 \checkmark	(2)
--------	-----------------------------------	-----

10.2.2	<p>OPTION 1</p> $\text{pH} = -\log[\text{H}_3\text{O}^+] \checkmark$ $\therefore 6 \checkmark = -\log[\text{H}_3\text{O}^+] \checkmark$ $\therefore [\text{H}_3\text{O}^+] = 1 \times 10^{-6} \text{ mol} \cdot \text{dm}^{-3}$ $[\text{H}_3\text{O}^+][\text{OH}^-] = 10^{-14}$ $(1 \times 10^{-6}) [\text{OH}^-] = 10^{-14} \checkmark$ $\therefore [\text{OH}^-] = 1 \times 10^{-8} \text{ mol} \cdot \text{dm}^{-3} \checkmark$	<p>OPTION 2</p> $\text{pH} + \text{pOH} = 14 \checkmark$ $6 \checkmark + \text{pOH} = 14 \checkmark$ <p>} \checkmark Any one</p> $\text{pOH} = -\log[\text{OH}^-] \checkmark$ $\therefore 8 = -\log[\text{OH}^-] \checkmark$ $\therefore [\text{OH}^-] = 1 \times 10^{-8} \text{ mol} \cdot \text{dm}^{-3} \checkmark$	(4)
--------	--------------------------------------------------------------------------------------------------------------------------------------------------------------------------------------------------------------------------------------------------------------------------------------------------------------------------------------------------------------------------------------------------------------------------------------------	--------------------------------------------------------------------------------------------------------------------------------------------------------------------------------------------------------------------------------------------------------------------------------------------------------------------------------------------	-----

10.3	<p>OPTION 1</p> $n(\text{Na}_2\text{CO}_3) = \frac{m}{M} \checkmark = \frac{0,29}{106} \checkmark$ $\therefore n_b = 2,74 \times 10^{-3} \text{ mol} / 0,003 \text{ mol}$ $n(\text{HCl}) = 2n(\text{Na}_2\text{CO}_3) \checkmark$ $= 5,47 \times 10^{-3} \text{ mol} / 0,005 \text{ mol}$ $c(\text{HCl})_{\text{dilute}} = \frac{n}{V} = \frac{5,47 \times 10^{-3}}{0,05} \checkmark = 0,1094 \text{ mol} \cdot \text{dm}^{-3}$ $cV(\text{HCl})_{\text{dilute}} = cV(\text{HCl})_{\text{conc}}$ $\underline{0,1094 \times 500} \checkmark = \underline{(\text{HCl})_{\text{conc}} \times 5} \checkmark$ $\therefore c(\text{HCl})_{\text{conc}} = 10,94 \text{ mol} \cdot \text{dm}^{-3} \checkmark$	<p>OPTION 2</p> $n(\text{Na}_2\text{CO}_3) = \frac{m}{M} \checkmark = \frac{0,29}{106} \checkmark$ $= 2,74 \times 10^{-3} \text{ mol} / 0,003 \text{ mol}$ $n(\text{HCl}) = 2n(\text{Na}_2\text{CO}_3) \checkmark$ $= 5,47 \times 10^{-3} \text{ mol} \approx 0,005 \text{ mol}$ $5,47 \times 10^{-3} \rightarrow 50 \text{ cm}^3$ $n(\text{HCl}) \rightarrow 500 \text{ cm}^3:$ $\therefore n(\text{HCl}) = \frac{500 \times 5,47 \times 10^{-3}}{50} \checkmark$ $= 0,0547 \text{ mol}$ $c(\text{HCl})_{\text{conc}} = \frac{n}{V} = \frac{0,0547}{5 \times 10^{-3}} \checkmark$ $= 10,94 \text{ mol} \cdot \text{dm}^{-3} \checkmark$	(7) [17]
------	-------------------------------------------------------------------------------------------------------------------------------------------------------------------------------------------------------------------------------------------------------------------------------------------------------------------------------------------------------------------------------------------------------------------------------------------------------------------------------------------------------------------------------------------------------------------------------------------------------------------------------------------------------------------------------------------------------------	-------------------------------------------------------------------------------------------------------------------------------------------------------------------------------------------------------------------------------------------------------------------------------------------------------------------------------------------------------------------------------------------------------------------------------------------------------------------------------------------------------------------------------------------------------------------------------------------------------------------------------------------------	-------------

QUESTION 11

11.1.1	H ₂ O \checkmark & HSO ₄ ⁻ \checkmark	(2)
--------	----------------------------------------------------------------------------	-----

11.1.2	Strong \checkmark Completely ionised (in water). \checkmark	(2)
--------	-----------------------------------------------------------------	-----

11.2.1	<p>OPTION 1</p> $\frac{c_a \times V_a}{c_b \times V_b} = \frac{n_a}{n_b} \checkmark$ $\frac{0,15 \times 24}{c_b \times 26} = \frac{1}{2} \checkmark$ $c(\text{NaOH}) = 0,28 \text{ mol} \cdot \text{dm}^{-3} \checkmark$	<p>OPTION 2</p> $n(\text{H}_2\text{SO}_4) = cV \checkmark = (0,15)(0,024) \checkmark = 3,6 \times 10^{-3} \text{ mol}$ $n(\text{NaOH}) = 2(3,6 \times 10^{-3}) \checkmark$ $= 7,2 \times 10^{-3} \text{ mol}$ $c = \frac{n}{V} = \frac{7,2 \times 10^{-3}}{0,026} = 0,28 \text{ mol} \cdot \text{dm}^{-3} \checkmark$	(5)
--------	---------------------------------------------------------------------------------------------------------------------------------------------------------------------------------------------------------------------------------	------------------------------------------------------------------------------------------------------------------------------------------------------------------------------------------------------------------------------------------------------------------------------------------------------------------------------	-----

11.2.2	$n(\text{NaOH}) = cV = 0,02 \times 0,28 \checkmark = 0,0056 \text{ mol}$ $n(\text{H}_2\text{SO}_4) = 0,03 \times 0,15 \checkmark = 0,0045 \text{ mol}$ $n(\text{H}_2\text{SO}_4)_{\text{used}} = \frac{1}{2}n(\text{NaOH}) \checkmark = 0,0028$ $n(\text{H}_2\text{SO}_4)_{\text{excess}} = 0,0045 - 0,0028 \checkmark$ $= 0,0017 \text{ mol}$	$[\text{H}_2\text{SO}_4] = \frac{n}{V} = \frac{0,0017}{0,05} \checkmark = 0,034 \text{ mol} \cdot \text{dm}^{-3}$ $[\text{H}_3\text{O}^+] = 2[\text{H}_2\text{SO}_4] = 2 \times 0,034 \checkmark$ $= 0,068 \text{ mol} \cdot \text{dm}^{-3}$ $\text{pH} = -\log[\text{H}_3\text{O}^+] \text{ OR } -\log(0,068) \checkmark = 1,17 \checkmark$	(8) [17]
--------	------------------------------------------------------------------------------------------------------------------------------------------------------------------------------------------------------------------------------------------------------------------------------------------------------------------------------------------------	----------------------------------------------------------------------------------------------------------------------------------------------------------------------------------------------------------------------------------------------------------------------------------------------------------------------------------------------	-------------

QUESTION 12

- 12.1 Titration/Volumetric analysis ✓ (1)
- 12.2 To measure the (exact) volume of acid needed to reach endpoint/to neutralise the base. ✓ (1)
- 12.3 Acids produce hydrogen ions (H⁺)/hydronium ions (H₃O⁺) in solution/water. ✓✓ (2)
- 12.4 H₂SO₄ ionises completely. ✓ (1)
- 12.5 Blue to yellow ✓ (1)

12.6

OPTION 1	OPTION 2
$\frac{c_a V_a}{c_b V_b} = \frac{n_a}{n_b} \checkmark$ $\frac{(0,1)V_a}{(0,1)(25)} = \frac{1}{2} \checkmark \therefore V_a = 12,5 \text{ cm}^3 \checkmark$	$c_b = \frac{n}{V} \checkmark \therefore 0,1 = \frac{n}{0,025} \checkmark \therefore n_b = 2,5 \times 10^{-3} \text{ mol}$ $n_a = \frac{1}{2} n_b = \frac{1}{2} (2,5 \times 10^{-3}) \checkmark = 1,25 \times 10^{-3} \text{ mol}$ $c_a = \frac{n}{V} \therefore 0,1 = \frac{1,25 \times 10^{-3}}{V} \therefore V_a = 0,0125 \text{ dm}^3 / 12,5 \text{ cm}^3 \checkmark$

(4)

12.7

OPTION 1	OPTION 2
$n_{a(\text{excess})} = cV \checkmark$ $= (0,1)(0,005) \checkmark = 5 \times 10^{-4} \text{ mol}$ $c_a = \frac{n}{V} = \frac{5 \times 10^{-4}}{4,25 \times 10^{-2} \checkmark}$ $= 1,18 \times 10^{-2} \text{ mol} \cdot \text{dm}^{-3}$ $c(\text{H}^+) = 2c_a = 2(1,18 \times 10^{-2}) \checkmark$ $= 2,36 \times 10^{-2} \text{ mol} \cdot \text{dm}^{-3}$ $\text{pH} = -\log[\text{H}_3\text{O}^+] \checkmark = -\log(2,36 \times 10^{-2}) \checkmark$ $= 1,63 \checkmark$	$n_{a(\text{final})} = cV \checkmark$ $= (0,1)(0,0175) \checkmark = 1,75 \times 10^{-3} \text{ mol}$ $n_{a(\text{exs})} = n_{a(\text{final})} - n_{a(\text{react})}$ $= 1,75 \times 10^{-3} - 1,25 \times 10^{-3} = 5 \times 10^{-4} \text{ mol}$ $c_a = \frac{n}{V} = \frac{5 \times 10^{-4}}{4,25 \times 10^{-2} \checkmark} = 1,18 \times 10^{-2} \text{ mol} \cdot \text{dm}^{-3}$ $c(\text{H}^+) = 2c_a = 2(1,18 \times 10^{-2}) \checkmark$ $= 2,36 \times 10^{-2} \text{ mol} \cdot \text{dm}^{-3}$ $\text{pH} = -\log[\text{H}_3\text{O}^+] \checkmark = -\log(2,36 \times 10^{-2}) \checkmark = 1,63 \checkmark$

(7)
[17]

QUESTION 13

- 13.1.1 An acid is a proton donor. ✓✓ (2)
- 13.1.2 H₂O ✓ (1)
- 13.1.3 HSO₄⁻ ✓✓ (2)
- 13.2.1 Reaction of a salt with water/H₂O. ✓✓ (2)
- 13.2.2 CO₃²⁻(aq) + 2H₂O(l) ✓ ⇌ H₂CO₃(aq) + 2OH⁻(aq) ✓
- OR** CO₃²⁻(aq) + H₂O(l) ⇌ HCO₃⁻(aq) + OH⁻(aq)
- The formation of OH⁻(aq) neutralises the excess acid. ✓ (3)
- 13.3.1 pH = -log[H₃O⁺] ✓ ∴ 5 ✓ = -log[H₃O⁺] ∴ [H₃O⁺] = 1 × 10⁻⁵ mol·dm⁻³ ✓ (3)

13.3.2

OPTION 1	OPTION 2
$c(\text{H}_3\text{O}^+)_{\text{ini.}} = \frac{n}{V} \checkmark \therefore 1 \times 10^{-5} = \frac{n}{4 \times 10^9 \checkmark}$ $\therefore n_a = 4 \times 10^4 \text{ mol}$ $n(\text{H}_3\text{O}^+)_{\text{react}} = 4 \times 10^4 - 1,26 \times 10^3 \checkmark \checkmark$ $= 3,87 \times 10^4 \text{ mol}$ $n(\text{CaO}) = \frac{1}{2} n(\text{H}_3\text{O}^+) = \frac{1}{2} \times 3,87 \times 10^4 \checkmark$ $= 1,94 \times 10^4 \text{ mol}$	$c(\text{H}_3\text{O}^+)_{\text{fin}} = \frac{n}{V} \checkmark = \frac{1,26 \times 10^3}{4 \times 10^9 \checkmark}$ $= 3,15 \times 10^{-7} \text{ mol} \cdot \text{dm}^{-3}$ $c(\text{H}_3\text{O}^+)_{\text{rea}} = 1 \times 10^{-5} - 3,15 \times 10^{-7} \checkmark \checkmark$ $= 9,69 \times 10^{-6} \text{ mol} \cdot \text{dm}^{-3}$ $n(\text{H}_3\text{O}^+)_{\text{rea}} = cV = (9,69 \times 10^{-6})(4 \times 10^9)$ $= 3,87 \times 10^4 \text{ mol}$ $n(\text{CaO}) = \frac{1}{2} n(\text{H}_3\text{O}^+) = \frac{1}{2} \times 3,87 \times 10^4 \checkmark$ $= 1,94 \times 10^4 \text{ mol}$
<div style="display: flex; justify-content: center; align-items: center; gap: 20px;"> <div style="text-align: center;"> $n(\text{CaO}) = \frac{m}{M} \therefore 1,94 \times 10^4 = \frac{m}{56 \checkmark}$ $\therefore m = 1,09 \times 10^6 \text{ g} \checkmark$ </div> <div style="text-align: center;"> <p>OR</p> $1 \text{ mol} : 56 \text{ g} \checkmark$ $1,94 \times 10^4 \text{ mol} : m$ $\therefore m = 1,09 \times 10^6 \text{ g} \checkmark$ </div> </div>	

(7)
[20]

GALVANIC CELLS**QUESTION 1**

- 1.1
- Pressure: 1 atmosphere (atm) / 101,3 kPa / $1,013 \times 10^5$ Pa ✓
 - Temperature: 25 °C / 298 K ✓ (2)
- 1.2
- Platinum is inert / does not react with the H^+ ions OR acid. ✓
 - Platinum is a conductor (of electricity). ✓ (2)
- 1.3.1 Salt bridge ✓ (1)
- 1.3.2 -0,31 V ✓ (1)
- 1.3.3 $2H^+ + 2e^- \rightarrow H_2$ ✓✓ (2)
- 1.4.1 $E_{cell}^{\theta} = E_{cathode}^{\theta} - E_{anode}^{\theta}$ ✓ $\therefore 2,05$ ✓ = - 0,31 ✓ - $E_{M/M^{2+}}^{\theta}$ $\therefore E_{M/M^{2+}}^{\theta} = -2,36$ (V) ✓
 \therefore M is magnesium/ Mg. ✓ (5)
- 1.4.2 Exothermic ✓ (1)
- 1.5 The cell reaction reaches equilibrium. ✓ (1)
- [15]**

QUESTION 2

- 2.1 A substance that is being reduced. ✓✓
OR A substance that gains electrons. **OR** A substance whose oxidation number decreases. (2)
- 2.2 Ag^+ is a stronger oxidising agent ✓ than Cu^{2+} ✓ and will oxidise Cu ✓ to (blue) Cu^{2+} ions. ✓
OR Cu^{2+} is a weaker oxidising agent ✓ than Ag^+ ✓ and Cu will be oxidised ✓ to Cu^{2+} ions. ✓ (4)
- 2.3 Chemical energy to electrical energy ✓ (1)
- 2.4 A ✓ (1)
- 2.5 $E_{cell}^{\theta} = E_{cathode}^{\theta} - E_{anode}^{\theta}$ ✓ = -0,8 ✓ - 0,34 ✓ = 0,46 V ✓ (4)
- 2.6 $Cu + 2Ag^+(aq) \rightarrow Cu^{2+}(aq) + 2Ag(s)$ ✓ Balancing ✓ (3)
- 2.7 Remains the same ✓ (1)
- [16]**

QUESTION 3

- 3.1 Redox reaction ✓ (1)
- 3.2 P ✓ Negative electrode. / Mg is a stronger reducing agent/is oxidized/release electrons. ✓ (2)
- 3.3.1 (Temperature): 25 °C/298 K ✓
 (Concentration): 1 mol·dm⁻³ ✓ (2)
- 3.3.2 $Mg(s) | Mg^{2+}(aq) || Pb^{2+}(aq) | Pb(s)$ ✓ **OR** $Mg | Mg^{2+} || Pb^{2+} | Pb$ (3)
- 3.3.3 $Pb^{2+} / Pb(NO_3)_2 /$ lead(II) ions ✓ (1)
- 3.4 $E_{cell}^{\theta} = E_{cathode}^{\theta} - E_{anode}^{\theta}$ ✓ = -0,13 ✓ - (-2,36) ✓ = 2,23 V ✓ (4)
- 3.5.1 Remains the same ✓ (1)
- 3.5.2 Increases ✓ (1)
- [15]**

QUESTION 4

- 4.1 Temperature: 25 °C / 298 K ✓
 Pressure: 101,3 kPa / $1,013 \times 10^5$ Pa / 1 atm / 100 kPa ✓
 Concentration: 1 mol·dm⁻³ ✓ (3)
- 4.2.1 Cd(s) / Cadmium / Cd| Cd^{2+} / Cd^{2+} |Cd ✓ (1)
- 4.2.2 $E_{cell}^{\theta} = E_{cathode}^{\theta} - E_{anode}^{\theta}$ ✓ $\therefore 0,13$ ✓ = $E_{cathode}^{\theta} - (-0,40)$ ✓
 $E_{cathode}^{\theta} = -0,27$ V ✓ \therefore Q is Ni / nickel ✓ (5)
- 4.3.1 $Cd(s) \rightarrow Cd^{2+}(aq) + 2e^-$ ✓✓ (2)

4.3.2 Pt / Platinum ✓

(1)

4.4	Compare Q^{2+} & Cd^{2+}	Q^{2+} is reduced / Cd is oxidised and therefore <u>Q^{2+} is a stronger oxidising agent than Cd^{2+}.</u>	✓
	Compare R_2 & Cd^{2+}	R_2 is reduced / Cd is oxidised and therefore <u>R_2 is a stronger oxidising agent than Cd^{2+}.</u> ✓	✓
	Compare R_2 & Q^{2+}	<u>The cell potential of combination II is higher than that of combination I, therefore R_2 is a stronger oxidising agent than Q^{2+}.</u>	✓
	Final answer	$Cd^{2+}; Q^{2+}; R_2$ OR $Cd^{2+}; Ni^{2+}; Cl_2$	✓

(4)
[16]**QUESTION 5**

5.1 B ✓

(1)

5.2.1 $Cl_2(g) + 2e^- \rightarrow 2Cl^-(aq)$ ✓✓

(2)

5.2.2 Cl_2 / chlorine ✓

(1)

5.3 $E_{cell}^{\theta} = E_{cathode}^{\theta} - E_{anode}^{\theta}$ ✓ = 6 ✓ - (-2,36) ✓ = 3,72 V ✓

(4)

- 5.4
- The Mg electrode becomes smaller. / The mass of the Mg electrode decreases. / The Mg electrode being corroded. ✓
 - Magnesium is oxidised. / $Mg \rightarrow Mg^{2+} + 2e^-$ ✓

(2)
[10]**QUESTION 6**6.1 Electrons are transferred. ✓OR The oxidation number of Mg / H changes. OR Mg is oxidised / H^+ is reduced.

(1)

6.2 H^+ ions / HCl / $H^+(aq)$ / $HCl(aq)$ ✓

(1)

6.3 Ag is a weaker reducing agent ✓ than H_2 and will not be oxidised ✓ to Ag^+ ✓
OR H_2 is a stronger reducing agent ✓ than Ag and will be oxidised ✓ to H^+ . ✓

(3)

6.4 Electrode / Conductor of electrons in hydrogen half-cell ✓

(1)

6.5.1 Chemical energy to electrical energy ✓

(1)

6.5.2 Provides path for movement of ions./Completes the circuit./Ensures electrical neutrality in cell. ✓

(1)

6.5.3 $2H^+ + 2e^- \rightarrow H_2$ ✓✓

(2)

6.5.4 $Mg(s) | Mg^{2+}(aq) || H^+(aq) | H_2(g) | Pt$ OR $Mg(s) | Mg^{2+}(1 \text{ mol}\cdot\text{dm}^{-3}) || H^+(1 \text{ mol}\cdot\text{dm}^{-3}) | H_2(g) | Pt$

(3)

6.6 $E_{cell}^{\theta} = E_{cathode}^{\theta} - E_{anode}^{\theta}$ ✓ = 0,00 ✓ - (-2,36) ✓ = 2,36 V ✓

(4)

6.7 Increases ✓

(1)
[18]**QUESTION 7**7.1.1 $AgNO_3$ / Silver nitrate ✓

(1)

7.1.2 $Ni \rightarrow Ni^{2+} + 2e^-$ ✓✓

(2)

7.1.3 $Ni + 2Ag^+ \rightarrow Ni^{2+} + 2Ag$ ✓ Bal ✓

(3)

7.2.1 Ni ✓

Ni is a stronger reducing agent. / Ni is the anode. / Ni loses electrons. / Ni is oxidised. ✓

(2)

7.2.2 $Ni(s) | Ni^{2+}(aq) || Ag^+(aq) | Ag(s)$ OR $Ni(s) | Ni^{2+}(1 \text{ mol}\cdot\text{dm}^{-3}) || Ag^+(1 \text{ mol}\cdot\text{dm}^{-3}) | Ag(s)$

(3)

7.2.3 $E_{cell}^{\theta} = E_{cathode}^{\theta} - E_{anode}^{\theta}$ ✓ = 0,80 ✓ - (-0,27) ✓ = 1,07 V ✓

(4)

7.2.4 Increases ✓

(1)
[16]**QUESTION 8**

8.1.1 Emf ✓

(1)

8.1.2 Voltmeter/Multimeter ✓

(1)

8.1.3 Salt bridge ✓

(1)

8.1.4 Temperature: 25 °C / 298 K ✓ AND Concentration: 1 mol·dm⁻³ ✓

(2)

8.2	Marking criteria	
	Dependent and independent variables correctly identified.	✓
	Relationship between the independent and dependent variables correctly stated.	✓

Examples:Emf increases as concentration increases.

(2)

$$E_{\text{cell}}^{\theta} = E_{\text{reduction}}^{\theta} - E_{\text{oxidation}}^{\theta} \quad \checkmark \quad \therefore 1,11 \checkmark = E_{\text{X}/\text{X}^{2+}}^{\theta} - (-0,76) \checkmark \quad \therefore E_{\text{X}/\text{X}^{2+}}^{\theta} = 0,35 \text{ (V)} \checkmark$$

X = Copper / Cu ✓

(5)

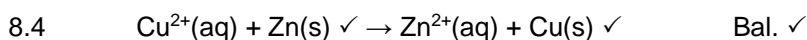

(3)

[15]**QUESTION 9**

9.1.1 Salt bridge ✓ (1)

9.1.2 Voltaic / Galvanic cell ✓ (1)

9.2.1 Decreases ✓ (1)

9.2.2 Increases ✓ (1)

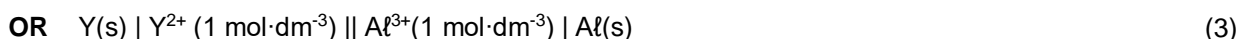
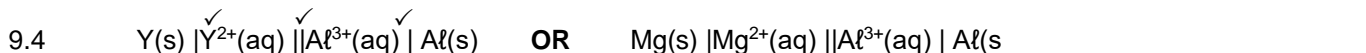

$$9.5 \quad E_{\text{cell}}^{\theta} = E_{\text{reduction}}^{\theta} - E_{\text{oxidation}}^{\theta} \quad \checkmark \quad \therefore 0,7 \checkmark = -1,66 \checkmark - E_{\text{oxidation}}^{\theta} \quad \therefore E_{\text{oxidation}}^{\theta} = -2,36 \text{ V}$$

Y is Mg ✓ (5)

[14]**QUESTION 10**

10.1.1 Voltmeter/multimeter/galvanometer ✓ (1)

10.1.2 Anode ✓ (1)



$$10.1.4 \quad E_{\text{cell}}^{\theta} = E_{\text{reduction}}^{\theta} - E_{\text{oxidation}}^{\theta} \quad \checkmark = +0,80 \checkmark - (-1,66) \checkmark = 2,46 \text{ V} \checkmark \quad (4)$$

10.2.1 Platinum/carbon ✓ (1)

10.2.2 **ANY TWO:** Concentration: 1 mol·dm⁻³ ✓; Temperature: 25 °C/298 K ✓; Pressure: 101,3 kPa/1,01 x 10⁵ Pa/1 atm (2)

10.2.3 Zinc/Zn ✓ (1)

10.2.4 PQ ✓ (1)

[14]**QUESTION 11**

11.1.1 A substance that loses/donates electrons. ✓✓ (2)

11.1.2 Platinum/Pt ✓ (1)

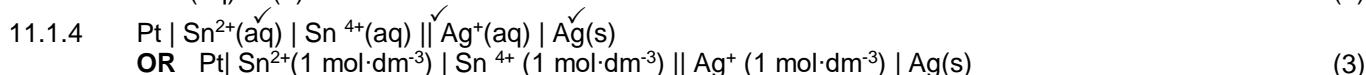
11.1.3 Sn²⁺(aq)/tin(II) ions ✓ (1)

$$11.1.5 \quad E_{\text{cell}}^{\theta} = E_{\text{reduction}}^{\theta} - E_{\text{oxidation}}^{\theta} \quad \checkmark = +0,80 \checkmark - (+0,15) \checkmark = 0,65 \text{ V} \checkmark \quad (4)$$

11.2.1 Magnesium becomes smaller./Brown solid forms. ✓ (1)

11.2.2 Cu²⁺ is a stronger oxidising agent ✓ (than Mg²⁺) and will be reduced to ✓Cu. ✓ (3)

OR Mg is a stronger reducing agent ✓ (than Cu) and will reduce Cu²⁺ to Cu. (3)

[15]**QUESTION 12**

12.1.1 Galvanic cell/Voltaic cell ✓ (1)

12.1.2 Indicates phase boundary./Interphase /phase separator ✓ (1)

- 12.1.4 $E_{\text{cell}}^{\theta} = E_{\text{reduction}}^{\theta} - E_{\text{oxidation}}^{\theta} \checkmark \therefore 0,03 \checkmark = E_{\text{X}/\text{X}^{2+}}^{\theta} - (0,77) \checkmark \therefore E_{\text{X}/\text{X}^{2+}}^{\theta} = 0,80 \text{ (V)} \checkmark$
X = Silver / Ag \checkmark (5)
- 12.2.1 Pt \checkmark (1)
- 12.2.2 Iron(III) ions \checkmark (1)
- 12.2.3 $2\text{Fe}^{3+} + \text{Cu} \checkmark \rightarrow 2\text{Fe}^{2+} + \text{Cu}^{2+} \checkmark$ Bal. \checkmark (3)

[14]**QUESTION 13**

- 13.1.1 Loss of electrons. $\checkmark\checkmark$ (2)
- 13.1.2 $\text{Fe} \rightarrow \text{Fe}^{3+} + 3\text{e}^{-} \checkmark\checkmark$ (2)
- 13.1.3 Reducing agent \checkmark (1)
- 13.1.4 Fe is a stronger reducing agent \checkmark than Cu \checkmark and (Fe) will be oxidised \checkmark (to Fe^{3+}).
OR Cu is a weaker reducing agent \checkmark than Fe \checkmark and (Cu) will not be oxidised. \checkmark (3)
- 13.1.5 Zinc/Zn \checkmark Stronger reducing agent than Fe. \checkmark (2)
- 13.2.1 $3\text{Cu}^{2+} + 2\text{Fe} \checkmark \rightarrow 3\text{Cu} + 2\text{Fe}^{3+} \checkmark$ Bal. \checkmark (3)
- 13.2.2 $E_{\text{cell}}^{\theta} = E_{\text{reduction}}^{\theta} - E_{\text{oxidation}}^{\theta} \checkmark = 0,34 \checkmark - (-0,06) \checkmark = 0,40 \text{ V} \checkmark$ (4)

[17]**ELECTROLYTIC CELLS****QUESTION 1**

- 1.1 Electrolytic \checkmark (1)
- 1.2 Q \checkmark & T \checkmark $\text{Cu}^{2+} + 2\text{e}^{-} \rightarrow \text{Cu} \checkmark\checkmark$ (4)
- 1.3.1 Cl_2 / chlorine gas \checkmark (1)
- 1.3.2 Cu^{2+} ions / copper(II) ions / CuCl_2 / copper(II) chloride \checkmark (1)
- 1.4 Cu is a stronger reducing agent \checkmark than Cl^{-} ions \checkmark and Cu will be oxidised \checkmark to Cu^{2+} .
OR Cl^{-} ions is a weaker reducing agent \checkmark than Cu \checkmark and Cu will be oxidised \checkmark to Cu^{2+} . (3)

[10]**QUESTION 2**

- 2.1 A solution that conducts electricity through the movement of ions. $\checkmark\checkmark$ (2)
- 2.2 $2\text{H}_2\text{O} + 2\text{e}^{-} \rightarrow \text{H}_2 + 2\text{OH}^{-} \checkmark\checkmark$ (2)
- 2.3 Chlorine gas / Cl_2 \checkmark (1)
- 2.4 H_2O is a stronger oxidising agent \checkmark than Na^{+} and will be reduced \checkmark to H_2 . (2)

[7]**QUESTION 3**

- 3.1 A solution that conducts electricity through the movement of ions. $\checkmark\checkmark$ (2)
- 3.2 Plastic is a non-conductor of electricity. / Graphite is a conductor. \checkmark (1)
- 3.3 $\text{Ni}^{2+}(\text{aq}) + 2\text{e}^{-} \rightarrow \text{Ni}(\text{s}) \checkmark\checkmark$ (2)
- 3.4 Ni / nickel \checkmark Ni is oxidised. \checkmark
OR: Ni loses electrons. **OR:** Ni is the anode. **OR:** Ni is the positive electrode. (2)
- 3.5 Ring \checkmark
Reduction takes place at the cathode. \checkmark **OR:** Negative electrode. (2)
- 3.6 Decreases \checkmark
 Ni^{2+} ions from the electrolyte will be reduced (to Ni). \checkmark **OR** Ni^{2+} changes to Ni. (2)

[11]**QUESTION 4**

- 4.1 The chemical process in which electrical energy is converted to chemical energy. $\checkmark\checkmark$
OR: The use of electrical energy to produce a chemical change. (2)
- 4.2 To keep the polarity of the electrodes constant. \checkmark
OR: DC provides a one way flow of electrons ensuring that the same chemical reaction occurs all the time at the same electrodes. (1)

- 4.3 $\text{Cu}^{2+}(\text{aq}) + 2\text{e}^- \rightarrow \text{Cu}(\text{s})$ ✓✓ (2)
- 4.4 Cu^{2+} is a stronger oxidising agent ✓ than Zn^{2+} . ✓ Cu^{2+} will be reduced to Cu. ✓
OR: Zn is a stronger reducing agent than Cu. Cu^{2+} will be reduced to Cu. (3)
- 4.5 $n = \frac{m}{M} \therefore 2,85 \times 10^{-2} \checkmark = \frac{m}{63,5} \checkmark \therefore m = 1,81 \text{ g AND } \% \text{purity} = \frac{1,81}{2} \checkmark = 90,49\% \checkmark$ (4)

[12]**QUESTION 5**

- 5.1 Electrolytic cell ✓ (1)
- 5.2 The substance/species which loses electrons. ✓✓ (2)
- 5.3 P ✓ (1)
- 5.4 $\text{Cu}(\text{s}) \rightarrow \text{Cu}^{2+}(\text{aq}) + 2\text{e}^-$ ✓✓ (2)
- 5.5 A ✓ (3)
- Cl^- ions move to the positive electrode / anode where they are oxidised to Cl_2 . ✓✓ (3)

[12]**QUESTION 6**

- 6.1.1 Electrolyte ✓ (1)
- 6.1.2 Electrolytic cell ✓ (1)
- 6.2 A to B ✓ (1)
- 6.3.1 B ✓ (1)
- 6.3.2 A ✓ (1)
- 6.4 Decreases ✓ (2)
- Copper (Cu) is oxidised to Cu^{2+} / Oxidation takes place at A. ✓ (2)

[7]**QUESTION 7**

- 7.1 Endothermic ✓ (1)
- 7.2 Anode ✓
 Connected to the positive terminal of the battery. ✓ (2)
- 7.3.1 Chlorine gas / Cl_2 ✓ (1)
- 7.3.2 Hydrogen gas / H_2 ✓ (1)
- 7.3.3 $2\text{H}_2\text{O}(\text{l}) + 2\text{e}^- \rightarrow \text{H}_2(\text{g}) + 2\text{OH}^-(\text{aq})$ ✓✓ (2)
- 7.4 Basic / alkaline ✓
 OH^- ions form / NaOH forms ✓ (2)

[9]**QUESTION 8**

- 8.1 Electrolytic cell ✓ (1)
- 8.2 P ✓ (1)
- 8.3.1 $\text{Au}(\text{s}) \rightarrow \text{Au}^{3+}(\text{aq}) + 3\text{e}^-$ ✓✓ (2)
- 8.3.2 +3 ✓ (1)
- 8.3.3 Electrical energy (is converted) to chemical energy ✓ (1)
- 8.3.4 Becomes smaller/thinner/eroded. ✓ (1)
- 8.4 Increase in value. ✓ **OR** Protection against rust. (1)
- 8.5 **ANY ONE:**
 Replace $\text{Au}^{3+}(\text{aq})$ / electrolyte with $\text{Ag}^+(\text{aq})$ / silver(I) solution.; Replace P/anode with Ag(s). (1)

[9]**QUESTION 9**

- 9.1 Bauxite ✓ (1)
- 9.2 Oxidation ✓ (1)
- 9.3 Reduce melting point./To lower the temperature or energy needed to melt the Al_2O_3 . ✓ (1)
- 9.4 $\text{Al}^{3+}(\text{aq}) + 3\text{e}^- \rightarrow \text{Al}(\text{s})$ ✓✓ (2)
- 9.5 $\text{C} + \text{O}_2 \checkmark \rightarrow \text{CO}_2 \checkmark$ Bal ✓ **OR:** $2\text{Al}_2\text{O}_3 + 3\text{C} \checkmark \rightarrow 4\text{Al} + 3\text{CO}_2 \checkmark$ Bal ✓ (3)

[8]

QUESTION 10

- 10.1 DC/GS ✓ (1)
- 10.2 Cathode ✓ $\text{Cu}^{2+}(\text{aq}) + 2\text{e}^- \rightarrow \text{Cu}$ ✓✓ (3)
- 10.3 Cu²⁺ ions is a stronger oxidising agent ✓ than Zn²⁺ ions ✓ and therefore Zn²⁺ ions will not be reduced (to Zn). ✓
OR Zn²⁺ ions is weaker oxidising agent than Cu²⁺ ions and therefore Zn²⁺ ions will not be reduced (to Zn). (3)
- 10.4.1 (Chlorine) gas/bubbles is/are formed. ✓ (1)
- 10.4.2 Decreases ✓ (1)
- [9]**

QUESTION 11

- 11.1 The chemical process in which electrical energy is converted to chemical energy. ✓✓
OR The use of electrical energy to produce a chemical change. (2)
- 11.2 B ✓ (1)
- 11.3 $\text{Cu}^{2+}(\text{aq}) + 2\text{e}^- \rightarrow \text{Cu}$ ✓ (2)
- 11.4 $\% \text{ purity} = \frac{m(\text{Cu})}{m(\text{Cu})_{\text{impure/onsuiwer}}} \times 100 = \frac{4,4}{5} \times 100 = 88\%$ ✓ (4)
- [9]**

QUESTION 12

- 12.1.1 Electrolyte ✓ (1)
- 12.1.2 Conduct electricity/Carry charges ✓ (1)
- 12.2 $\text{Cu}(\text{NO}_3)_2$ ✓ (1)
- 12.3 Iron rod ✓ Reduction takes place. ✓ (2)
- 12.4 $\text{Cu} \rightarrow \text{Cu}^{2+} + 2\text{e}^-$ ✓✓ (2)
- 12.5.1 Copper(II) (ions)/Cu²⁺ ✓ and silver (ions)/Ag⁺ ✓ (2)
- 12.5.2 Ag⁺/silver(I) ions is a stronger oxidising agent ✓ than Cu²⁺/Copper(II) ions and will be reduced (more readily) ✓ to form silver/Ag on the iron rod. (2)
- [11]**

QUESTION 13

- 13.1 A cell in which electrical energy is converted to chemical energy. ✓✓ **(2 or 0)**
OR A cell in which electrical energy/electricity is used to obtain a chemical change/reaction. (2)
- 13.2 Any soluble copper(II) salt e.g. $\text{CuSO}_4/\text{Cu}(\text{NO}_3)_2/\text{CuCl}_2$ ✓ (1)
- 13.3 B ✓ $\text{Cu}^{2+} + 2\text{e}^- \rightarrow \text{Cu}$ ✓✓ (3)
- 13.4 Platinum/Pt ✓ **AND** silver/Ag ✓ (2)
- [8]**

FERTILISERS**QUESTION 1**

- 1.1.1 Nitrogen / N₂ ✓ and hydrogen / H₂ ✓ (2)
- 1.1.2 $\text{NH}_3 + \text{HNO}_3 \rightarrow \text{NH}_4\text{NO}_3$ ✓ Bal. ✓ (3)

1.2

OPTION 1	OPTION 2	OPTION 3
$\% \text{ N} = \frac{3}{9} \times 36 = 12\%$ $m(\text{N}) : \frac{12}{20} \times 20 \text{ kg} = 2,4 \text{ kg}$	$m(\text{nutrients}):$ $\frac{36}{100} \times 20 = 7,2 \text{ kg}$ $\therefore m(\text{N}) = \frac{3}{9} \times 7,2 = 2,4 \text{ kg}$	$m(\text{N}):$ $\frac{3}{9} \times 20 \times \frac{36}{100} = 2,4 \text{ kg}$

(4)
[9]**QUESTION 2**

- 2.1 Contact process ✓ (1)
- 2.2.1 Vanadium pentoxide / Vanadium(V) oxide / V₂O₅ ✓ (1)
- 2.2.2 $\text{H}_2\text{S}_2\text{O}_7(\ell) + \text{H}_2\text{O}(\ell) \rightarrow 2\text{H}_2\text{SO}_4(\ell)$ ✓ Bal. ✓ (3)

- 2.3.1 $\text{H}_2\text{SO}_4 + 2\text{NH}_3 \checkmark \rightarrow (\text{NH}_4)_2\text{SO}_4 \checkmark$ Bal. \checkmark (3)
- 2.3.2 Ammonium sulphate \checkmark (1)
- 2.4.1 Total percentage of fertiliser \checkmark (1)
- 2.4.2 Mass of fertiliser in P/Massa kunsmis in P: $\frac{25}{100} \times 50 = 12,5 \text{ kg}$ } \checkmark
 Mass of fertiliser in Q/Massa kunsmis in Q: $\frac{20}{100} \times 50 = 10 \text{ kg}$ } \checkmark
 Amount of potassium in P/Massa kalium in P: $\frac{3}{10} \times 12,5 = 3,75 \text{ kg} \checkmark$
 Amount of potassium in Q/Massa kalium in Q: $\frac{4}{8} \times 10 = 5 \text{ kg} \checkmark$
 Fertiliser Q has more potassium per mass than fertiliser P. \checkmark (4)
 Kunsmis Q het meer kalium per massa as kunsmis P. [14]

QUESTION 3

- 3.1.1 $2\text{SO}_2(\text{g}) + \text{O}_2(\text{g}) \checkmark \rightarrow 2\text{SO}_3(\text{g}) \checkmark$ Bal. \checkmark (3)
- 3.1.2 Catalyst \checkmark **OR** Increase the reaction rate (1)
- 3.2 Exothermic \checkmark The temperature increases \checkmark (2)
- 3.3
 - An exothermic reaction is favoured by a decrease in temperature. \checkmark
 - The forward reaction is favoured. \checkmark
 - Higher yield (of SO_3). \checkmark (3)
- 3.4.1 $\text{H}_2\text{S}_2\text{O}_7 \checkmark$ (1)
- 3.4.2 A mist will form (which is difficult to collect). \checkmark **OR** The reaction is too exothermic. (1)
- 3.5 $\text{H}_2\text{SO}_4 + 2\text{NH}_3 \checkmark \rightarrow (\text{NH}_4)_2\text{SO}_4 \checkmark$ Bal. \checkmark (3)

[14]

QUESTION 4

- 4.1.1 Haber process \checkmark (1)
- 4.1.2 $\text{N}_2 + 3\text{H}_2 \checkmark \rightleftharpoons 2\text{NH}_3 \checkmark$ bal \checkmark (3)
- 4.1.3 Air \checkmark (1)
- 4.2.1 40% \checkmark (1)
- 4.2.2 High yield \checkmark and high rate due to higher concentration. \checkmark (2)
- 4.2.3 Low reaction rate \checkmark (1)

OPTION 1	OPTION 2
$\% \text{ N in } \text{NH}_4\text{NO}_3 = \frac{28}{80} \checkmark \times 100 = 35\%$ $m(\text{N}) \text{ in } 50 \text{ kg: } \frac{35}{100} \times 50 \checkmark = 17,5 \text{ kg} \checkmark$	$m(\text{N in } \text{NH}_4\text{NO}_3) = \frac{28}{80} \checkmark \times 50 \checkmark$ $= 17,5 \text{ kg} \checkmark$

(3)

QUESTION 5

- 5.1 Ostwald process \checkmark (1)
- 5.2 NO / nitrogen monoxide \checkmark AND water / H_2O \checkmark (2)
- 5.3 $\text{NH}_3 + \text{HNO}_3 \checkmark \rightarrow \text{NH}_4\text{NO}_3 \checkmark$ bal \checkmark (3)
- 5.4

OPTION 1	OPTION 2
$17 \text{ g } \text{NH}_3 \text{ forms } 80 \text{ g } \text{NH}_4\text{NO}_3$ $6,8 \times 10^4 \text{ kg forms } x \text{ g } \text{NH}_4\text{NO}_3$ $x = 6,8 \times 10^4 \times \frac{80}{17} = 3,2 \times 10^5 \text{ kg}$	$n(\text{NH}_3) = \frac{m}{M} = \frac{6,8 \times 10^7}{17} = 4 \times 10^6 \text{ mol}$ $n(\text{NH}_4\text{NO}_3) = n(\text{NH}_3) = 4 \times 10^6 \text{ mol}$ $m(\text{NH}_4\text{NO}_3) = nM = (4 \times 10^6)(80) = 3,2 \times 10^8 \text{ g}$

 (3)
- 5.5 To make a NPK fertiliser./To make fertilisers which contain all three primary nutrients. \checkmark (1)

[10]

QUESTION 6

- 6.1.1 Air ✓ (1)
- 6.1.2 Natural gas / methane / oil / coal ✓ (1)
- 6.1.3 Sulphur / iron pyrite / iron sulphide ✓ (1)
- 6.2.1 Haber process ✓ (1)
- 6.2.2 Ammonia ✓ (1)
- 6.2.3 H₂SO₄ ✓ (1)
- 6.2.4 SO₃ + H₂SO₄ ✓ → H₂S₂O₇ ✓ Bal. ✓ (3)
- 6.3.1 $\%N[\text{NH}_4\text{NO}_3] = \frac{28}{80} \times 100 = 35\%$
- $\%N[(\text{NH}_4)_2\text{SO}_4] = \frac{28}{132} \times 100 = 21,21\%$
- Ammonium nitrate (has the highest percentage of nitrogen). ✓ (4)
- 6.3.2 Ostwald process ✓ (1)

[14]**QUESTION 7**

- 7.1.1 Haber process ✓ (1)
- 7.1.2 Contact process / Catalytic oxidation of SO₂ ✓ (1)
- 7.1.3 Sulphur trioxide / SO₃ ✓ (1)
- 7.1.4 SO₃ + H₂SO₄ ✓ → H₂S₂O₇ ✓ Bal. ✓ (3)
- 7.1.5 H₂SO₄ ✓ + 2NH₃ ✓ → (NH₄)₂SO₄ ✓ Bal. ✓ (4)

7.2

OPTION 1

$$m(\text{fertiliser}) = \frac{36}{100} \times 20 \checkmark = 7,2 \text{ kg}$$

$$\%N = \frac{4,11}{7,2} \times 100 = 57,08\%$$

$$\%P = \frac{0,51}{7,2} \times 100 = 7,08\%$$

$$\%K = \frac{100 - \checkmark (57,08 + 7,08)}{\checkmark} = 35,84\%$$

$$57,08 : 7,08 : 35,84 \therefore 8 : 1 : 5 \checkmark$$

OPTION 2

$$m(\text{fertiliser}) = \frac{36}{100} \times 20 \checkmark = 7,2 \text{ kg}$$

$$m(K) = \underline{7,2 - \checkmark} (4,11 + 0,51) \checkmark = 2,58 \text{ kg}$$

$$4,11 : 0,51 : 2,58$$

$$8 : 1 : 5 \checkmark$$

(4)
[14]**QUESTION 8**

- 8.1.1 B ✓ & C ✓ (2)
- 8.1.2 Nitric acid/HNO₃ ✓ (1)
- 8.1.3 A ✓ (1)
- 8.1.4 2NH₃(g) + H₂SO₄ ✓ → (NH₄)₂SO₄ ✓ Bal. ✓ (3)
- 8.1.5 D ✓ (1)

8.2.1

OPTION 1

$$\%P = \frac{3}{7} \times 22\% \checkmark = 9,43\%$$

$$\therefore m(P) = \frac{9,43}{100} \times 2 \text{ kg} \checkmark = 0,19 \text{ kg} \checkmark$$

OPTION 2

$$m(P) = \frac{3}{7} \checkmark (0,44) \checkmark$$

$$= 0,19 \text{ kg} \checkmark$$

(3)

8.2.2

OPTION 1

$$m(\text{fertiliser}) = \frac{22}{100} \times 2 \checkmark = 0,44 \text{ kg}$$

$$m(\text{filler}) = 2 - 0,44 \checkmark = 1,56 \text{ kg} \checkmark$$

OPTION 2

$$\% \text{filler} = 100 - 22 \checkmark = 78\%$$

$$m(\text{filler}) = \frac{78}{100} \times 2 \checkmark = 1,56 \text{ kg} \checkmark$$

(3)
[14]

QUESTION 9

- 9.1.1 Ostwaldprocess ✓ (1)
- 9.1.2 Catalyst/Speeds up the rate of the reaction ✓ (1)
- 9.1.3 Nitrogen dioxide ✓ (1)
- 9.1.4 $3\text{NO}_2 + \text{H}_2\text{O} \rightleftharpoons 2\text{HNO}_3(\text{aq}) + \text{NO}$ ✓ Bal. ✓ (2)
- 9.1.5 Decrease pressure / Increase volume ✓ & Decrease temperature ✓ (2)
- 9.2.1 (Ratio of the) nitrogen, phosphorous and potassium in the fertiliser. ✓ (1)

9.2.2

<p>OPTION 1</p> $\%K = \frac{3}{8} \checkmark \text{ (x 25) } \checkmark$ $= 9,38\%$ $m(K) = \frac{9,38}{100} \text{ (x 50 kg) } \checkmark$ $= 4,69 \text{ kg}$	<p>OPTION 2</p> <p>m(nutrients):</p> $\frac{25}{100} \checkmark \text{ (x 50) } \checkmark = 12,5 \text{ kg}$ $\therefore m(K) = \frac{3}{8} \checkmark \text{ x } 12,5$ $= 4,69 \text{ kg}$	<p>OPTION 3</p> <p>m(K):</p> $\frac{3 \checkmark}{8} \text{ x } (50 \checkmark) \text{ (x } \frac{25 \checkmark}{100}) = 4,69 \text{ kg}$
-------------------------------------------------------------------------------------------------------------------------------------------------------------------------	-----------------------------------------------------------------------------------------------------------------------------------------------------------------------------------------------------	--------------------------------------------------------------------------------------------------------------------------------------------------

$n(K) = \frac{m}{M} = \frac{4,69 \times 10^3}{39 \checkmark} = 120 \text{ mol}$
 $m(\text{KCl}) = nM = (120)(74,5) \checkmark = 8940 \text{ g} = 8,94 \text{ kg} \checkmark$

(6)
[14]

QUESTION 10

- 10.1.1 Ammonia ✓ (1)
- 10.1.2 NO_2 ✓ (1)
- 10.1.3 Catalytic oxidation of ammonia ✓ (1)
- 10.1.4 Platinum/Pt ✓ (1)
- 10.1.5 Ostwald process ✓ (1)
- 10.1.6 Haber process ✓ (1)
- 10.1.7 $\text{NH}_3 + \text{HNO}_3 \checkmark \rightarrow \text{NH}_4\text{NO}_3 \checkmark$ Bal. ✓ (3)

10.2.1

<p>OPTION 1</p> <p>$\text{N} : \text{P} : \text{K} \Leftrightarrow 10 : 5 : 15$</p> $m(\text{fertiliser}) = \frac{30}{100} \text{ x } 15 = 4,5 \text{ kg}$ $m(\text{P}) = \frac{5}{30} \text{ x } 4,5 \checkmark \text{ OR } \left(\frac{1}{6} \text{ x } 4,5\right) = 0,75 \text{ kg} \checkmark$	<p>OPTION 2</p> <p>$\text{N} : \text{P} : \text{K}$ $10 : 5 : 15$</p> $m(\text{P}) = \frac{5}{100} \text{ x } 15 \checkmark$ $= 0,75 \text{ kg} \checkmark$
----------------------------------------------------------------------------------------------------------------------------------------------------------------------------------------------------------------------------------------------------------------------------------------------------------------------	----------------------------------------------------------------------------------------------------------------------------------------------------------------------------------------------

(2)

10.2.2

<p>OPTION 1</p> <p>$\% \text{fertiliser} = 10 + 5 + 15 = 30\%$ $\% \text{filler} = 100 - 30 = 70\% \checkmark$</p> $m(\text{filler}) = \frac{70}{100} \text{ x } 15 \checkmark = 10,5 \text{ kg} \checkmark$	<p>OPTION 2</p> <p>$10\% + 5\% + 15\% = 30\%$</p> $m = \frac{30}{100} \text{ x } 15 \checkmark \text{ OR } \left(\frac{1}{6} \text{ x } 15\right)$ $= 4,5 \text{ kg}$ $m(\text{filler}) = 15 - 4,5 \checkmark = 10,5 \text{ kg} \checkmark$
------------------------------------------------------------------------------------------------------------------------------------------------------------------------------------------------------------------------------------------------	---------------------------------------------------------------------------------------------------------------------------------------------------------------------------------------------------------------------------------------------------------------

(3)
[14]

QUESTION 11

- 11.1.1 $\text{N}_2(\text{g}) + 3\text{H}_2(\text{g}) \checkmark \rightarrow 2\text{NH}_3(\text{g}) \checkmark$ bal ✓ (3)
- 11.1.2 $(\text{NH}_4)_2\text{SO}_4 \checkmark$ (1)
- 11.1.3 Ostwald process ✓ (1)
- 11.1.4 Ammonium nitrate ✓ (1)
- 11.2.1 The ratio of nitrogen (N), phosphorous (P) and potassium (K) in a certain fertiliser. ✓ (1)
- 11.2.2 Percentage fertiliser in the bag. ✓ (1)

11.2.3

OPTION 1

$$\% K = \frac{5}{12} \times 22\% = 9,17\%$$

$$\therefore m(N) = \frac{9,17}{100} \times 10 \text{ kg} = 0,92 \text{ kg}$$

OPTION 2

m(nutrients):

$$\frac{22}{100} \times 10 = 2,2 \text{ kg}$$

$$\therefore m(K) = \frac{5}{12} \times (2,2) = 0,92 \text{ kg}$$

(4)
[12]**QUESTION 12**

12.1.1 (Catalytic) oxidation (of ammonia) ✓

(1)

12.1.2 Neutralisation/acid-base reaction ✓

(1)

12.2.1 Nitrogen/N₂ ✓

(1)

12.2.2 NO₂/nitrogen dioxide ✓

(1)

12.2.3 Nitric acid/HNO₃ ✓

(1)

12.3.1 2NH₃ + H₂SO₄ ✓ → (NH₄)₂SO₄ ✓

Bal. ✓

(3)

12.3.2 4NH₃ + 5O₂ ✓ → 4NO + 6H₂O ✓

Bal. ✓

(3)

12.4 % N = $\frac{28}{80} \times 100 = 35\%$ ✓

(3)

[14]

QUESTION 13

13.1.1 Haber process ✓

(1)

13.1.2 Ostwald process ✓

(1)

13.2.1 Ammonium nitrate/NH₄NO₃ ✓

(1)

13.2.2 Iron/iron oxide/Fe/FeO ✓

(1)

13.3 2NH₃ + H₂SO₄ ✓ → (NH₄)₂SO₄ ✓ Bal ✓

(3)

10.4

OPTION 1

NH₄NO₃: 80 g → 28 g N
 20 kg → $\frac{28}{80} \times 20$ ∴ m(N) = 7 kg ✓

Na₃PO₄: 164 g → 31 g P
 12 kg → $\frac{31}{164} \times 12$

∴ m(P) = 2,27 kg ✓

KCl: 74,5 g → 39 g K
 18 kg → $\frac{39}{74,5} \times 18$ ∴ m(K) = 9,42 kg ✓

∴ N : P : K
 7 : 2,27 : 9,42
 3 : 1 : 4 ✓

OPTION 2

$n(\text{NH}_4\text{NO}_3) = \frac{m}{M} = \frac{20\,000}{80} = 250 \text{ mol}$

$n(\text{N}) = 2n(\text{NH}_4\text{NO}_3) = 500 \text{ mol}$
 $m(\text{N}) = 500 \times 14 = 7\,000 \text{ g} = 7 \text{ kg} \checkmark$

$n(\text{Na}_3\text{PO}_4) = \frac{12\,000}{164} = 73,17 \text{ mol}$

$m(\text{P}) = 73,17 \times 31 = 2\,268 \text{ g} = 2,27 \text{ kg} \checkmark$

$n(\text{KCl}) = \frac{18\,000}{74,5} = 241,61 \text{ mol}$

$m(\text{K}) = 241,61 \times 39 = 9\,423 \text{ g} = 9,42 \text{ kg} \checkmark$

∴ N : P : K
 7 : 2,27 : 9,42
 3 : 1 : 4 ✓

(5)
[12]**BIBLIOGRAPHY**

Department of Basic Education, *National Senior Certificate Physical Sciences Question Papers*, 2014 – 2018, Pretoria